



PowerBlox 15A and 20A Synchronous Step Down COT Regulator

November 2016

Rev. 1A

GENERAL DESCRIPTION

The XR76117 and XR76121 are synchronous step-down regulators combining the controller, drivers, bootstrap diode and MOSFETs in a single package for point-of-load supplies. The XR76117 has a load current rating of 15A and the XR76121 has a load current rating of 20A. A wide 5V to 22V input voltage range allows for single supply operation from industry standard 5V, 12V and 19.6V rails.

With a proprietary emulated current mode Constant On-Time (COT) control scheme, the XR76117 and XR76121 provide extremely fast line and load transient response using ceramic output capacitors. They require no loop compensation, simplifying circuit implementation and reducing overall component count. The control loop also provides 0.1% load and 0.1% line regulation and maintains constant operating frequency. A selectable power saving mode, allows the user to operate in discontinuous mode (DCM) at light current loads thereby significantly increasing the converter efficiency.

A host of protection features, including over-current, over-temperature, over-voltage, short-circuit, open feedback detect and UVLO, help achieve safe operation under abnormal operating conditions.

The XR76117/21 are available in a RoHS-compliant, green/halogen-free space-saving QFN 5x6mm package.

EVALUATION BOARD MANUAL

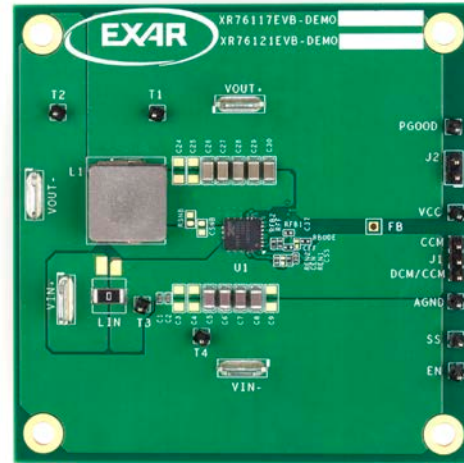

FEATURES

- 15A and 20A Step Down Regulators
 - 4.5V to 5.5V Low VIN Operation
 - 5V to 22V Wide Single Input Voltage
 - 3V to 22V operation with external 5V bias
 - $\geq 0.6V$ Adjustable Output Voltage
- Proprietary Constant On-Time Control
 - No Loop Compensation Required
 - Ceramic Output Cap. Stable operation
 - Programmable 70ns-1 μ s On-Time
 - Constant 200kHz-1MHz Freq.
 - Selectable CCM or CCM/DCM Operation
- Power-Good Flag with low impedance when power removed
- Precision Enable and Programmable Soft-start

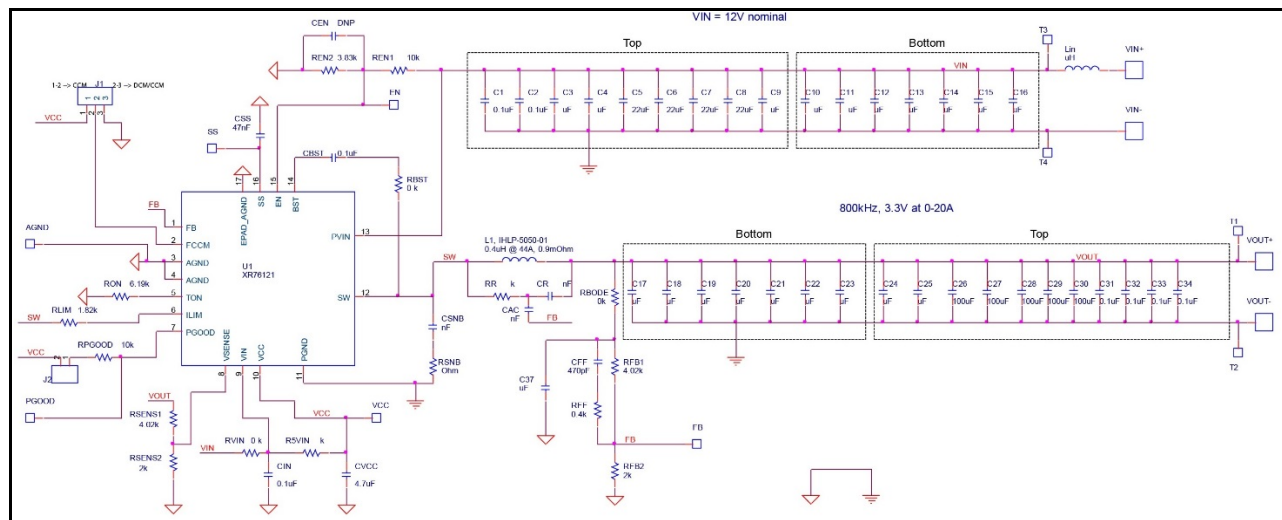

Fig. 1: XR76121 Evaluation Board Schematics



PIN ASSIGNMENT

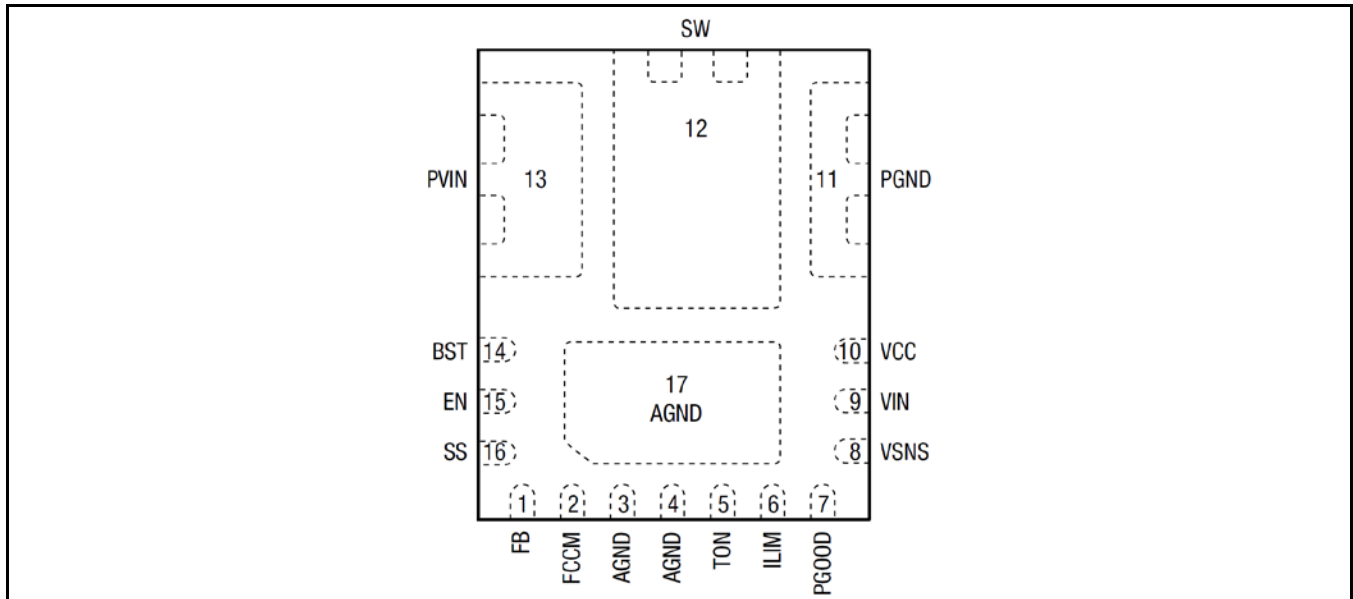

Fig. 2: XR76117/21 Pin Assignment

PIN DESCRIPTION

Name	Pin Number	Description
FB	1	Feedback input to feedback comparator.
FCCM	2	Forcing this pin logic level high forces CCM operation
AGND	3	Signal ground for control circuitry. Connect to AGND Pad with a short trace.
	4	
TON	5	Constant on-time programming pin. Connect with a resistor to AGND.
ILIM	6	Over-current protection programming. Connect with a resistor to SW.
PGOOD	7	Power-good output. Open drain to AGND. Low Z when IC unpowered.
VSNS	8	Sense pin for output OVP and open FB.
VIN	9	Supply input for the regulator's LDO. Normally connected to PVIN.
VCC	10	The output of regulator's LDO. It requires a 4.7uF VCC bypass capacitor. For operation using a 5V rail, VCC should be tied to VIN.
PGND	11	Ground of the power stage. Internally connected to source of the low-side MOSFET.
SW	12	Switch Node. Internally it connects source of the high-side MOSFET to drain of the low-side MOSFET.
PVIN	13	Input voltage for power stage. Internally connected to drain of the high-side MOSFET.
BST	14	High-side driver supply pin. Connect a 0.1uF bootstrap capacitor between BST and SW.
EN	15	Precision enable pin. Pulling this pin above 2V will enable the regulator.
SS	16	Soft-Start pin. Connect an external capacitor between SS and AGND to program the soft-start rate based on the 10uA internal source current.
AGND PAD	17	Signal ground for control circuitry.

ORDERING INFORMATION

Refer to XR76117/21 datasheet and/or www.exar.com for exact and up to date ordering information.



USING THE EVALUATION BOARD**POWERING UP**

Connect the VIN+/VIN- with short/thick leads to power supply. Use test pins T3 and T4 to monitor VIN+ and VIN- respectively. Connect VOUT+/VOUT- with short/thick leads to an electronic load. Use test pins T1 and T2 to monitor VOUT+ and VOUT- respectively. Apply 12V using the power supply. The XR76117/21 EVB should power up and regulate the output at 1.8V. Input voltage range is from 5V to 22V. Maximum rated current for XR76117/21 is 15A and 20A respectively.

JUMPER J1

If the jumper is set to CCM position the Regulator will operate in “forced CCM”. Note that, as explained in the datasheet, after power up the regulator will operate in DCM until a sufficient load is applied to transition the Regulator to CCM. Once the Regulator transitions to CCM it will continue operating in CCM regardless of load magnitude.

If the Jumper is set to DCM/CCM position the Regulator will operate in DCM at light load.

OPERATION FROM A 5V RAIL ($V_{IN}=4.5V-5.5V$)

For operation from a 5V rail it is recommended to tie output of the LDO to V_{IN} by populating R5VIN with a 0Ω resistor. This enhances the operation of the drivers at $V_{IN}<5V$. Please remember to remove R5VIN for operation at higher V_{IN} .

PROGRAMMING THE OUTPUT VOLTAGE

V_{OUT} can be programmed by changing RFB1 according to:

$$RFB1 = RFB2 \times \left(\frac{V_{OUT}}{0.6} - 1 \right)$$

Where RFB2 has a nominal value of 2kΩ.

R_{ON} must be set correspondingly, as explained in the datasheet, in order to get the desired switching frequency.



PowerBlox 15A and 20A Synchronous Step Down COT Regulator

EVALUATION BOARD SCHEMATICS

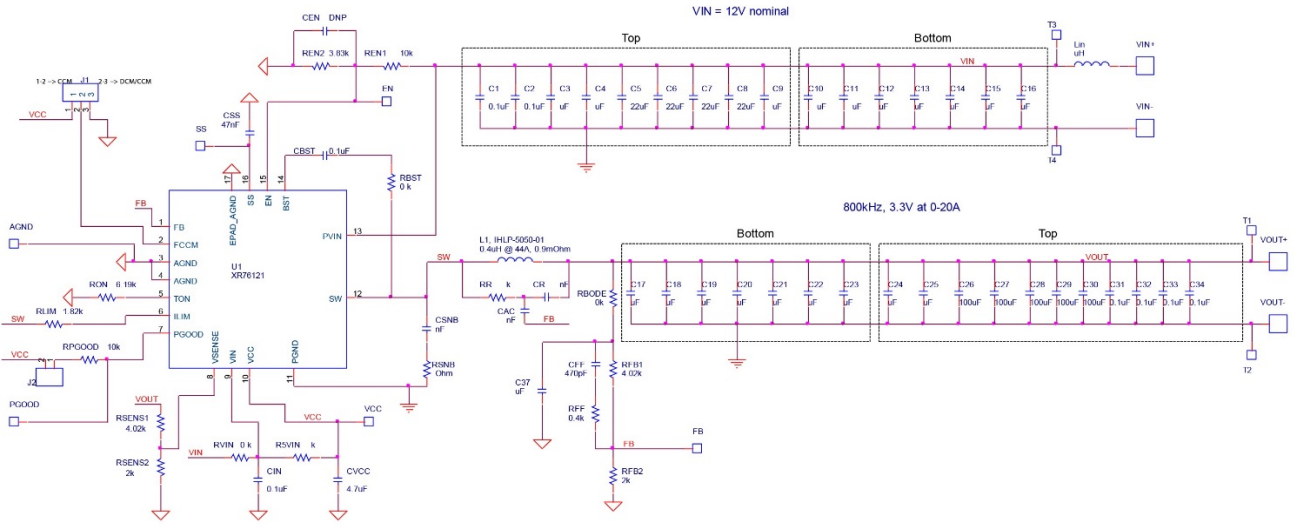

- Notes:
1. All components are 0402 unless otherwise specified
 2. C3-C9, C11-C14 are 1206/22uF/25V
 3. C17, C24-C30 are 1206/47uF/10V
 4. CSNB, RSNB, CVCC are 0603
 5. Lin is not populated, VIN+ directly connected to input capacitors

XR76121 EVB Schematics

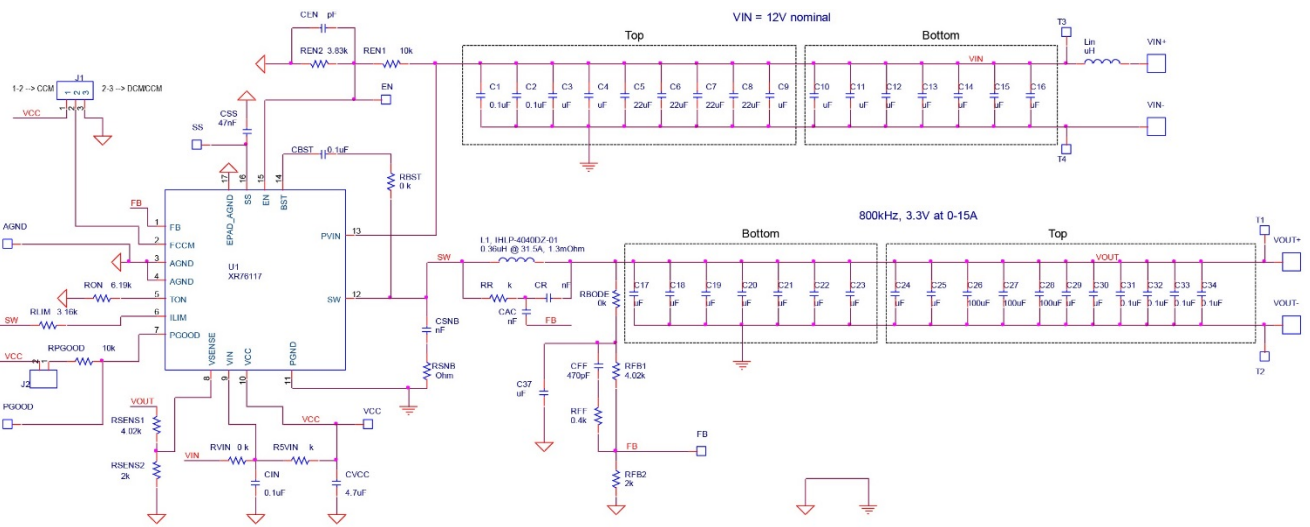

XR76117 EVB Schematics



PowerBlox 15A and 20A Synchronous Step Down COT Regulator

XR76121EVB BILL OF MATERIAL

Reference Designator	Qty.	Manufacturer	Manufacturer Part Number	Size	Component
PCB	1	Exar	146-6725-02		XR76121 Evaluation Board
U1	1	Exar	XR76121EL-F	5mmX6mm	Step-Down COT Regulator
L1	1	VISHAY/DALE	IHLP5050FDERR40M01	12.9x13.2mm	Power Inductor 0.4uH, 44A, 1mOhm
C5,C6,C7,C8	4	MURATA	GRM31CR61E226KE15L	1206	CERAMIC CAP. 22uF, 25V, X5R, 10%
C26,C27,C28,C29,C30	5	MURATA	GRM31CR60J107ME39K	1206	CERAMIC CAP. 100uF, 6.3V, X5R, 20%
CBST,CIN,C1,C2,C31-C34	8	MURATA	GRM155R71H104KE14D	0402	CERAMIC CAP. 0.1uF, 50V, X7R, 10%
CVCC	1	MURATA	GRM188R61A475KE15D	0603	CERAMIC CER, 4.7uF, 10V, X5R, 10%
CSS	1	MURATA	GRM155R71H473KE14D	0402	CERAMIC CAP, 47nF, 50V, X7R, 10%
CFF	1	MURATA	GRM155R71H471KA01D	0402	CERAMIC CAP., 470PF, 50V, X7R, 10%
RFB1,RSENS1	2	PANASONIC	ERJ-2RKF4021X	0402	Resistor 4.02K Ohm, 1/10W,1%,SMD
RFB2,RSENS2	2	PANASONIC	ERJ-2RKF2001X	0402	Resistor 2.0K Ohm, 1/10W,1%,SMD
RVIN,RBST,RBODE	3	PANASONIC	ERJ-2GE0R00X	0402	Resistor 0.00 Ohm, Jumper, 1/10W, SMD
RPGOOD, REN1	2	PANASONIC	ERJ-2RKF1002X	0402	Resistor 10.0K Ohm, 1/10W,1%,SMD
REN2	1	PANASONIC	ERJ-2RKF3831X	0402	Resistor 3.83K Ohm, 1/10W,1%,SMD
RLIM	1	PANASONIC	ERJ-2RKF1821X	0402	Resistor 1.82K Ohm, 1/10W,1%,SMD
RFF	1	PANASONIC	ERJ-2RKF4020X	0402	Resistor 402 Ohm, 1/10W,1%,SMD
RON	1	PANASONIC	ERJ-2RKF6191X	0402	Resistor 6.19K Ohm, 1/10W,1%,SMD
LIN	1	VISHAY/DALE	CRCW12100000Z0EAHP	2010	Resistor 0.00 Ohm, Jumper, 3/4W, SMD
T1-T4,VCC,PGOOD,SS,EN,AGND	9	Würth Elektronik	61300111121	2.54mm	Header 1 pin
J1	1	Würth Elektronik	61300311121	2.54mm	Header 3 pin
J2	1	Würth Elektronik	61300211121	2.54mm	Header 2 pin
VIN-, VIN+, VOUT-, VOUT+	4	Würth Elektronik	7471287		Mountin Tab WA-MTAB
J1-Jumper	1	Würth Elektronik	60900213421	2.54mm	Header Jumper

XR76117EVB BILL OF MATERIAL

Reference Designator	Qty.	Manufacturer	Manufacturer Part Number	Size	Component
PCB	1	Exar	146-6725-02		XR76117 Evaluation Board
U1	1	Exar	XR76117EL-F	5mmX6mm	Step-Down COT Regulator
L1	1	VISHAY/DALE	IHLP4040DZERR36M01	10.3x10.92mm	Power Inductor 0.36uH, 31.5A, 1.3mOhm
C5,C6,C7,C8	4	MURATA	GRM31CR61E226KE15L	1206	CERAMIC CAP. 22uF, 25V, X5R, 10%
C26,C27,C28	3	MURATA	GRM31CR60J107ME39K	1206	CERAMIC CAP. 100uF, 6.3V, X5R, 20%
CBST,CIN,C1,C2,C31-C34	8	MURATA	GRM155R71H104KE14D	0402	CERAMIC CAP. 0.1uF, 50V, X7R, 10%
CVCC	1	MURATA	GRM188R61A475KE15D	0603	CERAMIC CER, 4.7uF, 10V, X5R, 10%
CSS	1	MURATA	GRM155R71H473KE14D	0402	CERAMIC CAP, 47nF, 50V, X7R, 10%
CFF	1	MURATA	GRM155R71H471KA01D	0402	CERAMIC CAP., 470PF, 50V, X7R, 10%
RFB1,RSENS1	2	PANASONIC	ERJ-2RKF4021X	0402	Resistor 4.02K Ohm, 1/10W,1%,SMD
RFB2,RSENS2	2	PANASONIC	ERJ-2RKF2001X	0402	Resistor 2.0K Ohm, 1/10W,1%,SMD
RVIN,RBST,RBODE	3	PANASONIC	ERJ-2GE0R00X	0402	Resistor 0.00 Ohm, Jumper, 1/10W, SMD
RPGOOD, REN1	2	PANASONIC	ERJ-2RKF1002X	0402	Resistor 10.0K Ohm, 1/10W,1%,SMD
REN2	1	PANASONIC	ERJ-2RKF3831X	0402	Resistor 3.83K Ohm, 1/10W,1%,SMD
RLIM	1	PANASONIC	ERJ-2RKF3161X	0402	Resistor 3.16K Ohm, 1/10W,1%,SMD
RFF	1	PANASONIC	ERJ-2RKF4020X	0402	Resistor 402 Ohm, 1/10W,1%,SMD
RON	1	PANASONIC	ERJ-2RKF6191X	0402	Resistor 6.19K Ohm, 1/10W,1%,SMD
LIN	1	VISHAY/DALE	CRCW12100000Z0EAHP	2010	Resistor 0.00 Ohm, Jumper, 3/4W, SMD
T1-T4,VCC,PGOOD,SS,EN,AGND	9	Würth Elektronik	61300111121	2.54mm	Header 1 pin
J1	1	Würth Elektronik	61300311121	2.54mm	Header 3 pin
J2	1	Würth Elektronik	61300211121	2.54mm	Header 2 pin
VIN-, VIN+, VOUT-, VOUT+	4	Würth Elektronik	7471287		Mountin Tab WA-MTAB
J1-Jumper	1	Würth Elektronik	60900213421	2.54mm	Header Jumper



EVALUATION BOARD LAYOUT

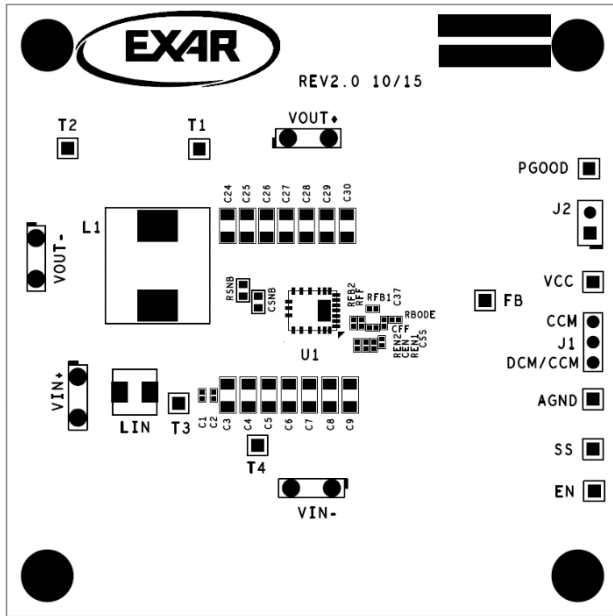

Fig. 3: Assembly Top

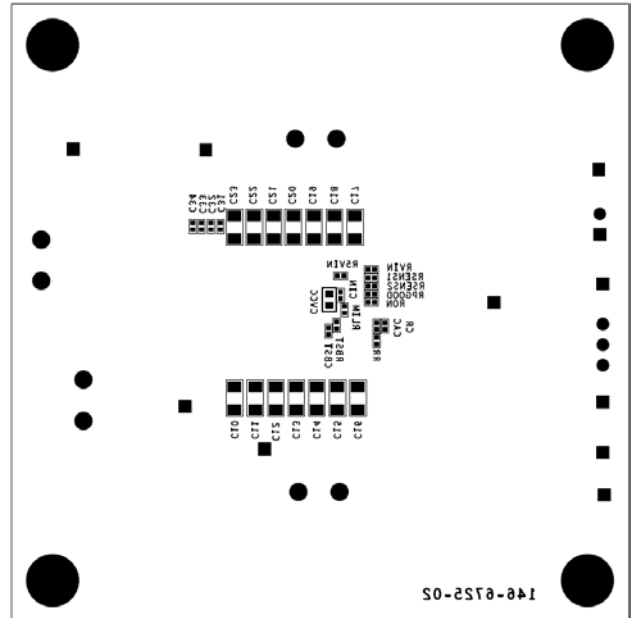

Fig. 4: Assembly Bottom

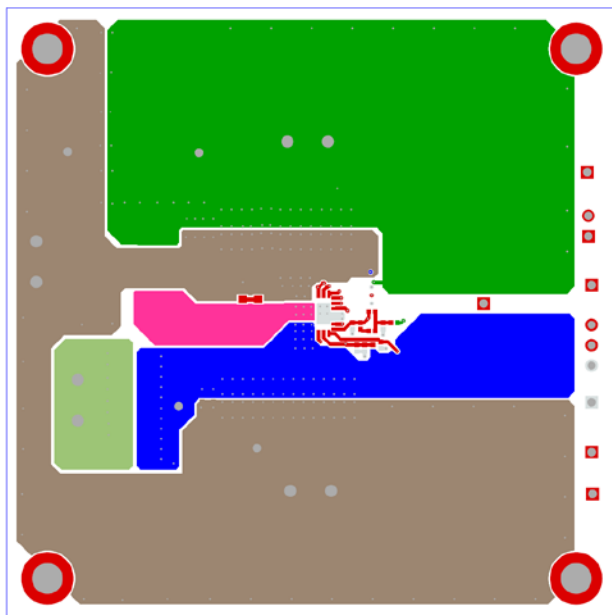

Fig. 5: Top

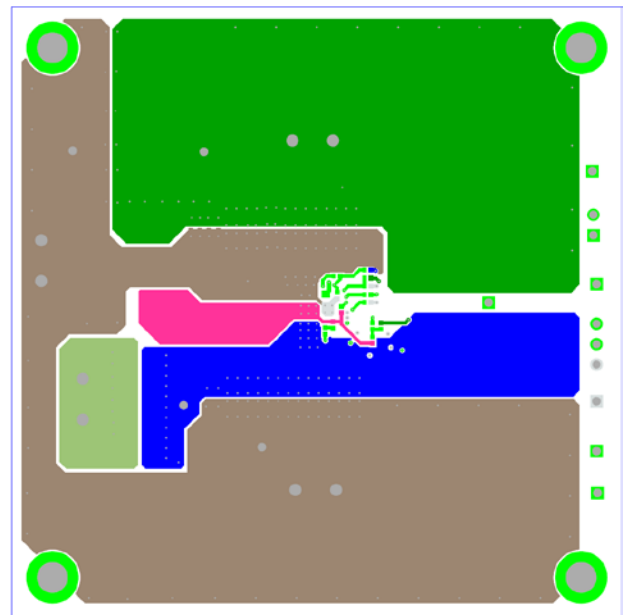

Fig. 6: Bottom

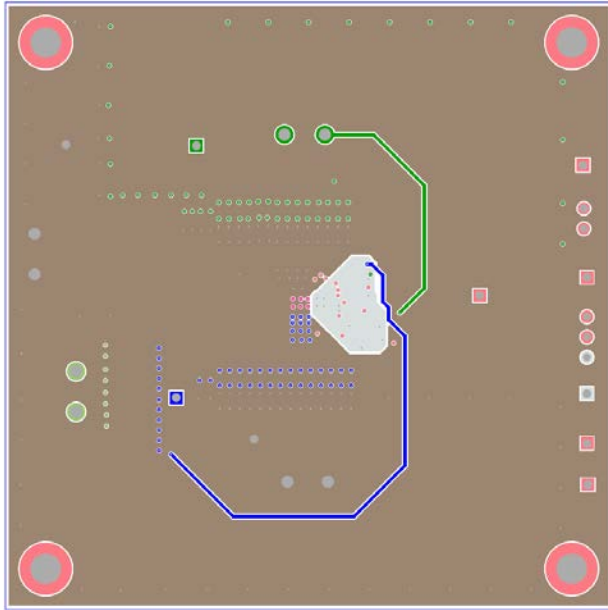

Fig. 7: Layer 2

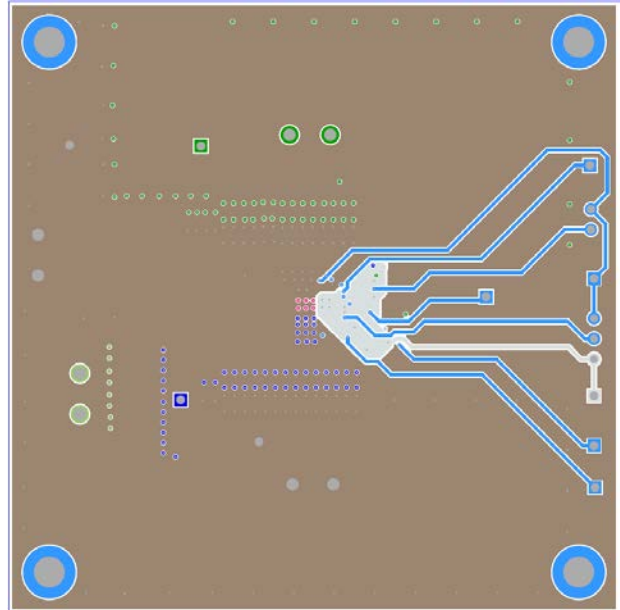

Fig. 8: Layer 3

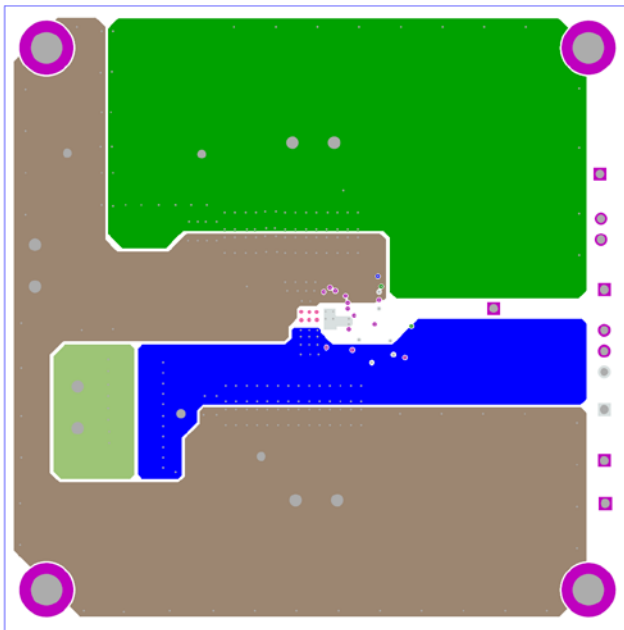

Fig. 9: Layer 4

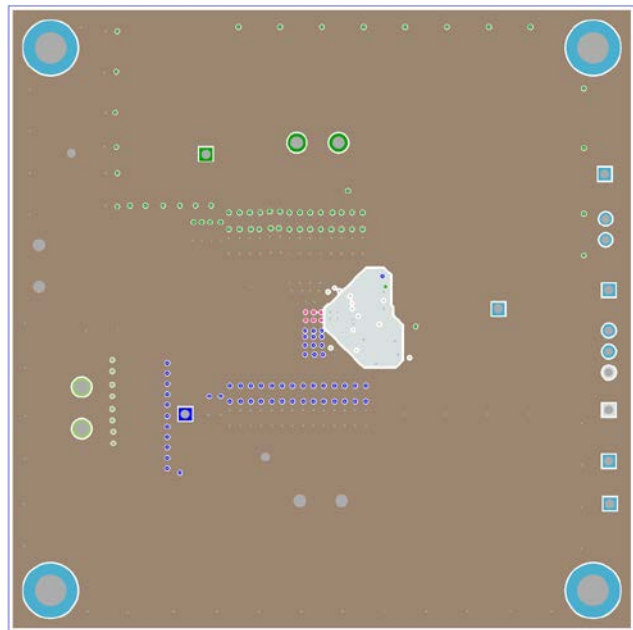

Fig. 10: Layer 5



PowerBlox 15A and 20A Synchronous Step Down COT Regulator

DOCUMENT REVISION HISTORY

Revision	Date	Description
1A	11/16	Initial release of document

BOARD REVISION HISTORY

Board Revision	Date	Description
REV 2.0	2/16	Initial release of evaluation board

FOR FURTHER ASSISTANCE

Email:

customersupport@exar.com

powertechsupport@exar.com

Exar Technical Documentation:

<http://www.exar.com/TechDoc/>



EXAR CORPORATION

HEADQUARTERS AND SALES OFFICES

48720 Kato Road

Fremont, CA 94538 – USA

Tel.: +1 (510) 668-7000

Fax: +1 (510) 668-7030

www.exar.com

NOTICE

EXAR Corporation reserves the right to make changes to the products contained in this publication in order to improve design, performance or reliability. EXAR Corporation assumes no responsibility for the use of any circuits described herein, conveys no license under any patent or other right, and makes no representation that the circuits are free of patent infringement. Charts and schedules contained herein are only for illustration purposes and may vary depending upon a user's specific application. While the information in this publication has been carefully checked; no responsibility, however, is assumed for inaccuracies.

EXAR Corporation does not recommend the use of any of its products in life support applications where the failure or malfunction of the product can reasonably be expected to cause failure of the life support system or to significantly affect its safety or effectiveness. Products are not authorized for use in such applications unless EXAR Corporation receives, in writing, assurances to its satisfaction that: (a) the risk of injury or damage has been minimized; (b) the user assumes all such risks; (c) potential liability of EXAR Corporation is adequately protected under the circumstances.

Reproduction, in part or whole, without the prior written consent of EXAR Corporation is prohibited.