



MxL86288L

Ethernet PHY

8-Port 2.5 Gigabit Ethernet PHY

MxL86288L

Data Sheet

Revision 1.2, 2026-02-24

Reference ID 621444

Legal Notice

The content of this document is furnished for informational use only, is subject to change without notice, and should not be construed as a commitment, representation, or warranty by MaxLinear, Inc. or any of its affiliates (collectively, "MaxLinear"). MaxLinear assumes no responsibility or liability for any errors, omissions, or inaccuracies that may appear in the informational content contained in this document. Complying with all applicable copyright laws is the responsibility of the user. Without limiting the rights under copyright, no part of this document may be reproduced, stored in, or introduced into a retrieval system, or transmitted in any form or by any means (electronic, mechanical, photocopying, recording, or otherwise), or for any purpose, without the express prior written permission of MaxLinear.

EXCEPT AS OTHERWISE PROVIDED EXPRESSLY IN WRITING BY MAXLINEAR, AND TO THE MAXIMUM EXTENT PERMITTED BY APPLICABLE LAW: (A) THE MAXLINEAR PRODUCTS ARE PROVIDED ON AN "AS IS" BASIS WITHOUT REPRESENTATIONS OR WARRANTIES OF ANY KIND, INCLUDING WITHOUT LIMITATION ANY IMPLIED OR STATUTORY WARRANTIES AND ANY WARRANTIES OF MERCHANTABILITY, FITNESS FOR A PARTICULAR PURPOSE, NON-INFRINGEMENT, OR TITLE; AND (B) MAXLINEAR DOES NOT WARRANT OR GUARANTEE THAT THE PRODUCTS WILL BE FREE OF ERRORS OR DEFECTS. MAXLINEAR PRODUCTS ARE NOT DESIGNED, INTENDED, AUTHORIZED, OR WARRANTED FOR USE IN ANY EMERGENCY, SECURITY, MILITARY, LIFE-SAVING, LIFE-SUSTAINING, OR OTHER CRITICAL USE CASE WHERE A FAILURE OR MALFUNCTION COULD REASONABLY BE EXPECTED TO CAUSE PERSONAL INJURY OR DEATH, OR DAMAGE TO OR LOSS OF PROPERTY. USERS ASSUME ALL RISK FOR USING THE MAXLINEAR PRODUCTS IN SUCH USE CASE. CUSTOMERS AND USERS ARE SOLELY RESPONSIBLE FOR USING THEIR OWN SKILL AND JUDGMENT TO DETERMINE WHETHER MAXLINEAR PRODUCTS ARE SUITABLE FOR THEIR INTENDED USE CASE, AND FOR CONDUCTING APPROPRIATE TESTING AND EVALUATION OF THE PRODUCTS FOR SUCH USE.

MaxLinear may have patents, patent applications, trademarks, copyrights, trade secrets, or other intellectual property rights covering subject matter in this document. Except as expressly provided in any written license agreement from MaxLinear, the furnishing of this document does not give you any license to these patents, patent applications, trademarks, copyrights, trade secrets, or other intellectual property.

MaxLinear, the MaxLinear logo, and any other MaxLinear trademarks (including but not limited to MxL, Full-Spectrum Capture, FSC, AirPHY, Puma, AnyWAN, VectorBoost, MXL WARE, and Panther) are all property of MaxLinear and/or its subsidiaries in the U.S.A. and other countries. All rights reserved.

All third-party marks and logos are trademarks™ or registered® trademarks of their respective holders/owners. Use of such marks by MaxLinear does not imply any affiliation with, sponsorship, or endorsement by or of the owners/holders of such trademarks. All references by MaxLinear to third-party trademarks are intended to constitute nominative fair use under applicable trademark laws and are used solely for purposes of identification and description.

Any URLs or third-party references provided are for informational purposes only; they do not constitute an endorsement or an approval by MaxLinear of any of the products, services, or content of any third-party corporation, organization, or individual. MaxLinear bears no responsibility or liability for the accuracy, legality, availability, or content of any external site or for that of subsequent links. Contact the external site for answers to questions regarding its content.

© 2026 MaxLinear, Inc. All rights reserved.

MaxLinear, Inc.
5966 La Place Court, Suite 100
Carlsbad, CA 92008
Tel.: +1 (760) 692-0711
Fax: +1 (760) 444-8598
www.maxlinear.com

Revision History

Current: Revision 1.2, 2026-02-24

Previous: Revision 1.1, 2025-10-27

Page	Major changes since previous revision
209	<p>Section 6.4 Vendor Specific 1 Device Registers:</p> <ul style="list-style-type: none"> Changed reset value of Packet Manager Control (Register 30.12) from “3000_H” to “3001_H”.
237	<p>Table 37 Absolute Maximum Ratings:</p> <ul style="list-style-type: none"> Corrected typo in the description of V_{DDP3V3} parameter from “VDD3V3PAD1, VDD3V3PAD2” to “VDD3V3PAD0, VDD3V3PAD1”.
Page	Major changes in Revision 1.1
260	<p>Table 61 Product and Package Naming:</p> <ul style="list-style-type: none"> Changed shipping format information and ordering part number.

Third-Party Trademark and Registered Trademark Declarations

ANSI®	“ANSI”, the ANSI logo, and numerous other identifiers containing "ANSI" are registered trademarks, service marks, and accreditation marks of the American National Standards Institute (ANSI).
Cisco®	Cisco is a registered trademark or trademark of Cisco Systems, Inc. and/or its affiliates in the United States and certain other countries. A list of other Cisco marks is available at https://www.cisco.com/c/en/us/about/legal/trademarks.html .
IEEE®	“IEEE”, the IEEE logo, and other IEEE logos and titles are registered trademarks or service marks of The Institute of Electrical and Electronics Engineers, Incorporated.
IEEE 802.1™	IEEE 802.1 is a trademark of The Institute of Electrical and Electronics Engineers, Incorporated.
IEEE 802.3™	IEEE 802.3 is a trademark of The Institute of Electrical and Electronics Engineers, Incorporated.
ITU-T®	ITU-T is a registered trademark of the ITU, a specialized agency of the United Nations.
JEDEC®	JEDEC is a registered trademark of the JEDEC Solid State Technology Association.
Macronix®	Macronix, MXIC, MXIC logo, XtraROM, NBit and Macronix NBit are trademarks of Macronix International Co., Ltd.
Microsoft®	Microsoft is a registered trademark of Microsoft Corporation in the United States and/or other countries.
NXP®	NXP is a trademark of NXP B.V.
Philips®	The PHILIPS wordmark and shield emblem are registered trademarks of Koninklijke Philips N.V.
Winbond®	Winbond is a registered trademark of Winbond Electronics Corporation.

All other trademarks or registered trademarks are the property of their respective holders/owners.

Table of Contents

	Table of Contents	5
	List of Figures	8
	List of Tables	9
	Preface	11
1	Product Overview	12
1.1	Features	13
1.2	Block Diagram	15
2	External Signals	16
2.1	Logic Symbol	16
2.2	External Signal Description	17
2.2.1	Ball Diagram	17
2.2.2	Abbreviations	19
2.2.3	Input/Output Signals	20
2.2.3.1	Ethernet Twisted Pair Interface	20
2.2.3.2	USXGMII Interface	22
2.2.3.3	MDIO Interface	23
2.2.3.4	QSPI Interface	24
2.2.3.5	I ² C Interface	26
2.2.3.6	Reset Interface	27
2.2.3.7	LED/UART/JTAG Interface	28
2.2.3.8	Miscellaneous Signals	34
2.2.3.9	Power Supply for GPHY	36
2.2.3.10	Power Supply for USXGMII	38
2.2.3.11	Power Supply for TPI (AFE)	39
2.2.3.12	Ground	40
2.2.3.13	Not Connected Signals	41
3	Functional Description	42
3.1	Power Supply, Clock, and Reset	42
3.1.1	Power Supply	42
3.1.2	Clock	42
3.1.3	Reset Generation	42
3.1.4	Power-On Sequence	42
3.1.5	Configuration by Pin Strapping	43
3.2	MDIO Slave Interface	45
3.3	Configuration via MDIO Management Interface	46
3.4	I ² C Master Interface	47
3.5	Quad Serial Peripheral Interface	48
3.5.1	Supported Flash Memory Devices	48
3.6	GPIO Mapping	50
3.7	Ethernet PHY Interface	52
3.7.1	Twisted Pair Interface	52
3.7.2	Transformerless Ethernet	52
3.7.3	Auto-Negotiation	53
3.7.4	Auto-Downspeed	53
3.7.5	Polarity Reversal Correction	53
3.7.6	Auto-Crossover Correction	53

Table of Contents

3.7.7	RJ45 Tab Up or Tab Down Configuration	54
3.7.8	Wake-on-LAN	56
3.8	Ethernet SerDes Interface	57
3.8.1	Ethernet SerDes Interface Configuration at Power On	57
3.9	LED Interface	58
3.9.1	LED	58
3.9.2	LED Configuration	58
3.9.3	LED Brightness Control	60
3.10	Smart-AZ	61
3.11	Preemption	62
3.12	Power Management	63
3.12.1	Power States	63
3.12.2	RESET PWRUP	63
3.12.3	POWER DOWN State	63
3.12.4	SCAN (ANEG) State	64
3.12.5	PING (ANEG) State	64
3.12.6	Low-Power State	64
3.12.7	NORMAL State	68
3.12.8	Low Power IDLE State - Energy-Efficient Ethernet	69
3.13	Firmware Upgrade	70
4	MDIO and MMD Register Interface Description	71
4.1	MDIO-specific Terminology	71
4.2	Register Naming and Numbering	72
4.2.1	Register Numbering	72
4.2.2	Register Naming	72
4.2.3	Examples	72
4.3	MMD Devices Present in MxL86288L	73
4.4	Responsibilities of the STA	74
4.5	MDIO Access Protocols to Read / Write Registers	75
5	MDIO Registers Detailed Description	76
5.1	Standard Management Registers	77
5.1.1	Standard Management Register Descriptions	78
5.2	PHY-specific Management Registers	100
5.2.1	PHY-specific Management Register Descriptions	101
6	MMD Registers Detailed Description	118
6.1	Standard PMAPMD Registers for MMD=0x01	119
6.1.1	PMAPMD Register Descriptions	121
6.2	Standard PCS Registers	160
6.2.1	PCS Register Descriptions	161
6.3	Standard Auto-Negotiation Registers for MMD=0x07	180
6.3.1	ANEG Register Descriptions	181
6.4	Vendor Specific 1 Device Registers	209
6.4.1	VSPEC1 Register Descriptions	210
6.5	Vendor Specific 2 Device Registers	229
6.5.1	VSPEC2 Register Descriptions	230
7	Electrical Characteristics	237
7.1	Absolute Maximum Ratings	237
7.2	Operating Range	239
7.3	Typical Power Consumption	240
7.4	Maximum Thermal Design Power	240

Table of Contents

7.5	Maximum Current	240
7.6	DC Characteristics	242
7.6.1	Digital Interfaces	242
7.6.2	Twisted Pair Interface	242
7.6.3	Built-in Temperature Sensor	243
7.7	AC Characteristics	244
7.7.1	Power Up Sequence	244
7.7.2	Input Clock	246
7.7.3	Power Supply Rail Requirements	246
7.7.3.1	V _P AC and DC Power Supply Recommendations	247
7.7.3.2	V _{PH} AC and DC Power Supply Recommendations	248
7.7.4	MDIO Slave Interface	249
7.7.5	Quad Serial Peripheral Interface (QSPI)	250
7.7.6	I ² C Interface	251
7.7.7	JTAG Interface	252
7.7.8	USXGMII Interface Characteristics	253
7.7.8.1	USXGMII Transmit Characteristics	253
7.7.8.2	USXGMII Receive Characteristics	253
7.7.9	Crystal Specification	254
7.8	External Circuitry	255
7.8.1	Twisted-Pair Common-Mode Rejection and Termination Circuitry	255
7.8.2	Transformer (Magnetics)	256
7.8.3	RJ45 Plug	257
8	Package Outline	258
9	Product Ordering Information	260
	Literature References	261
	Standards References	261
	Terminology	262

List of Figures

Figure 1	MxL86288L Block Diagram	15
Figure 2	MxL86288L External Signal Overview	16
Figure 3	Ball Diagram for PG-FCLBGA-277 (Top View).	18
Figure 4	MDIO Slave	45
Figure 5	MDIO Access Timing	46
Figure 6	Twisted-Pair Interface of MxL86288L Including Transformer and RJ45 Plug	52
Figure 7	External Circuitry for the Transformerless Ethernet Application	52
Figure 8	RJ45 Tab Up or Tab Down Configuration.	55
Figure 9	WoL Application Block Diagram	56
Figure 10	LED Connection Options to Ground or Power Supply	58
Figure 11	Connection of a Dual Color LED and Configuring Pin Strap Value	59
Figure 12	Connection of a Single Color LED and Configuring Pin Strap Value	59
Figure 13	LED Brightness Control by Controlling LED Output Enable/Disable	60
Figure 14	State Diagram for Power Down State Management.	63
Figure 15	Low Power Sequence.	65
Figure 16	EEE Low Power Idle Sequence	69
Figure 17	Input/Output Waveform for AC Tests	244
Figure 18	Timing Diagram for the Reset Sequence	245
Figure 19	DC and AC Characteristics for V_P Supply.	247
Figure 20	DC and AC Characteristics for V_{PH} Supply.	248
Figure 21	Timing Diagram for the MDIO Slave Interface	249
Figure 22	QSPI Master Interface Timing	250
Figure 23	I ² C Timing.	251
Figure 24	Test Interface Timing	252
Figure 25	Twisted Pair Common-Mode Rejection and Termination Circuitry.	255
Figure 26	Schematic of an Ethernet Transformer Device.	256
Figure 27	PG-FCLBGA-277 12 mm x 12 mm Package Outline	259

List of Tables

Table 1	Ball Diagram Color Codes	17
Table 2	Abbreviations for Pin Type	19
Table 3	Abbreviations for Buffer Type	19
Table 4	Ethernet Twisted Pair Interface Signals	20
Table 5	USXGMII Interface Signals	22
Table 6	MDIO Management Interface Signals	23
Table 7	QSPI Management Interface Signals	24
Table 8	I ² C Management Interface Signals	26
Table 9	Reset Signals	27
Table 10	LED and Debug Interface Signals	28
Table 11	Miscellaneous Signals	34
Table 12	Power Supply Pins for GPHY	36
Table 13	Power Supply Pins for USXGMII	38
Table 14	Power Supply Pins for TPI (AFE)	39
Table 15	Ground Pins	40
Table 16	Not Connected Signals	41
Table 17	Pin Names Used for Pin Strapping	43
Table 18	Pin Strapping Configuration Description	43
Table 19	MDIO Ready Timing	46
Table 20	Supported Flash Memory Devices	48
Table 21	Flash Command and Timing	49
Table 22	GPIO Mapping	50
Table 23	Supported Twisted Pair Mappings on a Cat 5 or Better Cable	54
Table 24	Programming Sequence for the Wake-on-LAN Functionality	56
Table 25	Ethernet SerDes Interface Feature List	57
Table 26	Low Power State Entry and Exit Sequence	66
Table 27	MDIO/MMD Devices Present in MxL86288L	73
Table 28	Register Access Type	76
Table 29	Registers Overview- Standard Management Registers	77
Table 30	Registers Overview- PHY-specific Management Registers	100
Table 31	Register Access Type	118
Table 32	Registers Overview- Standard PMAPMD Registers	119
Table 33	Registers Overview- Standard PCS Registers	160
Table 34	Registers Overview- Standard Auto-Negotiation Registers	180
Table 35	Registers Overview- Vendor Specific 1 Device Registers	209
Table 36	Registers Overview- Vendor Specific 2 Device Registers	229
Table 37	Absolute Maximum Ratings	237
Table 38	Operating Range	239
Table 39	Typical Power Consumption	240
Table 40	Maximum Power Consumption	240
Table 41	Maximum Current Per Rail	241
Table 42	DC Characteristics of the GPIO Interfaces (VDDP = 3.3 V)	242
Table 43	DC Characteristics of the GPIO Interfaces (VDDP = 1.8 V)	242
Table 44	Temperature Sensor Characteristics	243
Table 45	Power Supply Timings	245
Table 46	AC Characteristics of Input Clock on XTAL1 Pin	246
Table 47	AC Characteristics of the Power Supply	246
Table 48	Timing Characteristics of the MDIO Slave Interface	249
Table 49	QSPI Interface Timing Parameters	250

List of Tables

Table 50	I ² C Timing	251
Table 51	Test Interface Clock	252
Table 52	JTAG Timing	252
Table 53	Transmit Characteristics of the USXGMII	253
Table 54	Receive Characteristics of the USXGMII	253
Table 55	Specification of the Crystal	254
Table 56	Electrical Characteristics for Common-Mode Rejection and Termination Circuitry	255
Table 57	Electrical Characteristics for Supported Transformers (Magnetics)	256
Table 58	Electrical Characteristics for Supported RJ45 Plugs	257
Table 59	JEDEC Thermal Resistance Package Parameter - Compact 2-R Model Network	258
Table 60	Stress Force Package Parameter	258
Table 61	Product and Package Naming	260

Preface

This Data Sheet describes the features and system architecture of the Ethernet PHY MxL86288L, which is an 8-Port 2.5 Gigabit Ethernet PHY.

Document Conventions

In the interest of brevity, this document uses short names to represent full product names.

MxL86288L Ethernet PHY MxL86288L

Document Information

This document's identifying information is:

Document Reference (Citation) Name

MxL86288L Ethernet PHY Data Sheet Rev. 1.2

File Name

621444_MxL86288L_DS_Rev1.2.pdf

Organization of this Document

- **Chapter 1, Product Overview**
This chapter provides an overview of the MxL86288L.
- **Chapter 2, External Signals**
This chapter provides a pinout of the MxL86288L device package.
- **Chapter 3, Functional Description**
This chapter provides the functional description for the MxL86288L.
- **Chapter 4, MDIO and MMD Register Interface Description**
This chapter describes the MDIO and MMD registers available to support the MxL86288L feature set.
- **Chapter 5, MDIO Registers Detailed Description**
This chapter describes the fields and reset values of the MDIO registers.
- **Chapter 6, MMD Registers Detailed Description**
This chapter describes the fields and reset values of the MMD registers.
- **Chapter 7, Electrical Characteristics**
This chapter provides the electrical characteristics for the MxL86288L.
- **Chapter 8, Package Outline**
This chapter provides a package outline for the MxL86288L.
- **Chapter 9, Product Ordering Information**
This chapter provides the product ordering details for the MxL86288L.
- **Standards References**

1 Product Overview

The MxL86288L device is a low power multi-port Ethernet PHY transceiver integrated circuit with two 10G Ethernet SerDes interfaces. The MxL86288L has eight integrated Ethernet BASE-T PHYs which support four data rates: 2500, 1000, 100, and 10 Mbps.

On the Ethernet Twisted Pair Interface (TPI), the MxL86288L is compliant with the standards from IEEE 802.3 referenced in [2]:

- 2.5GBASE-T (IEEE 802.3 Clause 126, NBASE-T)
- 1000BASE-T (IEEE 802.3 Clause 40)
- 100BASE-TX (IEEE 802.3 Clause 25)
- 10BASE-Te (IEEE 802.3 Clause 14)

This interface supports the Energy-Efficient Ethernet (EEE) feature to reduce idle mode power consumption. Power saving at the system level is also possible with the wake-on-LAN feature. A low-EMI line driver with integrated termination facilitates the PCB design.

With reference to the Open System Interconnection (OSI) model, the MxL86288L implements eight layer 1 physical media access devices, and each is connected to a layer 2 MAC using a SerDes data interface, and an MDIO management interface.

The MxL86288L provides two Ethernet SerDes data interfaces to connect to a MAC processor with multi-port (4 x 2.5G) USXGMII interface using an MDIO slave interface for management.

The MxL86288L supports a standard MDIO management interface as defined in IEEE 802.3 Clause 22 and Clause 45 [2]. The MDIO serial interface is operable with a clock running up to 25 MHz. It allows a management entity (the external chip implementing the MAC) to access standard MDIO/MMD registers to control the MxL86288L's behavior, or to read the link status. The MxL86288L is also configurable via pin strapping.

The MxL86288L is capable of driving up to 24 LEDs (three per BASE-T port). Each LED is independently programmable to indicate the link speed and traffic activities. Several indication schemes are selectable.

External supplies of 0.8 V, 1.2 V, 1.8 V, and 3.3 V are required to power the MxL86288L device.

The MxL86288L uses a ball grid array package (type BGA 18 x18 matrix, size 12 mm x 12 mm).

1.1 Features

This section provides an overview of the features supported by the MxL86288L.

Communication Interfaces

- The eight Ethernet BASE-T interfaces support:
 - Ethernet modes and standards
2.5GBASE-T (IEEE 802.3, NBASE-T), 1000BASE-T (IEEE 802.3), 100BASE-TX (IEEE 802.3), and 10BASE-T_e (IEEE 802.3)
 - Ethernet twisted pair copper cable of category Cat5 or higher
 - Low EMI voltage mode line driver with integrated termination resistors
 - Transformerless Ethernet for backplane applications
 - Auto-Negotiation (ANEG) with extended next page support
 - Auto-MDIX and polarity correction
 - Auto-Downspeed (ADS)
 - 100BASE-TX EEE, 1000BASE-T EEE, 2.5GBASE-T EEE, and power down mode
 - Cable diagnostics: cable open/short detection and cable length estimation
 - Wake-on-LAN (WoL)
 - Jumbo frames of up to 10 kB
- Two Ethernet SerDes interfaces, where each interface supports:
 - 10G-USXGMII
 - The PHY complies with all of the required features specified in the Cisco USXGMII Multiport Copper PHY Specification [5] and Cisco USXGMII Single-port Copper PHY Specification [6]
 - Back channel equalization, auto-negotiation, Forward Error Correction (FEC)
 - Clock and Data Recovery (CDR), no clock forwarding required
 - Clause 37 auto-negotiation
 - Packet Control Header (PCH) over Preamble
- The management interface supports the communication between the Station Manager (STA, per IEEE 802.3) and the MxL86288L using:
 - A Management Data Input/Output (MDIO) slave interface providing access to the standard registers in the MMD
 - An MDIO interface clock of up to 25 MHz
 - 3 MDIO message frame types as described in IEEE 802.3: Clause 22, Clause 22 Extended, and Clause 45 [2]
- The Quad SPI master interface connecting to serial external Quad-SPI flash memory supports:
 - Programmable interface clock: maximum 101 MHz
 - Internal firmware code access from external Quad-SPI flash memory
 - Write access to the Quad-SPI flash memory
 - Different Quad-SPI flash memory sizes up to 512 MB
 - Secure firmware upgrade of the flash memory
- One instance of the I²C master interface controlling external devices supports these speed modes:
 - Standard mode (<100 Kbps)
 - Fast mode (<400 Kbps)
 - Fast mode plus (<1000 Kbps)
 - High speed mode (<3.4 Mbps)
- The JTAG interface supports:
 - Boundary scan
 - Test and debug interface
 - Shared pins with GPIO functions
- The LED interface supports:
 - Programmable LED
 - Up to three LEDs per BASE-T port

- Single and dual color LEDs
- Connection of LED to ground or 3.3 V
- Several LED indication schemes (link/activity, duplex/collision, and link speed)
- Configuration of LED indication via MDIO registers
- Control of LED brightness via software driver API
- Alternative configuration of LED pins as GPIO for custom indication
- Supports two external interrupts:
 - Configurable as output to an external controller
 - Configurable as input from external device(s)
 - Configurable edge, level, and polarity

Flash and Flashless Mode

- In flash mode, an external QSPI memory device is required to store the firmware
- In flashless mode, the firmware is downloaded from a host MAC SoC via the MDIO interface:
 - Broadcast firmware download support
 - Secure firmware download

Clocking and Timing Features

- The input reference clock options are:
 - 25 MHz crystal operation
 - 25 MHz direct from an external oscillator
 - An external CML/LVPECL reference clock operating at 50 MHz or 156.25 MHz

Preemption

- Recognize preemption packet types defined in IEEE 802.3br.
- Forwarding of preemption packets
- PCH support of preemption packets

Other Features

- Temperature Sensor (warning, interrupt, reset, and auto-downspeed)

Power Supply

- 3.3 V, 1.8 V, 1.2 V, and 0.8 V external power sources

1.2 Block Diagram

Figure 1 shows the block diagram of the MxL86288L. The main interfaces are:

- Data interface to SoC/MAC processor, using USXGMII
- Slave control interface driven by a SoC/MAC processor, using MDIO slave
- Master control interface using I²C master
- Interrupt signal MDINT allowing the MxL86288L to notify the SoC/MAC processor about a change of status
- LED control
- Twisted pair interfaces (TPI)
- Master Quad Serial Peripheral Interface (QSPI) interface

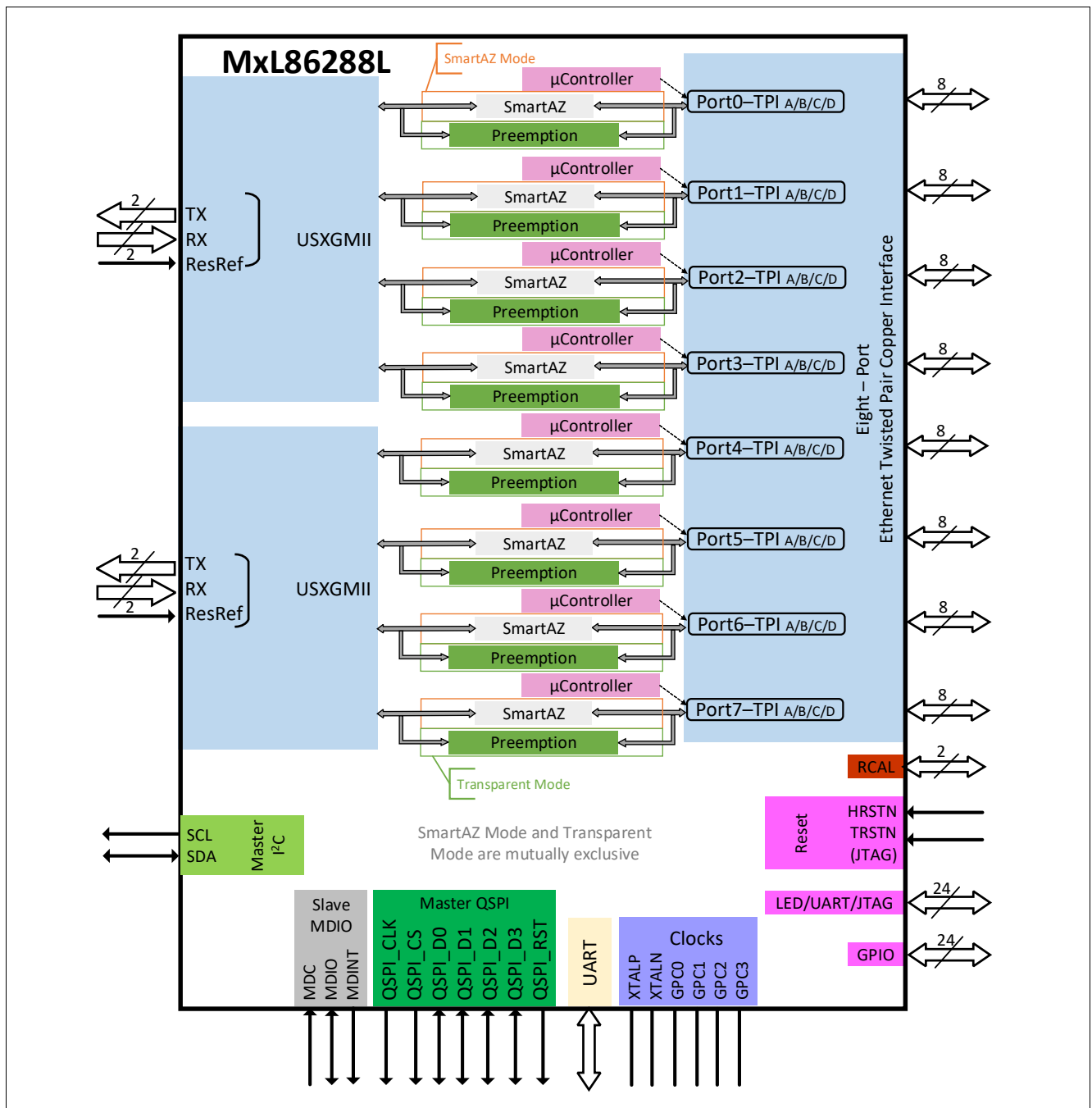

Figure 1 MxL86288L Block Diagram

2 External Signals

This chapter describes the signal mapping to the package.

2.1 Logic Symbol

Figure 2 gives an overview of the device's external interfaces.

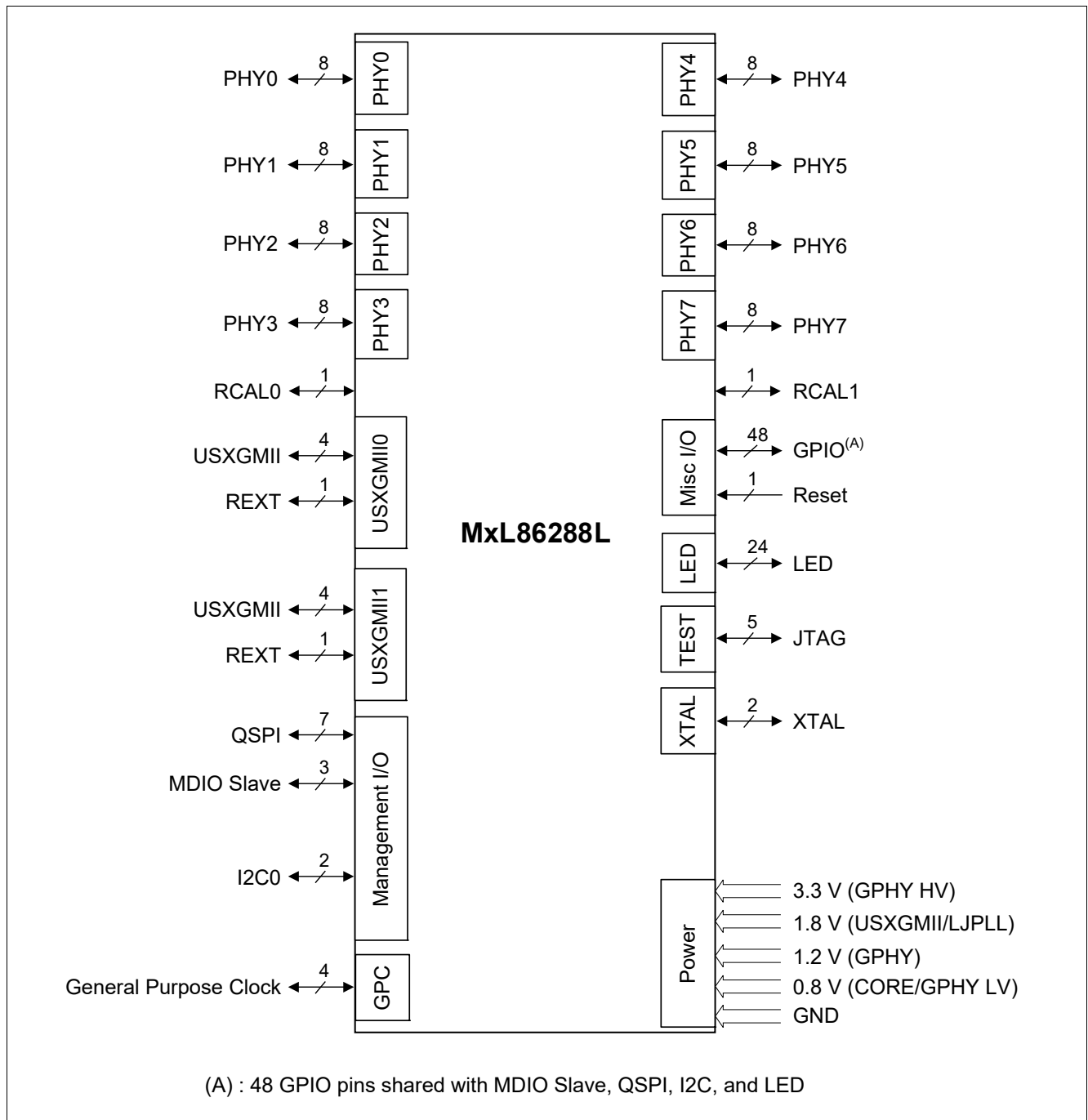

Figure 2 MxL86288L External Signal Overview

2.2 External Signal Description

This section provides the ball diagram, abbreviations for pin types and buffer types, and the table of input and output signals.

2.2.1 Ball Diagram

Figure 3 shows the ball diagram. **Table 1** lists the ball diagram color codes.

Table 1 Ball Diagram Color Codes

Color	Description
White	Unpopulated Balls
Red	Power
Light Red	USXGMII Power
Orange	MDIO, I ² C Signals
Grey	Ground
Blue	TPI-related Signals
Pink	QSPI, Reset Signals
Yellow	USXGMI Signals
Light Green	Clock, GPIO Signals
Light Blue	LED, JTAG Signals
White	NC

	1	2	3	4	5	6	7	8	9	10	11	12	13	14	15	16	17	18	
A	TPVS SA_0	TPBP _3	TPAP _3	TPDP _2	TPCP _2	TPBP _2	TPAP _2	TPDP _1	TPCP _1	TPBP _1	TPAP _1	TPDP _0	TPCP _0	TPBP _0	TPAP _0	TPVS SA_0	URXM _0	UVSS	A
B	TPCP _3	TPBN _3	TPAN _3	TPDN _2	TPCN _2	TPBN _2	TPAN _2	TPDN _1	TPCN _1	TPBN _1	TPAN _1	TPDN _0	TPCN _0	TPBN _0	TPAN _0	URES REF_0	URXP _0	UVSS	B
C	TPCN _3	TPDN _3	TPDP _3	TPVS SA_0	TPVS SA_0	VDDA 3V3_3	TPVS SA_0	VDDA 3V3_2	TPVS SA_0	VDDA 3V3_1	TPVS SA_0	VDDA 3V3_0	TPVS SA_0	TPVS SA_0	VA0V 8_0	UVSS	UTXM _0	UTXP _0	C
D		TPVS SA_0	VSSD	VSSD	GPIO1	TPVS SA_0	TPVS SA_0	VDDA 1V8_0	VDDA 1V8_0	TPVS SA_0	RCAL _0	TPVS SA_0	TPVS SA_0	VA0V 8_0	VPHA 1V8_0	VSS_XO	VSS_XO	UVSS	D
E	PHYL ED1_0	PHYL ED2_0	PHYL ED3_0	HRSTN											VSSD	XTAL2	XTAL1		E
F		PHYL ED1_1	PHYL ED2_1	VSSD		TPVS SA_0	VDDA 0V8_0	TPVS SA_0	VDDA 0V8_0	VDDA 1V2C DB0	TPVS SA_0	VDDA 0V8_0	TPVS SA_0	VDD3 V3PA D1	VSS_XO	I2C_S DA_0	I2C_S CL_0		F
G	PHYL ED3_1	PHYL ED1_2	PHYL ED3_2	VDD3 V3PA D0		VDDD 0V8_COR	VSSD	VDDD 0V8_COR	VSSD	VDDD 1V2C DB0	VSSD	VDDD 0V8_COR	VDDD 0V8_COR	VDD3 V3PA D1	MDINT	NC	NC		G
H		PHYL ED2_2	PHYL ED3_3	VDD3 V3PA D0		VDDD 0V8_COR	VSSD	VDDD 0V8_COR	VSSD	VDDD 0V8_COR	VDDD 0V8R EF	VSSD	VSS_XO	VSSD	VSSD	GPC3			H
J	PHYL ED1_3	PHYL ED2_3	PHYL ED1_4	VSSD		VSSD	VDDD 0V8_COR	VSSD	VDDD 0V8_COR	VSSD	VDDD 0V8R EF	VCC1 V8_0 TP	VDDA 1V8P ORXO	VDDP _PAD	GPC2	GPC0	GPC1		J
K	VSSD	PHYL ED2_4	VSSD	GPIO3		VSSD	VDDD 0V8_COR	VSSD	VDDD 0V8_COR	VSSD	VDDD 0V8P OST	VSSD	VDDA 1V8_PVT	VSSD	MDIO_S	MDC_S			K
L		PHYL ED3_5	PHYL ED3_4	VDD3 V3PA D0		VDDD 0V8_COR	VSSD	VDDD 0V8_COR	VSSD	VDDD 0V8_COR	VSSD	VSSD	VDDA 1V8_PVT	QSPI _RST	GPIO0	GPIO8	GPIO7		L
M	PHYL ED1_5	PHYL ED1_6	PHYL ED2_5	VDD3 V3PA D0		VDDD 0V8_COR	VSSD	VDDD 0V8_COR	VSSD	VDDA 1V2C DB1	VSSD	VDDD 0V8_COR	VDDD 0V8_COR	QSPI _CLK	GPIO 19	GPIO 18			M
N		PHYL ED3_6	PHYL ED2_6	VSSD		TPVS SA_1	VDDA 0V8_1	TPVS SA_1	VDDA 0V8_1	VDDA 1V2C DB1	TPVS SA_1	VDDA 0V8_1	TPVS SA_1	QSPI _CS	VSSD	NC	NC		N
P	PHYL ED1_7	PHYL ED2_7	PHYL ED3_7	GPIO2										VDD3 V3PA D1	QSPI _D2	QSPI _D3			P
R		TPVS SA_1	TRSTN	VSSD	VSSD	TPVS SA_1	TPVS SA_1	VDDA 1V8_1	VDDA 1V8_1	TPVS SA_1	RCAL _1	TPVS SA_1	TPVS SA_1	VA0V 8_1	VPHA 1V8_1	QSPI _D1	QSPI _D0	UVSS	R
T	TPBP _4	TPAP _4	TPAN _4	TPVS SA_1	TPVS SA_1	VDDA 3V3_4	TPVS SA_1	VDDA 3V3_5	TPVS SA_1	VDDA 3V3_6	TPVS SA_1	VDDA 3V3_7	TPVS SA_1	TPVS SA_1	VA0V 8_1	UVSS	UTXM _1	UTXP _1	T
U	TPBN _4	TPCP _4	TPDP _4	TPAP _5	TPBP _5	TPCP _5	TPDP _5	TPAP _6	TPBP _6	TPCP _6	TPDP _6	TPAP _7	TPBP _7	TPCP _7	TPDP _7	URES REF_1	URXP _1	UVSS	U
V	TPVS SA_1	TPCN _4	TPDN _4	TPAN _5	TPBN _5	TPCN _5	TPDN _5	TPAN _6	TPBN _6	TPCN _6	TPDN _6	TPAN _7	TPBN _7	TPCN _7	TPDN _7	TPVS SA_1	URXM _1	UVSS	V

Figure 3 Ball Diagram for PG-FCLBGA-277 (Top View)

2.2.2 Abbreviations

Table 2 and **Table 3** summarize the abbreviations used in the signal tables.

Table 2 Abbreviations for Pin Type

Abbreviations	Description
I	Input-only, digital levels
O	Output-only, digital levels
I/O	Bidirectional input/output signal, digital levels
Prg	Bidirectional pin, programmable to operate either as input or output, digital levels
AI	Input-only, analog levels
AO	Output-only, analog levels
AI/AO	Bidirectional, analog levels
PWR	Power
GND	Ground

Table 3 Abbreviations for Buffer Type

Abbreviations	Description
A	Analog characteristics, see the AC/DC specification for more information.
Prg	Programmable (open-drain/push-pull, pull-up/pull-down characteristic are programmable)
PU	Pull up (internal, weak)

2.2.3 Input/Output Signals

Table 4 to Table 16 provide a detailed description of all the pins.

2.2.3.1 Ethernet Twisted Pair Interface

Unused TPI signals must be unconnected.

Table 4 Ethernet Twisted Pair Interface Signals

Ball No.	Name	Pin Type	Buffer Type	Function
Ethernet Port Twisted Pair Interface				
A15	TPAP_0	AI/AO	A	Port 0 Transmit/Receive Positive/Negative
B15	TPAN_0	AI/AO	A	
A14	TPBP_0	AI/AO	A	
B14	TPBN_0	AI/AO	A	
A13	TPCP_0	AI/AO	A	
B13	TPCN_0	AI/AO	A	
A12	TPDP_0	AI/AO	A	
B12	TPDN_0	AI/AO	A	
A11	TPAP_1	AI/AO	A	Port 1 Transmit/Receive Positive/Negative
B11	TPAN_1	AI/AO	A	
A10	TPBP_1	AI/AO	A	
B10	TPBN_1	AI/AO	A	
A9	TPCP_1	AI/AO	A	
B9	TPCN_1	AI/AO	A	
A8	TPDP_1	AI/AO	A	
B8	TPDN_1	AI/AO	A	
A7	TPAP_2	AI/AO	A	Port 2 Transmit/Receive Positive/Negative
B7	TPAN_2	AI/AO	A	
A6	TPBP_2	AI/AO	A	
B6	TPBN_2	AI/AO	A	
A5	TPCP_2	AI/AO	A	
B5	TPCN_2	AI/AO	A	
A4	TPDP_2	AI/AO	A	
B4	TPDN_2	AI/AO	A	
A3	TPAP_3	AI/AO	A	Port 3 Transmit/Receive Positive/Negative
B3	TPAN_3	AI/AO	A	
A2	TPBP_3	AI/AO	A	
B2	TPBN_3	AI/AO	A	
B1	TPCP_3	AI/AO	A	
C1	TPCN_3	AI/AO	A	
C3	TPDP_3	AI/AO	A	

Table 4 Ethernet Twisted Pair Interface Signals (cont'd)

Ball No.	Name	Pin Type	Buffer Type	Function
C2	TPDN_3	AI/AO	A	
T2	TPAP_4	AI/AO	A	Port 4 Transmit/Receive Positive/Negative
T3	TPAN_4	AI/AO	A	
T1	TPBP_4	AI/AO	A	
U1	TPBN_4	AI/AO	A	
U2	TPCP_4	AI/AO	A	
V2	TPCN_4	AI/AO	A	
U3	TPDP_4	AI/AO	A	
V3	TPDN_4	AI/AO	A	
U4	TPAP_5	AI/AO	A	Port 5 Transmit/Receive Positive/Negative
V4	TPAN_5	AI/AO	A	
U5	TPBP_5	AI/AO	A	
V5	TPBN_5	AI/AO	A	
U6	TPCP_5	AI/AO	A	
V6	TPCN_5	AI/AO	A	
U7	TPDP_5	AI/AO	A	
V7	TPDN_5	AI/AO	A	
U8	TPAP_6	AI/AO	A	Port 6 Transmit/Receive Positive/Negative
V8	TPAN_6	AI/AO	A	
U9	TPBP_6	AI/AO	A	
V9	TPBN_6	AI/AO	A	
U10	TPCP_6	AI/AO	A	
V10	TPCN_6	AI/AO	A	
U11	TPDP_6	AI/AO	A	
V11	TPDN_6	AI/AO	A	
U12	TPAP_7	AI/AO	A	Port 7 Transmit/Receive Positive/Negative
V12	TPAN_7	AI/AO	A	
U13	TPBP_7	AI/AO	A	
V13	TPBN_7	AI/AO	A	
U14	TPCP_7	AI/AO	A	
V14	TPCN_7	AI/AO	A	
U15	TPDP_7	AI/AO	A	
V15	TPDN_7	AI/AO	A	
Ethernet Port Test Point				
D11	RCAL_0	AI/AO	A	Test Point for GPHY Ethernet Ports 0 to 3 Test point, do not connect.
R11	RCAL_1	AI/AO	A	Test Point for GPHY Ethernet Ports 4 to 7 Test point, do not connect.

2.2.3.2 USXGMII Interface
Table 5 USXGMII Interface Signals

Ball No.	Name	Pin Type	Buffer Type	Function
B17	URXP_0	AI	A	Differential USXGMII 0 Data Input Pair These are the negative and positive signals of the differential input pair of the USXGMII SerDes interface. Due to the integrated CDR, no external transmission peer source-synchronous clock is required for USXGMII. These pins must be AC-coupled.
A17	URXM_0	AI	A	
C18	UTXP_0	AO	A	Differential USXGMII 0 Data Output Pair These are the negative and positive signals of the differential output pair of the USXGMII SerDes interface. Due to the integrated CDR, no external transmission peer source-synchronous clock is required for USXGMII. These pins must be AC-coupled.
C17	UTXM_0	AO	A	
B16	URESREF_0	AI/AO	A	External USXGMII Tuning Resistor 0 Attach a 200 Ω ($\pm 1\%$) resistor-to-ground on the board.
U17	URXP_1	AI	A	Differential USXGMII 1 Data Input Pair These are the negative and positive signals of of the differential input pair of the USXGMII SerDes interface. Due to the integrated CDR, no external transmission peer source-synchronous clock is required for USXGMII. These pins must be AC-coupled.
V17	URXM_1	AI	A	
T18	UTXP_1	AO	A	Differential USXGMII 1 Data Output Pair These are the negative and positive signals of the differential output pair of the USXGMII SerDes interface. Due to the integrated CDR, no external transmission peer source-synchronous clock is required for USXGMII. These pins must be AC-coupled.
T17	UTXM_1	AO	A	
U16	URESREF_1	AI/AO	A	External USXGMII Tuning Resistor 1 Attach a 200 Ω ($\pm 1\%$) resistor-to-ground on the board.

2.2.3.3 MDIO Interface

Table 6 MDIO Management Interface Signals

Ball No.	Name	Pin Type	Buffer Type	Function
MDIO Slave Interface				
G16	MDINT	O	Prg	MDIO Interrupt from Any GPHY The interrupt interrupts an external block such as a higher-level management entity or a device controller of an SoC, on detection of certain events and states inside the GPHY device. Voltage Domain: 1.8 V / 3.3 V
	GPIO4	Prg		General Purpose IO 4 Either input or output mode. The output characteristic is either open drain or push-pull. Voltage Domain: 1.8 V / 3.3 V
K17	MDC_S	I	Prg	MDIO Slave Clock The external controller provides the serial clock of up to 25 MHz on this input. Voltage Domain: 1.8 V / 3.3 V
	GPIO5	Prg		General Purpose IO 5 Either input or output mode. The output characteristic is either open drain or push-pull. Voltage Domain: 1.8 V / 3.3 V
K16	MDIO_S	I/O	Prg	MDIO Slave Data Input/Output The external controller uses this signal to address internal registers and to transfer data to and from the internal registers. Voltage Domain: 1.8 V / 3.3 V
	GPIO6	Prg		General Purpose IO 6 Either input or output mode. The output characteristic is either open drain or push-pull. Voltage Domain: 1.8 V / 3.3 V

2.2.3.4 QSPI Interface

Table 7 QSPI Management Interface Signals

Ball No.	Name	Pin Type	Buffer Type	Function
R17	QSPI_D0	I/O	Prg	QSPI Data 0 QSPI interface data 0 Voltage Domain: 3.3 V
	GPIO9	Prg		General Purpose IO 9 Either input or output mode. The output characteristic is either open drain or push-pull. Voltage Domain: 3.3 V
R16	QSPI_D1	I/O	Prg	QSPI Data 1 QSPI interface data 1 Voltage Domain: 3.3 V
	GPIO10	Prg		General Purpose IO 10 Either input or output mode. The output characteristic is either open drain or push-pull. Voltage Domain: 3.3 V
P16	QSPI_D2	I/O	Prg	QSPI Data 2 QSPI interface data 2 Voltage Domain: 3.3 V
	GPIO11	Prg		General Purpose IO 11 Either input or output mode. The output characteristic is either open drain or push-pull. Voltage Domain: 3.3 V
P17	QSPI_D3	I/O	Prg	QSPI Data 3 QSPI interface data 3 Voltage Domain: 3.3 V
	GPIO12	Prg		General Purpose IO 12 Either input or output mode. The output characteristic is either open drain or push-pull. Voltage Domain: 3.3 V
M15	QSPI_CLK	O	Prg	QSPI Clock QSPI interface clock output Voltage Domain: 3.3 V
	GPIO13	Prg		General Purpose IO 13 Either input or output mode. The output characteristic is either open drain or push-pull. Voltage Domain: 3.3 V

Table 7 QSPI Management Interface Signals (cont'd)

Ball No.	Name	Pin Type	Buffer Type	Function
N15	QSPI_CS	O	Prg	QSPI Chip Select QSPI interface chip select Voltage Domain: 3.3 V
	GPIO14	Prg		General Purpose IO 14 Either input or output mode. The output characteristic is either open drain or push-pull. Voltage Domain: 3.3 V
L15	QSPI_RST	O	Prg	QSPI Reset QSPI Reset Voltage Domain: 3.3 V
	GPIO15	Prg		General Purpose IO 15 Either input or output mode. The output characteristic is either open drain or push-pull. Voltage Domain: 3.3 V

2.2.3.5 I²C Interface

Table 8 I²C Management Interface Signals

Ball No.	Name	Pin Type	Buffer Type	Function
F18	I2C_SCL_0	O	Prg	I²C 0 Clock Output I ² C 0 interface clock output Voltage Domain: 3.3 V
	GPIO16	Prg		General Purpose IO 16 Either input or output mode. The output characteristic is either open drain or push-pull. Voltage Domain: 3.3 V
F17	I2C_SDA_0	I/O	Prg	I²C 0 Data I ² C 0 interface data Voltage Domain: 3.3 V
	GPIO17	Prg		General Purpose IO 17 Either input or output mode. The output characteristic is either open drain or push-pull. Voltage Domain: 3.3 V

2.2.3.6 Reset Interface

Table 9 Reset Signals

Ball No.	Name	Pin Type	Buffer Type	Function
E4	HRSTN	I	PU	Hardware Reset Asynchronous active low device reset Voltage Domain: 3.3 V

2.2.3.7 LED/UART/JTAG Interface
Table 10 LED and Debug Interface Signals

Ball No.	Name	Pin Type	Buffer Type	Function
LED Signals				
E1	PHYLED1_0	I/O		GPHY LED1 for Port 0 LED control output, drives single-color or dual color LEDs. Voltage Domain: 3.3 V
	GPIO20	Prg	Prg	General Purpose IO 20 Either input or output mode. The output characteristic is either open drain or push-pull. Voltage Domain: 3.3 V
	FW_UTXD	O		Firmware UART Data Output Firmware UART interface data output Voltage Domain: 3.3 V
E2	PHYLED2_0	I/O		GPHY LED2 for Port 0 LED control output, drives single-color or dual color LEDs. Voltage Domain: 3.3 V
	GPIO21	Prg	Prg	General Purpose IO 21 Either input or output mode. The output characteristic is either open drain or push-pull. Voltage Domain: 3.3 V
	FW_URXD	I		Firmware UART Data Input Firmware UART interface data input Voltage Domain: 3.3 V
E3	PHYLED3_0	I/O		GPHY LED3 for Port 0 LED control output, drives single-color or dual color LEDs. Voltage Domain: 3.3 V
	GPIO22	Prg	Prg	General Purpose IO 22 Either input or output mode. The output characteristic is either open drain or push-pull. Voltage Domain: 3.3 V
F2	PHYLED1_1	I/O		GPHY LED1 for Port 1 LED control output, drives single-color or dual color LEDs. Voltage Domain: 3.3 V
	GPIO23	Prg	Prg	General Purpose IO 23 Either input or output mode. The output characteristic is either open drain or push-pull. Voltage Domain: 3.3 V
	FW_UTXD	O		Firmware UART Data Output Firmware UART interface data output Voltage Domain: 3.3 V

Table 10 LED and Debug Interface Signals (cont'd)

Ball No.	Name	Pin Type	Buffer Type	Function
F3	PHYLED2_1	I/O		GPHY LED2 for Port 1 LED control output, drives single-color or dual color LEDs. Voltage Domain: 3.3 V
	GPIO24	Prg	Prg	General Purpose IO 24 Either input or output mode. The output characteristic is either open drain or push-pull. Voltage Domain: 3.3 V
G1	PHYLED3_1	I/O		GPHY LED3 for Port 1 LED control output, drives single-color or dual color LEDs. Voltage Domain: 3.3 V
	GPIO25	Prg	Prg	General Purpose IO 25 Either input or output mode. The output characteristic is either open drain or push-pull. Voltage Domain: 3.3 V
G2	PHYLED1_2	I/O		GPHY LED1 for Port 2 LED control output, drives single-color or dual color LEDs. Voltage Domain: 3.3 V
	GPIO26	Prg	Prg	General Purpose IO 26 Either input or output mode. The output characteristic is either open drain or push-pull. Voltage Domain: 3.3 V
	TDI	I		JTAG Serial Test Data Input Voltage Domain: 3.3 V <i>Note: No external pull-up required.</i>
	FW_UTXD	O		Firmware UART Data Output Firmware UART interface data output Voltage Domain: 3.3 V
H2	PHYLED2_2	I/O		GPHY LED2 for Port 2 LED control output, drives single-color or dual color LEDs. Voltage Domain: 3.3 V
	GPIO27	Prg	Prg	General Purpose IO 27 Either input or output mode. The output characteristic is either open drain or push-pull. Voltage Domain: 3.3 V
	TMS	I		JTAG Test Mode Select Voltage Domain: 3.3 V <i>Note: No external pull-up required.</i>
G3	PHYLED3_2	I/O		GPHY LED3 for Port 2 LED control output, drives single-color or dual color LEDs. Voltage Domain: 3.3 V
	GPIO28	Prg	Prg	General Purpose IO 28 Either input or output mode. The output characteristic is either open drain or push-pull. Voltage Domain: 3.3 V

Table 10 LED and Debug Interface Signals (cont'd)

Ball No.	Name	Pin Type	Buffer Type	Function
J1	PHYLED1_3	I/O		GPHY LED1 for Port 3 LED control output, drives single-color or dual color LEDs. Voltage Domain: 3.3 V
	GPIO29	Prg	Prg	General Purpose IO 29 Either input or output mode. The output characteristic is either open drain or push-pull. Voltage Domain: 3.3 V
	TCK	I		JTAG Test Clock The signals TDI, TDO, and TMS are synchronous, subject to this JTAG test clock. Voltage Domain: 3.3 V
	FW_UTXD	O		Firmware UART Data Output Firmware UART interface data output Voltage Domain: 3.3 V
J2	PHYLED2_3	I/O		GPHY LED2 for Port 3 LED control output, drives single-color or dual color LEDs. Voltage Domain: 3.3 V
	GPIO30	Prg	Prg	General Purpose IO 30 Either input or output mode. The output characteristic is either open drain or push-pull. Voltage Domain: 3.3 V
	TDO	I/O		JTAG Serial Test Data Output JTAG test data output. Voltage Domain: 3.3 V <i>Note: No external pull-up required.</i>
H3	PHYLED3_3	I/O		GPHY LED3 for Port 3 LED control output, drives single-color or dual color LEDs. Voltage Domain: 3.3 V
	GPIO31	Prg	Prg	General Purpose IO 31 Either input or output mode. The output characteristic is either open drain or push-pull. Voltage Domain: 3.3 V
J3	PHYLED1_4	I/O		GPHY LED1 for Port 4 LED control output, drives single-color or dual color LEDs. Voltage Domain: 3.3 V
	GPIO32	Prg	Prg	General Purpose IO 32 Either input or output mode. The output characteristic is either open drain or push-pull. Voltage Domain: 3.3 V
	FW_UTXD	O		Firmware UART Data Output Firmware UART interface data output Voltage Domain: 3.3 V

Table 10 LED and Debug Interface Signals (cont'd)

Ball No.	Name	Pin Type	Buffer Type	Function
K2	PHYLED2_4	I/O		GPHY LED2 for Port 4 LED control output, drives single-color or dual color LEDs. Voltage Domain: 3.3 V
	GPIO33	Prg	Prg	General Purpose IO 33 Either input or output mode. The output characteristic is either open drain or push-pull. Voltage Domain: 3.3 V
L3	PHYLED3_4	I/O		GPHY LED3 for Port 4 LED control output, drives single-color or dual color LEDs. Voltage Domain: 3.3 V
	GPIO34	Prg	Prg	General Purpose IO 34 Either input or output mode. The output characteristic is either open drain or push-pull. Voltage Domain: 3.3 V
M1	PHYLED1_5	I/O		GPHY LED1 for Port 5 LED control output, drives single-color or dual color LEDs. Voltage Domain: 3.3 V
	GPIO35	Prg	Prg	General Purpose IO 35 Either input or output mode. The output characteristic is either open drain or push-pull. Voltage Domain: 3.3 V
	FW_UTXD	O		Firmware UART Data Output Firmware UART interface data output Voltage Domain: 3.3 V
M3	PHYLED2_5	I/O		GPHY LED2 for Port 5 LED control output, drives single-color or dual color LEDs. Voltage Domain: 3.3 V
	GPIO36	Prg	Prg	General Purpose IO 36 Either input or output mode. The output characteristic is either open drain or push-pull. Voltage Domain: 3.3 V
L2	PHYLED3_5	I/O		GPHY LED3 for Port 5 LED control output, drives single-color or dual color LEDs. Voltage Domain: 3.3 V
	GPIO37	Prg	Prg	General Purpose IO 37 Either input or output mode. The output characteristic is either open drain or push-pull. Voltage Domain: 3.3 V

Table 10 LED and Debug Interface Signals (cont'd)

Ball No.	Name	Pin Type	Buffer Type	Function
M2	PHYLED1_6	I/O		GPHY LED1 for Port 6 LED control output, drives single-color or dual color LEDs. Voltage Domain: 3.3 V
	GPIO38	Prg	Prg	General Purpose IO 38 Either input or output mode. The output characteristic is either open drain or push-pull. Voltage Domain: 3.3 V
	FW_UTXD	O		Firmware UART Data Output Firmware UART interface data output Voltage Domain: 3.3 V
N3	PHYLED2_6	I/O		GPHY LED2 for Port 6 LED control output, drives single-color or dual color LEDs. Voltage Domain: 3.3 V
	GPIO39	Prg	Prg	General Purpose IO 39 Either input or output mode. The output characteristic is either open drain or push-pull. Voltage Domain: 3.3 V
N2	PHYLED3_6	I/O		GPHY LED3 for Port 6 LED control output, drives single-color or dual color LEDs. Voltage Domain: 3.3 V
	GPIO40	Prg	Prg	General Purpose IO 40 Either input or output mode. The output characteristic is either open drain or push-pull. Voltage Domain: 3.3 V
P1	PHYLED1_7	I/O		GPHY LED1 for Port 7 LED control output, drives single-color or dual color LEDs. Voltage Domain: 3.3 V
	GPIO41	Prg	Prg	General Purpose IO 41 Either input or output mode. The output characteristic is either open drain or push-pull. Voltage Domain: 3.3 V
	FW_UTXD	O		Firmware UART Data Output Firmware UART interface data output Voltage Domain: 3.3 V
P2	PHYLED2_7	I/O		GPHY LED2 for Port 7 LED control output, drives single-color or dual color LEDs. Voltage Domain: 3.3 V
	GPIO42	Prg	Prg	General Purpose IO 42 Either input or output mode. The output characteristic is either open drain or push-pull. Voltage Domain: 3.3 V

Table 10 LED and Debug Interface Signals (cont'd)

Ball No.	Name	Pin Type	Buffer Type	Function
P3	PHYLED3_7	I/O		GPHY LED3 for Port 7 LED control output, drives single-color or dual color LEDs. Voltage Domain: 3.3 V
	GPIO43	Prg	Prg	General Purpose IO 43 Either input or output mode. The output characteristic is either open drain or push-pull. Voltage Domain: 3.3 V
R3	TRSTN	I		JTAG Test Enabling At logic HIGH, the GPIO pins are used as JTAG interface (TCK, TDI, TDO, and TMS). At logic LOW, the GPIO pins are used in their normal application mode. Voltage Domain: 3.3 V

2.2.3.8 Miscellaneous Signals

Table 11 Miscellaneous Signals

Ball No.	Name	Pin Type	Buffer Type	Function
Reset and Clocking				
E17	XTAL1	AI	A	Crystal: Oscillator Input A crystal must be connected between XTAL1 and XTAL2. Additional load capacitances must tie both pins to GND.
	CLK	AI	A	Crystal Oscillator: Clock Input A clock of 25, 50, or 156.25 MHz must be connected to CLK. See Section 7.7.2 for the clock details. XTAL2 must not be connected.
E16	XTAL2	AO	A	Crystal: Oscillator Output A crystal must be connected between XTAL1 and XTAL2. Additional load capacitances must tie both pins to GND.
J17	GPC0	Prg		General Purpose Clock 0 General purpose clock for external devices. Either input or output mode. Voltage Domain: 3.3 V
	GPIO44	Prg	Prg	General Purpose IO 44 Either input or output mode. The output characteristic is either open drain or push-pull. Voltage Domain: 3.3 V
J18	GPC1	Prg		General Purpose Clock 1 General purpose clock for external devices. Either input or output mode. Voltage Domain: 3.3 V
	GPIO45	Prg	Prg	General Purpose IO 45 Either input or output mode. The output characteristic is either open drain or push-pull. Voltage Domain: 3.3 V
J16	GPC2	Prg		General Purpose Clock 2 General purpose clock for external devices. Either input or output mode. Voltage Domain: 3.3 V
	GPIO46	Prg	Prg	General Purpose IO 46 Either input or output mode. The output characteristic is either open drain or push-pull. Voltage Domain: 3.3 V

Table 11 Miscellaneous Signals (cont'd)

Ball No.	Name	Pin Type	Buffer Type	Function
H17	GPC3	Prg		General Purpose Clock 3 General purpose clock for external devices. Either input or output mode. Voltage Domain: 3.3 V
	GPIO47	Prg	Prg	General Purpose IO 47 Either input or output mode. The output characteristic is either open drain or push-pull. Voltage Domain: 3.3 V
L16	GPIO0	Prg	Prg	General Purpose IO 0 Either input or output mode. The output characteristic is either open drain or push-pull. Voltage Domain: 1.8 V / 3.3 V
	EXTINT0	Prg	Prg	External Interrupt 0 Voltage Domain: 1.8 V / 3.3 V
D5	GPIO1	Prg	Prg	General Purpose IO 1 Either input or output mode. The output characteristic is either open drain or push-pull. Voltage Domain: 3.3 V
	EXTINT1	Prg	Prg	External Interrupt 1 Voltage Domain: 3.3 V
P4	GPIO2	Prg	Prg	General Purpose IO 2 Either input or output mode. The output characteristic is either open drain or push-pull. Voltage Domain: 3.3 V
K4	GPIO3	Prg	Prg	General Purpose IO 3 Either input or output mode. The output characteristic is either open drain or push-pull. Voltage Domain: 3.3 V
L18	GPIO7	Prg		General Purpose IO 7 Either input or output mode. The output characteristic is either open drain or push-pull. Voltage Domain: 1.8 V / 3.3 V
L17	GPIO8	Prg		General Purpose IO 8 Either input or output mode. The output characteristic is either open drain or push-pull. Voltage Domain: 1.8 V / 3.3 V
M17	GPIO18	Prg		General Purpose IO 18 Either input or output mode. The output characteristic is either open drain or push-pull. Voltage Domain: 3.3 V
M16	GPIO19	Prg		General Purpose IO 19 Either input or output mode. The output characteristic is either open drain or push-pull. Voltage Domain: 3.3 V

2.2.3.9 Power Supply for GPHY

Table 12 Power Supply Pins for GPHY

Ball No.	Name	Pin Type	Buffer Type	Function
C12	VDDA3V3_0	PWR		GPHY 0 High Voltage Domain Supply This is the PHY 0 AFE 3.3 V supply.
C10	VDDA3V3_1	PWR		GPHY 1 High Voltage Domain Supply This is the PHY 1 AFE 3.3 V supply.
C8	VDDA3V3_2	PWR		GPHY 2 High Voltage Domain Supply This is the PHY 2 AFE 3.3 V supply.
C6	VDDA3V3_3	PWR		GPHY 3 High Voltage Domain Supply This is the PHY 3 AFE 3.3 V supply.
T6	VDDA3V3_4	PWR		GPHY 4 High Voltage Domain Supply This is the PHY 4 AFE 3.3 V supply.
T8	VDDA3V3_5	PWR		GPHY 5 High Voltage Domain Supply This is the PHY 5 AFE 3.3 V supply.
T10	VDDA3V3_6	PWR		GPHY 6 High Voltage Domain Supply This is the PHY 6 AFE 3.3 V supply.
T12	VDDA3V3_7	PWR		GPHY 7 High Voltage Domain Supply This is the PHY 7 AFE 3.3 V supply.
D8	VDDA1V8_0	PWR		GPHY 0, 1, 2, 3 AFE Voltage Domain Supply This is the 1.8 V supply for PHY 0 to PHY 3 AFE voltage domain. It supplies mixed signal blocks in the AFE.
R8	VDDA1V8_1	PWR		GPHY 4, 5, 6, 7 AFE Voltage Domain Supply This is the 1.8 V supply for PHY 4 to PHY 7 AFE voltage domain. It supplies mixed signal blocks in the AFE.
F7, F12	VDDA0V8_0	PWR		GPHY 0, 1, 2, 3 Low Voltage Domain Supply This is the supply for PHY 0 to PHY 3 low voltage domain. It supplies mixed signal blocks in the AFE.
N7, N12	VDDA0V8_1	PWR		GPHY 4, 5, 6, 7 Low Voltage Domain Supply This is the supply for PHY 4 to PHY 7 low voltage domain. It supplies mixed signal blocks in the AFE.
G4, H4, L4, M4	VDD3V3PAD0	PWR		Power Supply Digital Domain 3.3 V 3.3 V Voltage Digital Power Supply
F15, G15, P15	VDD3V3PAD1	PWR		Power Supply Digital Domain 3.3 V 3.3 V Voltage Digital Power Supply
J15	VDDP_PAD	PWR		Power Supply Digital Domain 1.8 V / 3.3 V 3.3 V or 1.8 V Pad Voltage Digital Power Supply based on pin strapping.

Table 12 Power Supply Pins for GPHY (cont'd)

Ball No.	Name	Pin Type	Buffer Type	Function
G6, H6, G8, H8, H10, H11, G12, G13, J7, K7, J9, K9, L6, M6, L8, M8, L10, L11, M12, M13	VDDD0V8_COR	PWR		Power Supply Digital Domain 0.8 V 0.8 V Core Voltage Digital Power Supply
J13	VDDA1V8PORXO	PWR		Power Supply Domain 1.8 V
D9	VDDA1V8_0	PWR		Power Supply Domain 1.8 V
R9	VDDA1V8_1	PWR		Power Supply Domain 1.8 V
F10, G10	VDDA1V2CDB0	PWR		Power Supply Domain 1.2 V
M10, N10	VDDA1V2CDB1	PWR		Power Supply Domain 1.2 V
F9	VDDA0V8_0	PWR		Power Supply Domain 0.8 V
N9	VDDA0V8_1	PWR		Power Supply Domain 0.8 V
L13	VDDA1V8_PLL	PWR		Power Supply Domain 1.8 V
J11	VDDD0V8REF	PWR		Power Supply Digital Domain 0.8 V
K11	VDDD0V8POST	PWR		Power Supply Digital Domain 0.8 V
K13	VDDA1V8_PVT	PWR		Power Supply Domain 1.8 V
J12	VCC1V8_OTP	PWR		Power Supply Domain 1.8 V

2.2.3.10 Power Supply for USXGMII

Table 13 Power Supply Pins for USXGMII

Ball No.	Name	Pin Type	Buffer Type	Function
C15, D14	VA0V8_0	PWR		USXGMII 0 - 0.8 V Analog Domain Supply
D15	VPHA1V8_0	PWR		USXGMII 0 - 1.8 V Domain Supply
R14, T15	VA0V8_1	PWR		USXGMII 1 - 0.8 V Analog Domain Supply
R15	VPHA1V8_1	PWR		USXGMII 1 - 1.8 V Domain Supply

2.2.3.11 Power Supply for TPI (AFE)

Table 14 Power Supply Pins for TPI (AFE)

Ball No.	Name	Pin Type	Buffer Type	Function
A1, A16, C4, C5, C7, C9, C11, C13, C14, D2, D6, D7, D10, D12, D13, F6, F8, F11, F13	TPVSSA_0	GND		Analog Ground
N6, N8, N11, N13, R2, R6, R7, R10, R12, R13, T4, T5, T7, T9, T11, T13, T14, V1, V16	TPVSSA_1	GND		Analog Ground

2.2.3.12 Ground

Table 15 Ground Pins

Ball No.	Name	Pin Type	Buffer Type	Function
D3, D4, E15, F4, G7, H7, G9, H9, G11, H15, H16, J4, J6, K6, J8, K8, J10, K10, K1, K3, K15, L7, M7, L9, M9, M11, L12, N4, N16, R4, R5, H12, K12	VSSD	GND		Digital Ground
A18, B18, C16, D18, R18, T16, U18, V18	UVSS	GND		USXGMII Ground
D16, D17, F16, H13	VSS_XO	GND		XO Device Ground XO ground

2.2.3.13 Not Connected Signals

Table 16 Not Connected Signals

Ball No.	Name	Pin Type	Buffer Type	Function
G17, G18, N17, N18	NC	-	-	No Connect These pins should not be connected.

3 Functional Description

3.1 Power Supply, Clock, and Reset

This section provides the information required to power up the MxL86288L.

3.1.1 Power Supply

These four power supply rails are required: 3.3 V, 0.8 V, 1.8 V, and 1.2 V. [Section 7.7.1](#) contains the power-up sequence.

3.1.2 Clock

An internal PLL circuit generates the required internal clocks, based on an external reference clock.

The available options are:

- An external 25 MHz crystal connected to the MxL86288L. [Section 7.7.9](#) documents the required crystal specification.
- 25 MHz direct from an external oscillator
- An external CML/LVPECL reference clock operating at 50 MHz
- An external LVPECL reference clock operating at 156.25 MHz

3.1.3 Reset Generation

The external hardware reset input (HRSTN pin) resets all the hardware modules including the pin strapping information during boot:

- Driving the HRSTN pin low causes an asynchronous reset of the MxL86288L system.
- Releasing the HRSTN pin high triggers the power-on sequence.

The HRSTN pin is internally connected to a weak internal pull-up resistor.

3.1.4 Power-On Sequence

The MxL86288L powers on when the power is applied and the HRSTN pin is high. See [Figure 18](#).

The steps executed at power on are:

1. Lock the internal PLL.
2. Read the pin strap information, see [Section 3.1.5](#) for more information.
3. Boot the microprocessor from the internal ROM.
4. In flashless mode, wait for the firmware to download into on-chip memory.
5. Authenticate the firmware image in the flash memory device or on-chip memory.
6. Auto-negotiate the link speeds for the Ethernet TPI and USXGMII interfaces.
7. Train and link up each interface in accordance with the IEEE 802.3 [\[2\]](#) standards.

3.1.5 Configuration by Pin Strapping

The MxL86288L is configurable by means of pin strapping on a number of the GPIO pins. The pin strapping configurations are captured during the chip power-on sequence until the reset initialization is complete.

The pin strap values are set to logical high or low by connecting the corresponding pin via an external 1 kΩ resistor to either ground or the pin supply voltage.

[Table 17](#) and [Table 18](#) describe the pin strap mapping.

Table 17 Pin Names Used for Pin Strapping

Ball Name	Ball Number	Configuration Item Description
GPC1	J18	PS_PHY_MADDR(4)
GPC2	J16	PS_PHY_MADDR(3)
GPC3	H17	PS_CLK_SEL
GPIO1	D5	PS_CLK_SEL1
GPIO2	P4	PS_RJ45_TAB
MDINT	G16	PS_MDINT_POLARITY
GPIO3	K4	PS_MDIO_VOLTAGE
GPC0	J17	PS_SUPER_ISOLATE
QSPI_CS	N15	PS_FLASHLESS

Table 18 Pin Strapping Configuration Description

Pin Strapping Signals	Description
PS_PHY_MADDR(4:3)	<p>MDIO PHY Address</p> <p>Specifies the most significant two bits of the MDIO address. The lowest three bits are hard-coded to 0, 1, 2, 3, 4, 5, 6, and 7 for each BASE-T port of the MxL86288L.</p>
PS_MDINT_POLARITY	<p>MDIO Interrupt Polarity</p> <p>Specifies the polarity of the MDIO interrupt.</p> <p>0_B HIGH MDIO interrupt is active high.</p> <p>1_B LOW MDIO interrupt is active low.</p>
PS_RJ45_TAB	<p>RJ45 Tab Configuration</p> <p>Specifies the tab-up or tab-down configuration of the RJ45. Each BASE-T port has the same configuration.</p> <p>1_B DOWN Tab-down</p> <p>0_B UP Tab-up</p>
PS_MDIO_VOLTAGE	<p>MDIO Voltage</p> <p>Specifies whether the maximum voltage level used by the MDIO signals is 3.3 V or 1.8 V.</p> <p>0_H LOW MDIO_S, MDC_S, MDINT, GPIO7, GPIO8, and GPIO0 signal pins are supplied with 1.8 V. In this configuration, V_{DDP} must be supplied with 1.8 V.</p> <p>1_H NORMAL MDIO_S, MDC_S, MDINT, GPIO7, GPIO8, and GPIO0 signal pins are supplied with 3.3 V. In this configuration, V_{DDP} must be supplied with 3.3 V.</p>

Table 18 Pin Strapping Configuration Description (cont'd)

Pin Strapping Signals	Description
PS_CLK_SEL PS_CLK_SEL1	<p>Input Clock Selection Specifies the input clock frequency used. MSB is PS_CLK_SEL1. LSB is PS_CLK_SEL.</p> <p>11_B 25 25 MHz 10_B 50 50 MHz 01_B 156 156.25 MHz 00_B RES Reserved</p>
PS_SUPER_ISOLATE	<p>Super Isolate Specifies whether the PHY is immediately active after a reset or is halted until it is manually activated.</p> <p>0_H HALT The PHYs are inactive after reset. 1_H NORMAL The PHYs are active after reset.</p>
PS_FLASHLESS	<p>Flashless Specifies whether the device operates with or without an external flash memory device.</p> <p>0_H FLASHLESS A flash memory device is not attached. 1_H NORMAL A flash memory device is attached.</p>

Alternative ways to configure the MxL86288L after the boot process are to use the MDIO interface [1] and write into various control registers, as detailed in Section 3.3, or to use the FCA [1].

3.2 MDIO Slave Interface

The SMDIO module and the Ethernet PHY (GPHY) port 0 to 7 are directly attached to the MDIO slave interface as shown in the [Figure 4](#). Each GPHY port supports both IEEE 802.3 clause 22 and clause 45 protocol. It allows direct access to the PHY using the correct MDIO PHY address. The MDIO address used for this access is configurable through pin-strapping, as described in [Section 3.1.5](#).

The SMDIO module provides access to the external flash memory device via the QSPI interface and the internal SRAM. The MxL86288L supports downloading of firmware to the flash memory device or the internal SRAM via the SMDIO module attached to the MDIO bus. In the flash mode, whereby the firmware is downloaded to the external flash memory device, the MDIO address used for this access is the same MDIO address as GPHY port 0 defined by the pin strapping. In the flashless mode, whereby the firmware is downloaded to the internal SRAM, the MDIO address used for this access is $1F_H$. The MxL86288L user guide [\[1\]](#) describing the driver software executed on the external processor must be followed to execute this feature. The SMDIO module supports only IEEE 802.3 clause 22 protocol.

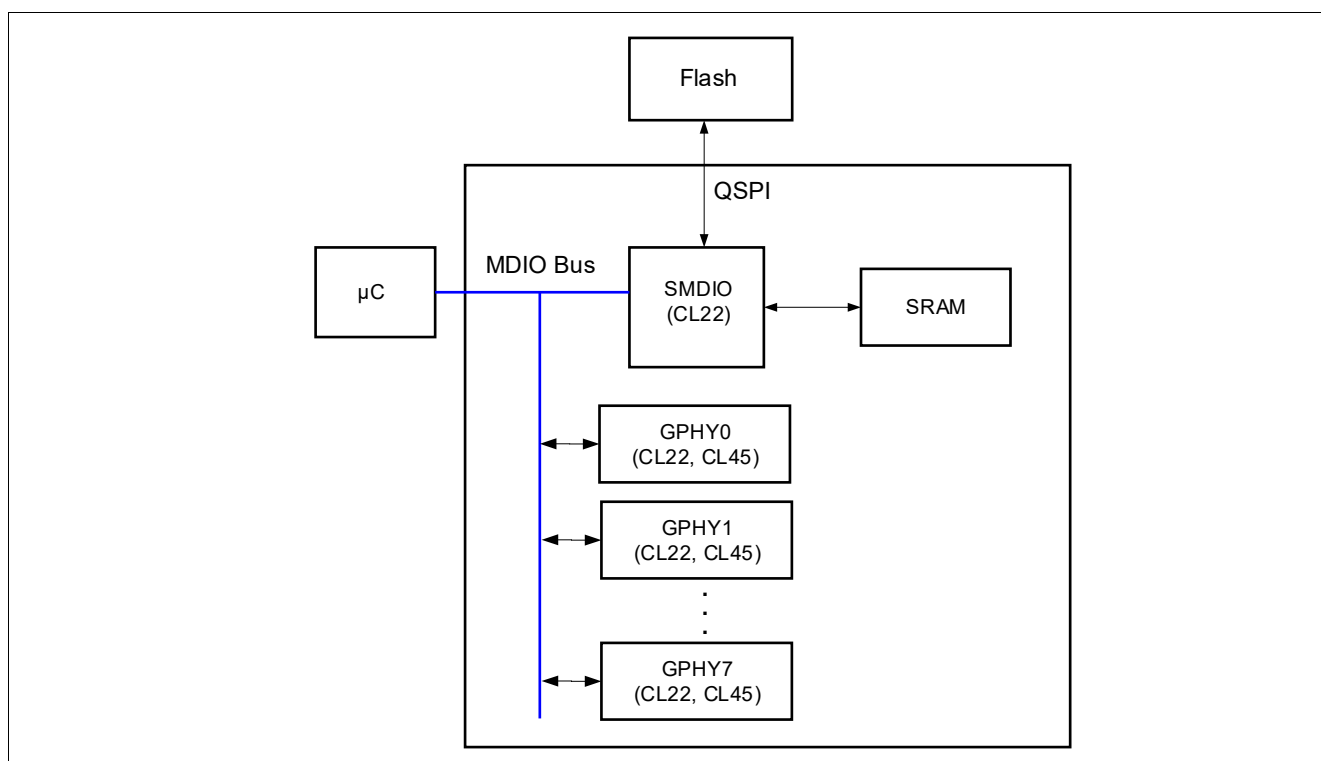

Figure 4 MDIO Slave

When other devices in the system need to be configured through MDIO, they must be connected to the MDIO slave interface and configured such that no addressing conflict arises.

The standard MDIO protocol requires a 32-bit preamble at the beginning of each read or write access. To speed up the data exchange, reduce the preamble down to 1 bit for the second and subsequent accesses.

The standard MDIO protocol uses a clock rate of 2.5 MHz on MDC. To speed up the data exchange, increase the clock applied on MDC_S to the maximum 25 MHz. [Section 7.7.4](#) contains more details on AC characteristics.

3.3 Configuration via MDIO Management Interface

It is possible to connect an external controller's STA to the chip's slave MDIO interface. This allows access to the MDIO and MMD registers standardized in IEEE 802.3, enabling the STA to control the chip configuration and retrieve status information. The MDIO transactions are any of the three types described in IEEE 802.3 Clause 22, Clause 22 Extended, and Clause 45 [2].

Figure 5 and Table 19 show the minimum time required for the MDIO to be available for access.

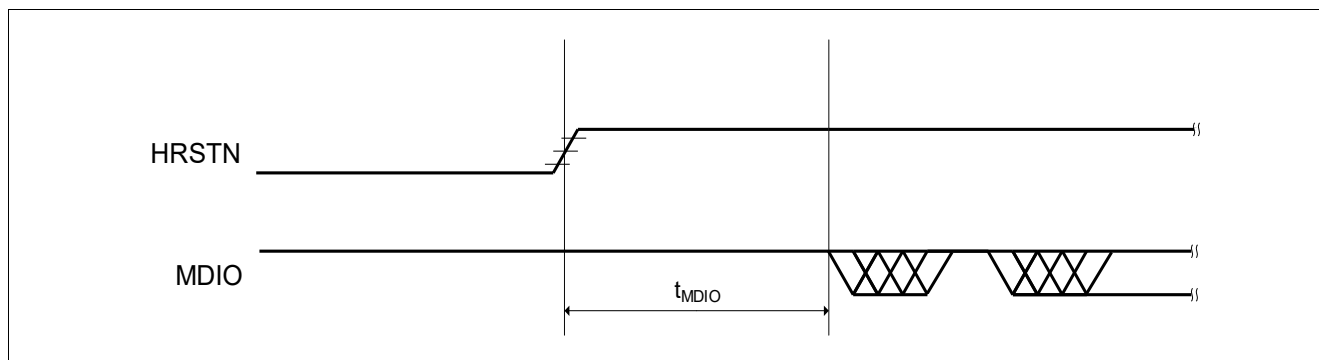

Figure 5 MDIO Access Timing

Table 19 MDIO Ready Timing

Parameter	Symbol	Values			Unit	Note / Test Condition
		Min.	Typ.	Max.		
MDIO Ready Time with Flash Device Attached	T_{MDIO}	750	–	–	ms	Flash Memory Mode This is the minimum amount of time the MDIO interface is unavailable while the MxL86288L boots and the firmware is downloaded from an external flash device using the QSPI interface.
MDIO Ready Time without Flash Device Attached	T_{MDIO}	50	–	–	ms	Flashless Mode This is the minimum amount of time the MDIO interface requires before a firmware download can be initiated from a host MAC SoC using the MDIO interface. MDIO and MMD register access is only available after the firmware download has completed and successfully authenticated.

3.4 I²C Master Interface

The MxL86288L has one chip-integrated I²C master controller. The Inter-IC (I²C) Bus was developed by Philips Semiconductors (now NXP Semiconductors). This specification is compliant with [7].

The I²C is a simple, bi-directional half-duplex bus with data transfers of up to 100 Kbps in standard mode, up to 400 Kbps in fast mode, up to 1000 Kbps in fast mode plus, and up to 3.4 Mbps in high-speed (hs) mode.

I²C provides a protocol allowing devices to communicate directly with each other via two wires. One line is responsible for the clock synchronization (SCL), the other is responsible for the data transfer (SDA). The number of devices connected to the I²C bus is limited only by a maximum bus capacity of 400 pF. Each device is recognized by a unique address.

The two bi-directional bus lines, a Serial Data (SDA) line and a Serial Clock (SCL) line, are connected to a positive supply voltage via pull-up resistors. The output stages of devices must have an open drain to perform the required wired-AND function. One line is pulled low when one of the open-drain transistors is selected. Otherwise, no signal is asserted to the line. The external pull-up resistors lift the level to HIGH.

The I²C specification defines a master/slave relationship where each device works either as a transmitter or a receiver depending on the device function. This functionality is set in the initialization procedure of each module.

Features

- One I²C controller
- Master-mode supported
- Compatible to the I²C specification version 6.0, April 2014¹⁾
- Data transfer in standard- (0 to 100 kBaud), fast- (0 to 400 kBaud), fast mode plus (0 to 1 Mbps) and high-speed mode (0 to 3.4 Mbps)

1) For deviations of timing values compared to the Philips Semiconductors (now NXP Semiconductors*) specifications, see [Chapter 7 Electrical Characteristics](#).

3.5 Quad Serial Peripheral Interface

A Quad Serial Peripheral Interface (QSPI) is equipped to provide access to external Quad-SPI flash memory devices. The MxL86288L requires an external Quad-SPI flash memory to operate in flash mode. Flashless mode allows the firmware to be downloaded via the slave MDIO. The mode is selectable by pin strapping.

Use of an additional QSPI flash memory device depends upon the device operation mode:

- In flash mode, the firmware for the MxL86288L is stored in an external QSPI flash memory device and transferred over the QSPI interface. In flash mode, an external QSPI flash memory device is required.
- In flashless mode, the firmware for the MxL86288L is stored on a host SoC and transferred over the slave MDIO interface. In flashless mode, an external QSPI flash memory device is not required.

The QSPI supports:

- Up to 101.5625 MHz for single/double data rate
- eXecution In Place (XIP), fully memory mapped access for CPU
- Addressing up to 512 MB range

3.5.1 Supported Flash Memory Devices

[Table 20](#) lists the qualified flash memory devices. However, it is possible for the user to select a device not present in the list after consideration of command compatibility and timing compatibility as listed in [Table 21](#). The flash memory device must support 101.5625 MHz single data rate.

Table 20 Supported Flash Memory Devices

Vendor	Model
Macronix	MX25L6433F
Winbond	W25Q64JV-DTR

Table 21 Flash Command and Timing

Instruction	Abbreviation	Command	Command Cycles	Address Cycles	Dummy Cycles	Data Cycles
Write Enable	WREN	06 _H	8	0	0	0
Write Disable	WRDI	04 _H	8	0	0	0
Read ID	RDID	9F _H	8	0	0	24
Read Status Register	RDSR	05 _H	8	0	0	8
Write Status Register	WRSR	01 _H	8	0	0	8
Read Configuration Register	RDCR	15 _H	8	0	0	8
Read Data Bytes	READ	03 _H	8	24	0	8
Fast Read	FREAD	0B _H	8	24	8	8
Quad Read	4READ	EB _H	8	6	10	2
XIP	XIP	EB _H	8	6	10	2 x n ¹⁾
Chip Erase	CE	C7 _H	8	0	0	0
Block Erase	BE	D8 _H	8	24	0	0
Sector Erase	SE	20 _H	8	24	0	0
Page Program	PP	02 _H	8	24	0	8 x n ¹⁾
Reset Enable	RSTEN	66 _H	8	0	0	0
Reset	RST	99 _H	8	0	0	0

1) n is the number of bytes

3.6 GPIO Mapping

Other than the GPIO functionality, the GPIO pins are also shared with other alternative functions. The GPIO pins are configurable to alternative functions, which are based on the pinmux settings as shown in [Table 22](#).

Table 22 GPIO Mapping

Pinmux Mode 0 (Default)	Pinmux Mode 1	Pinmux Mode 2	Pinmux Mode 3
GPIO0	GPIO0	EXTINT0	—
GPIO1	GPIO1	EXTINT1	—
GPIO2	GPIO2	—	—
GPIO3	GPIO3	—	—
MDINT	GPIO4	—	—
MDC_S	GPIO5	—	—
MDIO_S	GPIO6	—	—
—	GPIO7	—	—
—	GPIO8	—	—
QSPI_D0	GPIO9	—	—
QSPI_D1	GPIO10	—	—
QSPI_D2	GPIO11	—	—
QSPI_D3	GPIO12	—	—
QSPI_CLK	GPIO13	—	—
QSPI_CS	GPIO14	—	—
QSPI_RST	GPIO15	—	—
I2C_SCL_0	GPIO16	—	—
I2C_SDA_0	GPIO17	—	—
—	GPIO18	—	—
—	GPIO19	—	—
PHYLED1_0	GPIO20	—	FW_UTXD
PHYLED2_0	GPIO21	—	FW_URXD
PHYLED3_0	GPIO22	—	—
PHYLED1_1	GPIO23	—	—
PHYLED2_1	GPIO24	—	—
PHYLED3_1	GPIO25	—	—
PHYLED1_2	GPIO26	—	TDI
PHYLED2_2	GPIO27	—	TMS
PHYLED3_2	GPIO28	—	—
PHYLED1_3	GPIO29	—	TCK
PHYLED2_3	GPIO30	—	TDO
PHYLED3_3	GPIO31	—	—
PHYLED1_4	GPIO32	—	—
PHYLED2_4	GPIO33	—	—
PHYLED3_4	GPIO34	—	—

Table 22 GPIO Mapping (cont'd)

Pinmux Mode 0 (Default)	Pinmux Mode 1	Pinmux Mode 2	Pinmux Mode 3
PHYLED1_5	GPIO35	—	—
PHYLED2_5	GPIO36	—	—
PHYLED3_5	GPIO37	—	—
PHYLED1_6	GPIO38	—	—
PHYLED2_6	GPIO39	—	—
PHYLED3_6	GPIO40	—	—
PHYLED1_7	GPIO41	—	—
PHYLED2_7	GPIO42	—	—
PHYLED3_7	GPIO43	—	—
GPC0	GPIO44	—	—
GPC1	GPIO45	—	—
GPC2	GPIO46	—	—
GPC3	GPIO47	—	—

3.7 Ethernet PHY Interface

The Ethernet PHY implements the physical layer of the Ethernet standard. It supports Digital Signal Processing (DSP) and Analog Signal Processing (ASP) functions in transmitting data over the twisted pair cable.

3.7.1 Twisted Pair Interface

The Twisted Pair Interface (TPI) of the MxL86288L is fully compliant with IEEE 802.3. The MxL86288L integrates series resistors required to terminate the TPI links with a 100 Ω nominal impedance to facilitate a low-power implementation and reduce PCB costs. As a consequence, it is possible to connect the TPI pins directly via a transformer to the RJ45 connector. Additional external circuitry is required for common-mode termination and rejection as described in [Section 7.8.1](#).

[Figure 6](#) shows a schematic of the TPI circuitry taking these components into account.

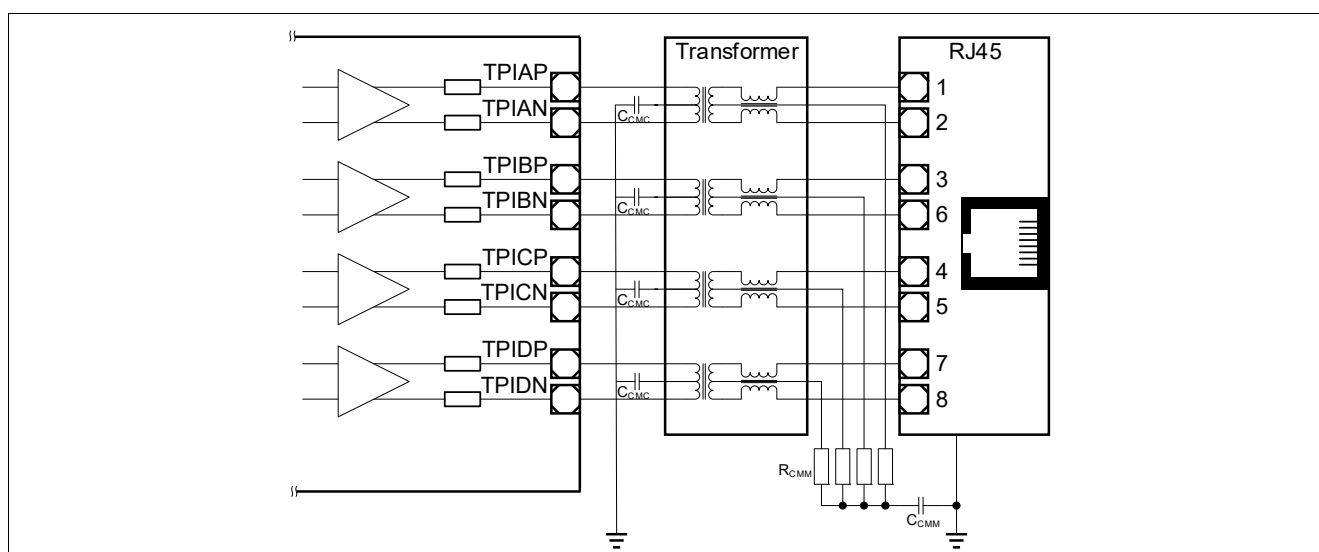

Figure 6 Twisted-Pair Interface of MxL86288L Including Transformer and RJ45 Plug

3.7.2 Transformerless Ethernet

Transformerless Ethernet (TLE) is required for backplane applications where the use of a transformer is not always required to fulfill the galvanic decoupling requirements of the isolation specifications. In such applications, removing the transformer reduces both the external bill of material and the space requirements on the PCB.

As the MxL86288L incorporates a voltage-mode line driver, the only stringent requirement is to use AC coupling, which is achievable using simple SMD type series capacitors. The value of the capacitors is selected such that the high-pass characteristics correspond to an equivalent standard transformer based application. The recommended value is $C_{\text{coupling}} = 100 \text{ nF}$. [Figure 7](#) shows the external circuitry for TLE.

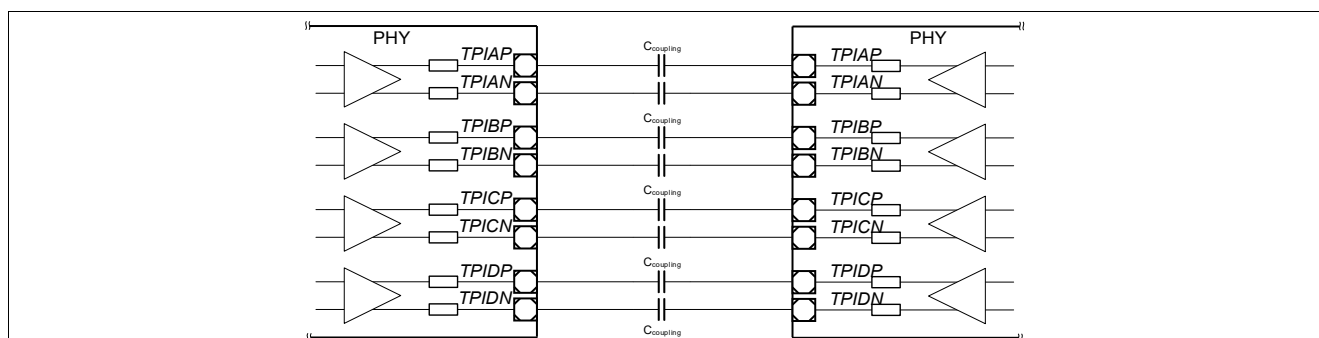

Figure 7 External Circuitry for the Transformerless Ethernet Application

3.7.3 Auto-Negotiation

The MxL86288L supports auto-negotiation (ANEG) as part of the startup procedure to exchange capability information with the link partner. ANEG is enabled at the MxL86288L initialization and its 2.5 Gbps speed capability is advertised. The ANEG procedure is executed according to IEEE 802.3 Clause 28, Clause 40, and IEEE 802.3 Clause 126 [2]. When the link partner does not support ANEG, the MxL86288L determines the link speed configuration using parallel detection as described in Clause 28.

With MDIO commands, it is possible to disable ANEG and change the advertised link rates. The STA is also able to disable ANEG. In this situation, the system configuration must ensure compatibility between link partners to allow link up in a compatible mode.

Attention: *STD_CTRL.DPLX only takes effect when the ANEG process is disabled and the GPHY TPI is not operating in loopback mode, that is, bits STD_CTRL.ANEN and STD_CTRL.LB are set to zero. Forced half-duplex mode (STD_CTRL.DPLX = 0b0) is only supported in 10BASE-T and 100BASE-TX speed modes. This field is ignored for higher speeds. This field is also ignored for transparent mode because half-duplex is not supported in this mode.*

3.7.4 Auto-Downspeed

The auto-downspeed (ADS) feature implements a process to renegotiate the link with a lower speed when the link quality is insufficient. The feature ensures maximum interoperability even in harsh, or inadequate, cable infrastructure environments. In particular, ADS is applied during the 2.5GBASE-T/1000BASE-T training phase. ADS is also required when the quality or characteristics of the cable in use cannot support the advertised speed.

For example, it is possible to advertise 2.5GBASE-T/1000BASE-T during ANEG when both link partners are connected via a cable that does not support the 4-pair Gigabit Ethernet mode. The MxL86288L detects such a configuration to avoid repeating link up failures and clears the 2.5GBASE-T/1000BASE-T capability in the ANEG advertisement registers. After the resulting link down, the next ANEG procedure no longer advertises 1000BASE-T/2.5GBASE-T. The next link up is done at the next advertised speed below 1000 Mbps.

The MxL86288L also executes an ADS procedure when the signal quality is not suited to a 1000BASE-T/2.5GBASE-T link up due to increased alien noise or a loop length that significantly exceeds the standard specification.

When the MxL86288L is configured not to advertise a speed capability below 1000 Mbps, the ADS feature is automatically disabled.

3.7.5 Polarity Reversal Correction

For each of the 4 pairs, the MxL86288L automatically detects and corrects any inversion of the signal polarity on the P and N signals. The detection is done during the auto-negotiation phase. The detected polarity is frozen when the link is established, and remains unchanged until the link is dropped.

The polarity corrections applied are indicated in the register: PMA_MGBT_POLARITY (register 1.130); and are valid after auto-negotiation is complete.

3.7.6 Auto-Crossover Correction

To maximize interoperability, even in inadequate wiring environments, the MxL86288L automatically performs cable crossover (MDI-X) correction. [Table 23](#) lists the supported pair-mappings detectable and correctable by the device.

The MxL86288L automatically detects and corrects crossed cable configuration, where the transmit-receive pairing between partners does not match. The auto-crossover function is fully compliant with IEEE 802.3, Clause 40.4.4 [2], in 1000BASE-T and 2.5GBASE-T mode.

Functional Description

The corrections applied are indicated in the register: PMA_MGBT_POLARITY (register 1.130) and are valid when auto-negotiation is complete.

Table 23 Supported Twisted Pair Mappings on a Cat 5 or Better Cable

Crossover Modes on RJ45 ¹⁾		RJ45 Pinning							
Mode	Description	1	2	3	4	5	6	7	8
11	Straight cable, standard compliant	TPIAP (A+)	TPIAN (A-)	TPIBP (B+)	TPICP (C+)	TPICN (C-)	TPIBN (B-)	TPIDP (D+)	TPIDN (D-)
00	Full Gigabit Ethernet MDI-X This is standard-compliant MDI-X with pair A/B swapped and pair C/D swapped.	TPIBP (B+)	TPIBN (B-)	TPIAP (A+)	TPIDP (D+)	TPIDN (D-)	TPIAN (A-)	TPICP (C+)	TPICN (C-)

1) This pin assignment is according to TIA/EIA-568-A/B.

3.7.7 RJ45 Tab Up or Tab Down Configuration

Figure 8 shows that the RJ45 plug on the system PCB is solderable with the tab either up or down.

The difference between tab up and tab down is a swap in position between A and D, and a swap in position between B and C. The pin strap PS_RJ45_TAB allows the system designer to perform this configuration. As a result, a PCB layout does not need to be modified when a RJ45 tab up or down socket needs to be mounted. The single pin strap is applicable to all ports, which are either all tab down or all tab up.

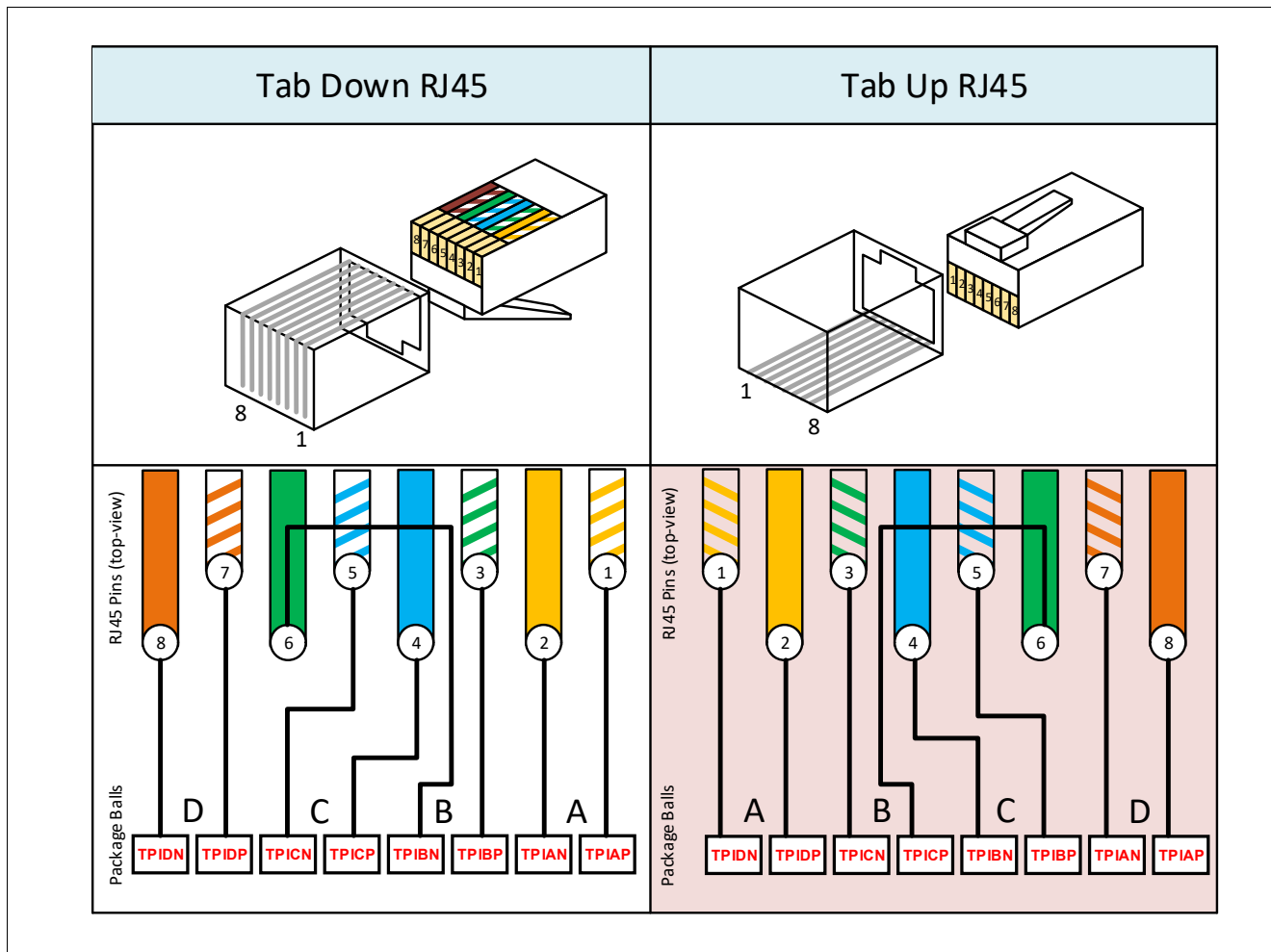

Figure 8 RJ45 Tab Up or Tab Down Configuration

3.7.8 Wake-on-LAN

The MxL86288L supports WoL. The MxL86288L generates an interrupt to an external controller when it detects special WoL Ethernet packets. This allows the controller to enter sleep mode when there is no Ethernet traffic to process, and be woken up when traffic starts. WoL packets are detected at all link speeds. **Figure 9** shows the scenario when connected to an external device.

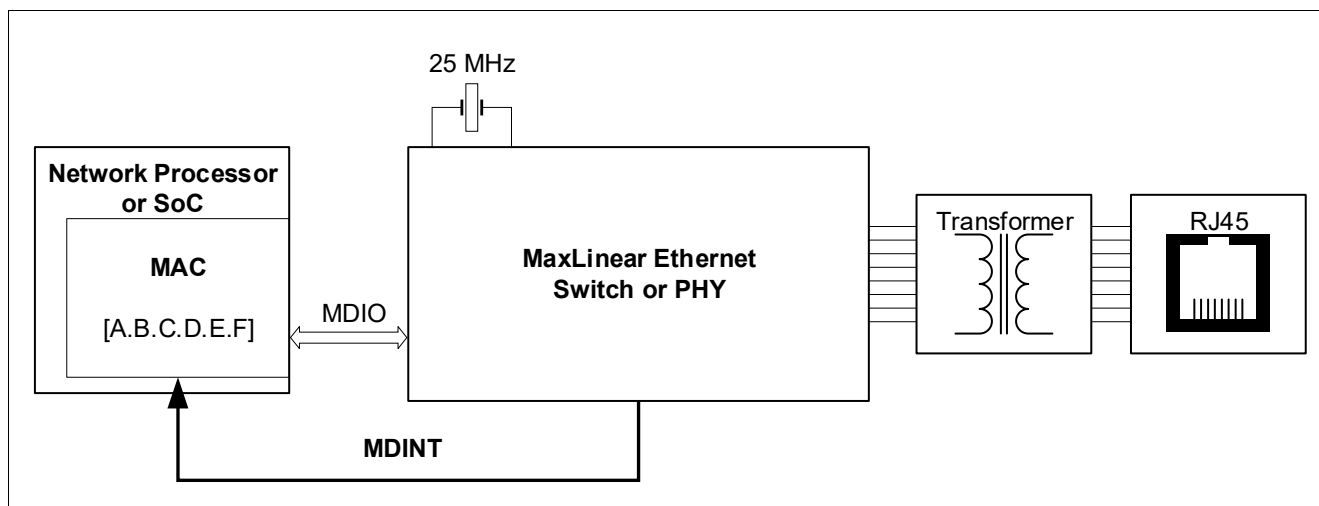

Figure 9 WoL Application Block Diagram

The most commonly used WoL packet is called a magic packet, which contains the MAC address of the device to be woken up, and an optional password called SecureON. The MAC address and the optional SecureON password relevant for the WoL logic inside the MxL86288L are configurable in the WoL MDIO registers in the Vendor Specific 2, VSPEC2 MMD, device described in **Chapter 4**. When such a configured magic packet is received, an MDINT interrupt is issued.

Table 24 gives an example programming sequence for these configuration registers.

Table 24 Programming Sequence for the Wake-on-LAN Functionality

Step	Register Access	Remark
1	MDIO.MMD.WOLAD01 = EEFF _H	Programs the fifth and sixth MAC address bytes.
2	MDIO.MMD.WOLAD23 = CCDD _H	Programs the third and fourth MAC address bytes.
3	MDIO.MMD.WOLAD45 = AAB B _H	Programs the first and second MAC address bytes.
4	MDIO.MMD.WOLPW01 = 4455 _H	Programs the fifth and sixth SecureON password bytes.
5	MDIO.MMD.WOLPW23 = 2233 _H	Programs the third and fourth SecureON password bytes.
6	MDIO.MMD.WOLPW45 = 0011 _H	Programs the first and second SecureON password bytes.
7	MDIO.PHY.IMASK.WOL = 1 _B	Enables the wake-on-LAN interrupt mask.
8	MDIO.MMD.WOLCTRL.WOL.EN = 1 _B	Enables wake-on-LAN functionality.

3.8 Ethernet SerDes Interface

The MxL86288L implements two Ethernet serial data interfaces. [Table 25](#) lists the data rates supported by the USXGMII interface.

The external PHY is able to initiate clause 37 auto-negotiation to change speed and new link up. In USXGMII mode, the interface supports the Packet Control Header (PCH) over preamble to transport control indications between the MAC and the PHY.

Table 25 Ethernet SerDes Interface Feature List

Modes	Baudrate	Coding	Link Speed	IEEE Clause	Auto-Negotiation Clause
10G-QXGMII	10.3125 GT/s	64b/66b	2.5 Gbps, 1 Gbps, 100 Mbps, and 10 Mbps	49	37

3.8.1 Ethernet SerDes Interface Configuration at Power On

The MxL86288L USXGMII interface is configured to operate automatically after reset. It is not necessary for the STA to change the VSPEC1_PM_CTRL.USXGMII_REACH register to operate in this default mode.

These are the steps in the default process:

1. USXGMII auto-negotiation is enabled by default.
2. The TPI configuration after link up defines the corresponding USXGMII PHY-side port configuration. The MAC-side SoC must configure its USXGMII MAC-side interface to match the MxL86288L PHY-side configuration.
3. The MxL86288L API describes the procedure to update the Rx/Tx equalization parameters. The MxL86288L automatically updates the Rx/Tx equalization parameters for standard trace lengths based on the trace length programmed in VSPEC1_PM.USXGMII_REACH. For custom trace lengths, the Rx/Tx equalization parameters are configured using the API. Contact MaxLinear for access to the API documentation.

3.9 LED Interface

This section describes the LED interface.

3.9.1 LED

The MxL86288L allows 24 synchronized LEDs to be used for visual status indication. Each LED pin drives either a single color LED or dual color LED.

3.9.2 LED Configuration

The MxL86288L API describing the driver software executed on the Host SoC must be followed to configure this interface.

Figure 10 shows the external LED connected to either ground or the power rail in single color mode.

Figure 11 and **Figure 12** show the connection of single and dual color LEDs when the pin is also used for pin strapping.

Note: These figures do not show the full recommended circuits with all the necessary components. Refer to the relevant HDK/EVK PCB design documentation for more details.

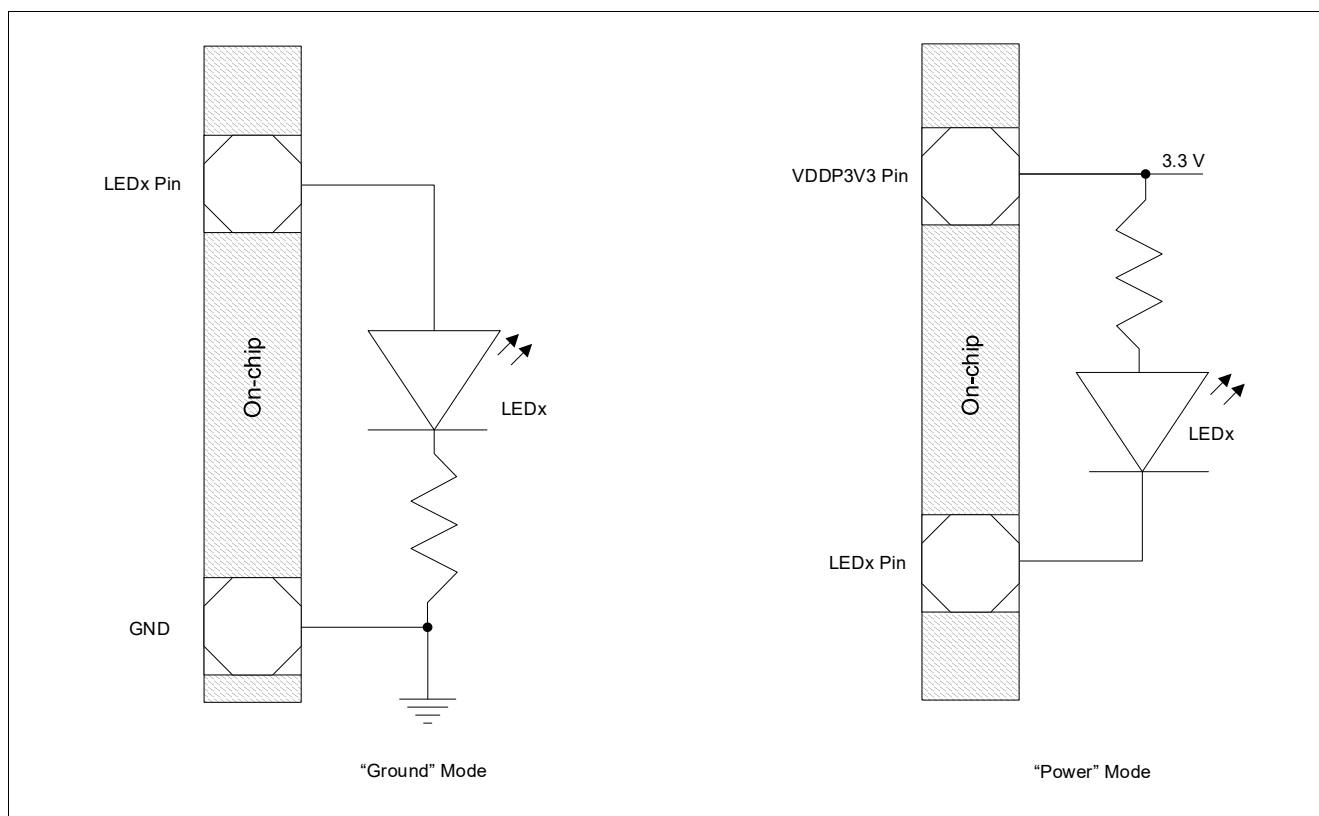

Figure 10 LED Connection Options to Ground or Power Supply

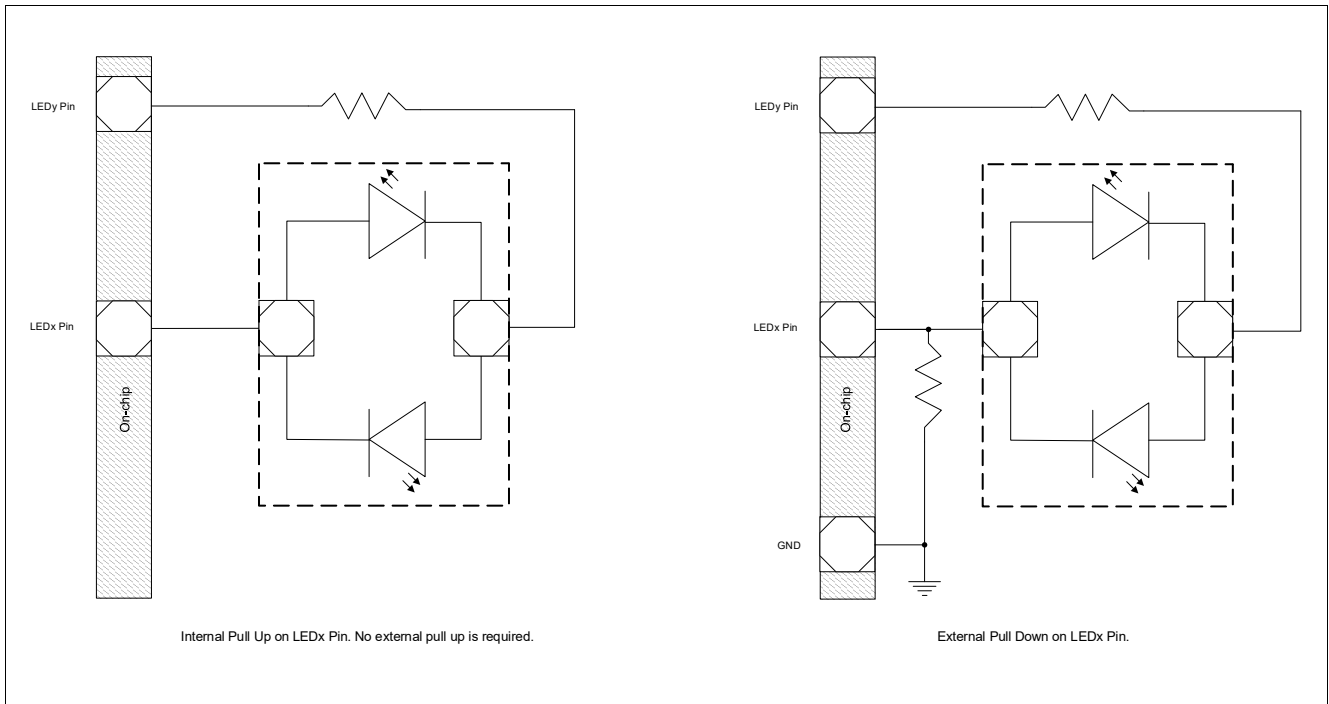

Figure 11 Connection of a Dual Color LED and Configuring Pin Strap Value

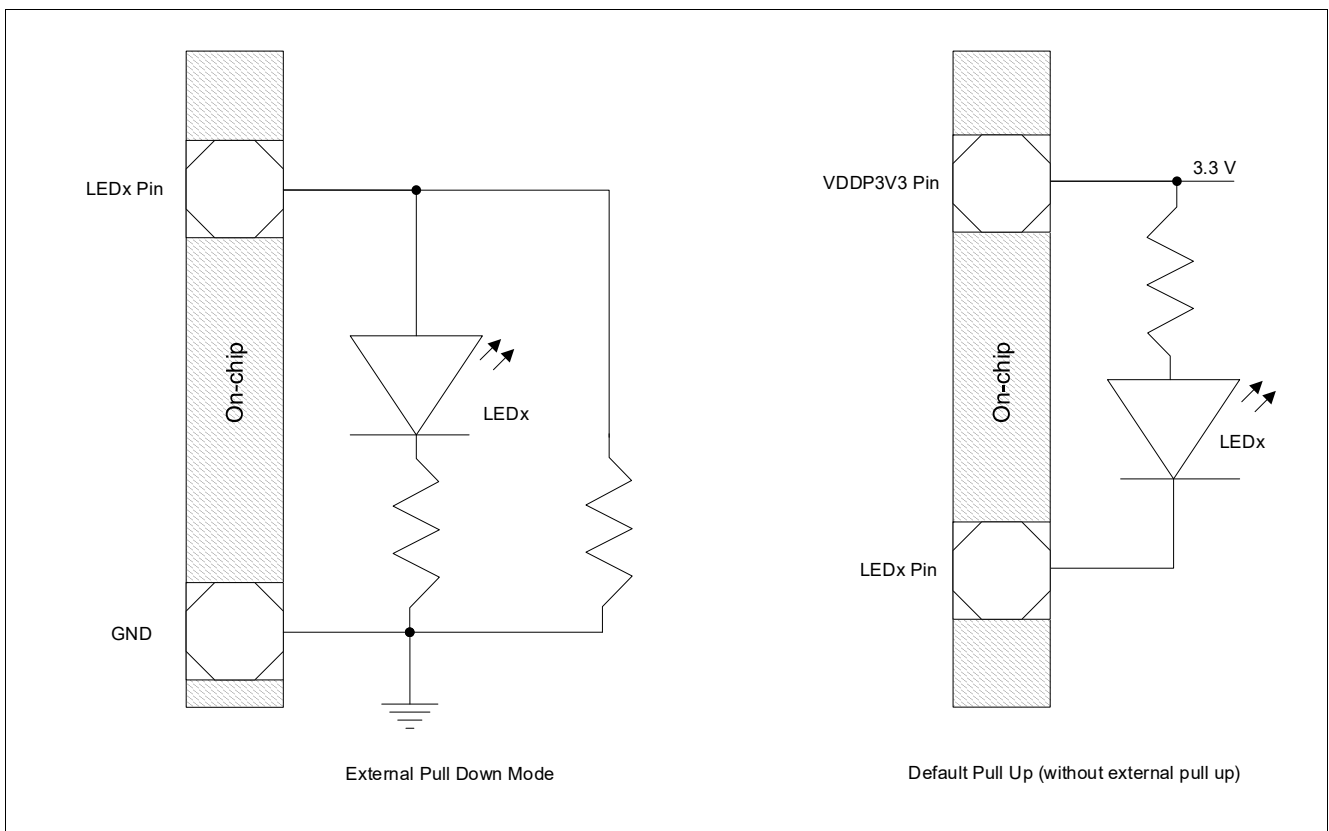

Figure 12 Connection of a Single Color LED and Configuring Pin Strap Value

3.9.3 LED Brightness Control

There are two LED brightness modes configurable by the API, based on the system requirement.

- LED Brightness Level Maximum Mode
Fixed level signal (no pulses) for maximum brightness, also available as a control signal for other purposes.
- LED Brightness Level Control Mode (Constant Mode)
Allows the configuration of 16 levels of LED brightness. See [Brightness Control](#).

Brightness Control

This block controls the brightness of the LED by controlling the time duration for which the LED is on/off. The persistence characteristic of the eye causes it to perceive this as LED brightness. When LED is off, the output is disabled. When the LED is on, the output is enabled. The brightness control affects the LED output enable directly.

[Figure 13](#) shows the brightness control frequency is 81.25 Hz, where each period is divided into 64 slots.

In the LED brightness level maximum mode, the LED is enabled in all 64 slots, as shown in brightness level 0 which is the maximum brightness.

In the LED brightness level control mode, the LED is enabled for n consecutive slots, where n is determined by the configured brightness level. [Figure 13](#) shows the brightness level in active low mode, whereby brightness level 15 is the minimum brightness.

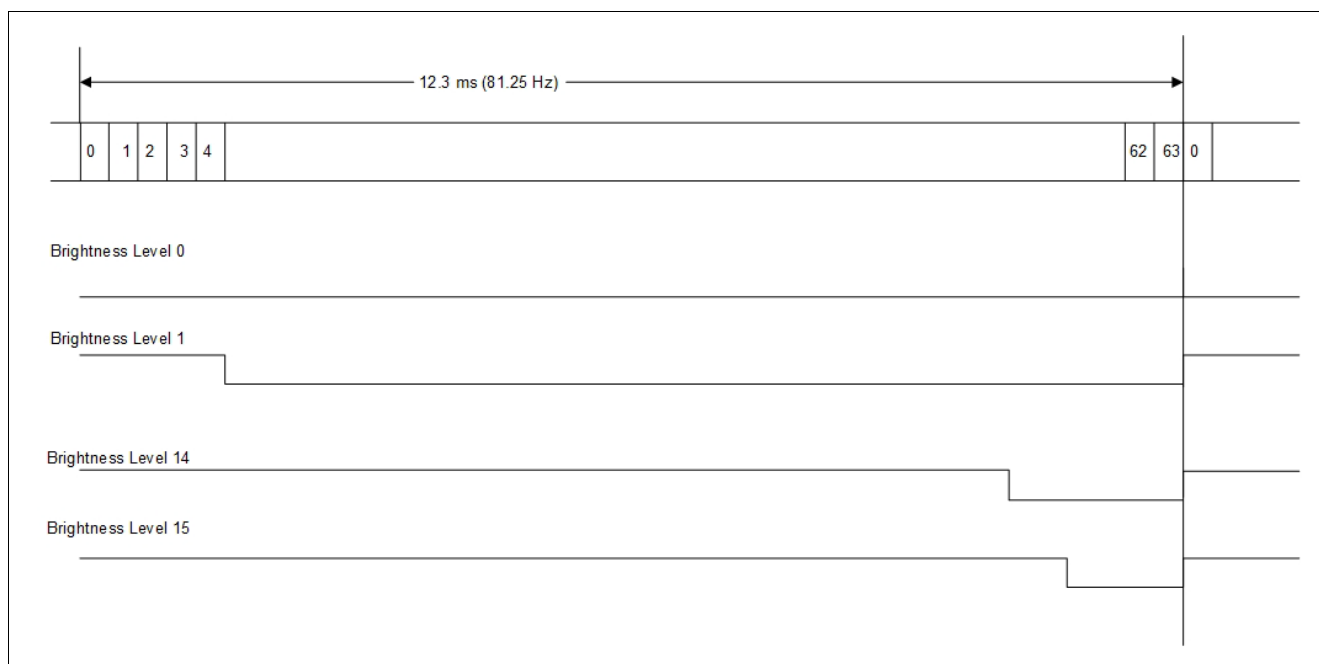

Figure 13 LED Brightness Control by Controlling LED Output Enable/Disable

3.10 Smart-AZ

The Smart-AZ feature is relevant when the 8-Port 2.5 Gigabit Ethernet PHY is connected to a MAC SoC that does not implement the EEE feature in its MAC layer. In this case, the MAC SoC is not able to initiate a transition to the low-power idle state.

To alleviate the limitation of such a MAC SoC, the MxL86288L detects the conditions that may lead to low-power idle and generates the control messages to enter EEE mode in accordance with the IEEE 802.3az standard.

The Smart-AZ feature is not enabled by default and is not supported in transparent mode.

3.11 Preemption

The IEEE 802.3br [2] and IEEE 802.1Qbu standards [9] introduced a one-level Ethernet frame preemption paradigm. In this approach, frames transmitted through a switch output port are classified as express frames or preemptable frames, depending on their priority levels. Express frames are able to preempt preemptable frames. Two frames belonging to the same class are not able to preempt each other. This allows the transmission of non-critical frames to be interrupted by critical frames, hence avoiding critical frames being blocked for long periods of time.

The MxL86288L does not preempt any Ethernet frames or change the order of the Ethernet frames. However, it is preemption-aware and able to identify the various preemption classes. The PCH transports preemption information over the USXGMII interface, consequently the MxL86288L also supports this feature in the PCH.

This feature is relevant in a Time Sensitive Network.

Attention: Preemption is only supported in transparent mode when the MxL86288L is not operating in 10BASE-T. Preemptable frames are dropped in SmartAZ mode.

3.12 Power Management

This section describes the power management functions of the MxL86288L integrated Ethernet PHY.

3.12.1 Power States

Figure 14 illustrates the power states and transitions of each integrated Ethernet PHY.

In this state diagram, the (0.11) syntax corresponds to the value of bit 11 from register 0 in device 0, which is `STD_CTRL.PD`. This is the Power Down (PD) bit in `MDIO STD_CTRL`, described in Chapter 4. The STA is able to use this `STD_CTRL.PD` field to bring the physical interface into the **POWER DOWN State**.

The other states are automatically entered by the MxL86288L depending on the context, and following the EEE protocol. This is done without any intervention from the STA.

The Normal Link Pulse (NLP) and Fast Link Pulse (FLP) are received on the TPI from a link partner and used to wake up the MxL86288L and enter auto-negotiation.

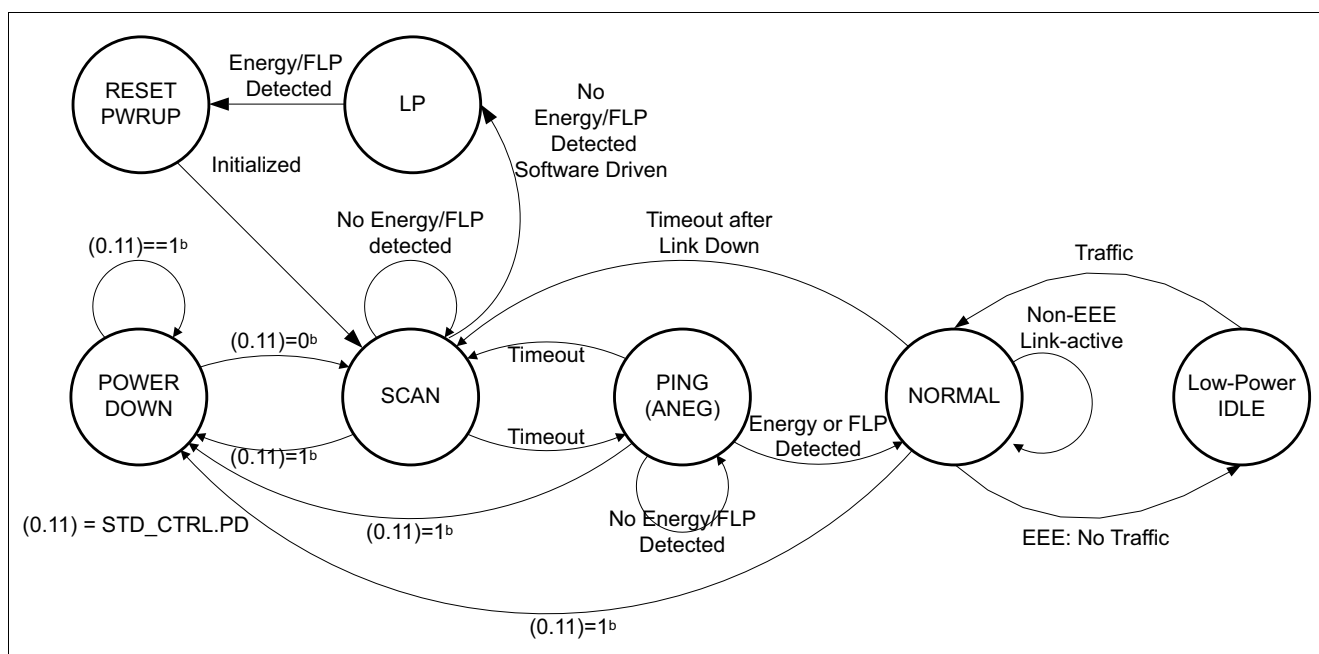

Figure 14 State Diagram for Power Down State Management

3.12.2 RESET PWRUP

The MxL86288L starts up in the RESET Power Up (PWRUP) state after either a hardware reset or power up. After initialization, the PHYs always transition to the **SCAN (ANEG) State**.

3.12.3 POWER DOWN State

The **POWER DOWN State** is entered by setting the PD bit (0.11) of the MDIO standard register `STD_CTRL` to 1, regardless of the current state of the device. The **POWER DOWN State** corresponds to power down as specified in IEEE 802.3, Clause 22.2.4.1.5. Some signal processing blocks are stopped to save energy, but the MxL86288L still responds to MDIO messages.

Exiting the **POWER DOWN State** is triggered by setting the PD bit (0.11) of `STD_CTRL` to 0, which initiates a transition to the **SCAN (ANEG) State**.

3.12.4 SCAN (ANEG) State

The SCAN state differs from the **POWER DOWN State** in that the receiver periodically scans for signal energy or FLP bursts on the TPI. There is no transmission in this state. When an FLP burst is received, the MxL86288L enters the auto-negotiation protocol to exchange capabilities with the link partner and establish a data link in the **NORMAL State**.

3.12.5 PING (ANEG) State

The PING state is similar to the **SCAN (ANEG) State** except that the transceiver transmits an FLP burst onto the TPI for a programmable amount of time. This is used to wake potential link partners from the **POWER DOWN State**. This state corresponds to the state of ANEG described in Clause 28 of the IEEE standard [2].

3.12.6 Low-Power State

The MxL86288L's Low-Power (LP) state is enabled by configuring the MDIO register `PHY_CTL2.LP`. The LP state is entered automatically when there is no Ethernet cable connected to the MxL86288L. The MxL86288L firmware detects this condition when no energy or Link Pulse is present on the TPI and enters the LP state. It is intended to set the MxL86288L into its maximum power saving state. In this state, most digital domains are in reset. Only a minimal amount of circuitry (analog/digital) operates to detect signal energy on the receiver of a TPI and trigger a wake-up.

When the port is in the LP state, the STAs do not have access to the corresponding MDIO/MMD registers.

The LP state is exited upon detection of signal energy on the twisted pair (either NLP or FLP). The port transitions to the **RESET PWRUP** state automatically. The STA host is also able to trigger an LP state exit by applying an API to wake up the specific port that entered the LP state.

It is possible for the STA host to be informed of the LP entry condition. By setting the `PHY_IMASK.LP` bit to ACTIVE, the STA requests the MDINT interrupt from the port when the entry conditions are met. **Figure 15** shows all the LP related control bits and communication mechanism between the STA and the MxL86288L.

It is possible for the STA host to be informed of the LP exit condition. By setting the `VSPEC1_IMASK.CDET` bit to ACTIVE, the STA requests the MDINT interrupt from the port when energy on the link is detected during auto-negotiation. Even when none of the ports are in the LP state, this interrupt is triggered whenever energy is first detected on the link. When the STA triggers the LP state exit via a wake-up request, and there is no energy on the link after the LP state exit, no interrupt is asserted.

Attention: An active-high MDINT in push-pull mode (default is tristate mode) is not supported in the LP mode.

Attention: VSPEC1_IMASK.CDET is not supported in forced speed 10BASE-T/100BASE-TX mode. Auto-negotiation is required to support this feature.

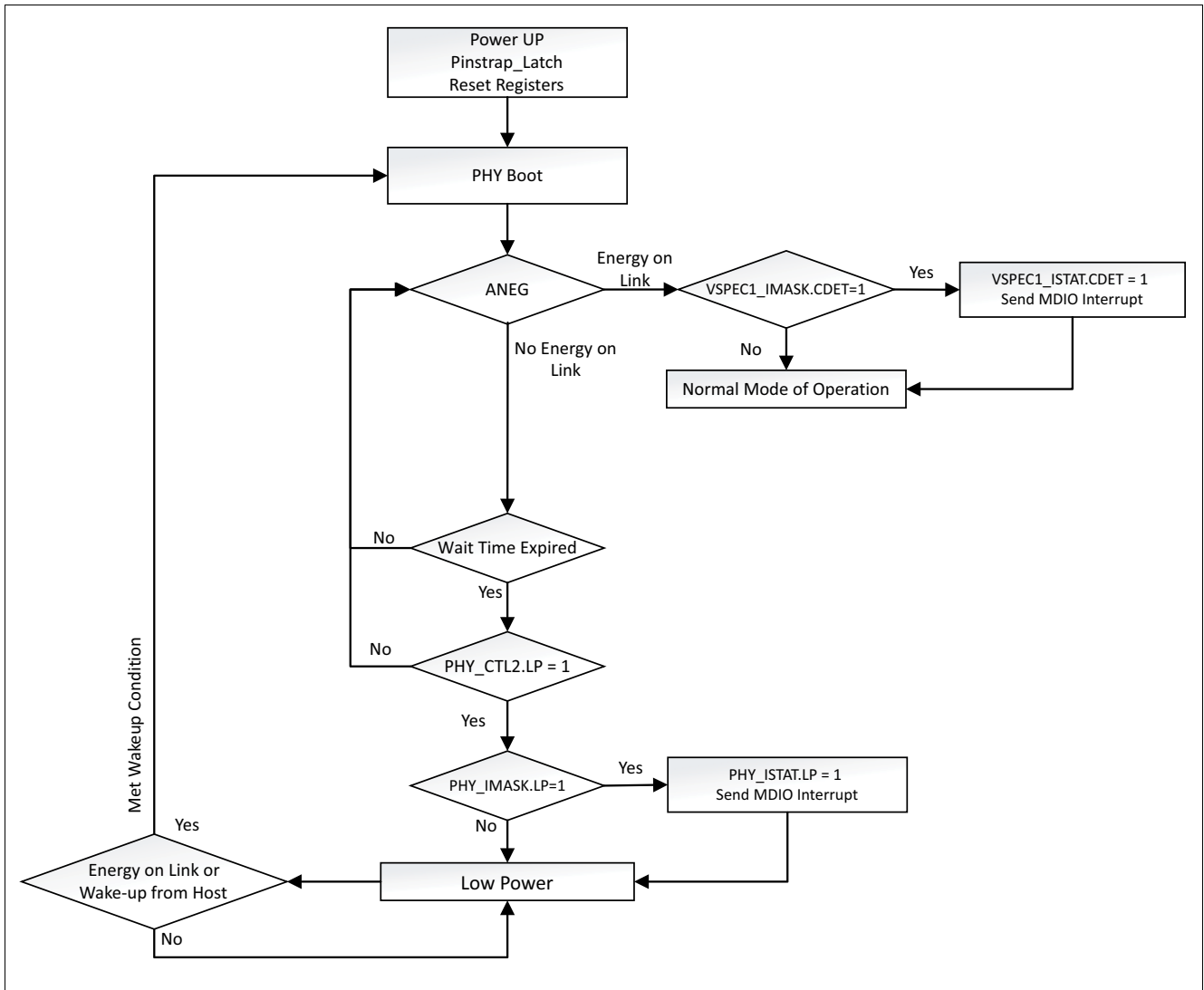

Figure 15 Low Power Sequence

Table 26 Low Power State Entry and Exit Sequence

Step	State	Remark
1	ACTIVE The LP feature is enabled by setting <code>PHY_CTL2.LP = 1</code>	Use the MDIO register <code>PHY_CTL2.LP</code> to enable or disable the LP feature.
2	ANEG, Ability Detect	The firmware detects no energy on the cable when no FLP is received for a long period of time. When the LP feature is not enabled, this time is fixed to between 6.4 and 9.6 seconds. When the LP feature is enabled, this time is configured using the <code>VSPEC1_LOW_POWER_ENTRY_TIME.LPE_TIM</code> register. Time in seconds = 4 x value programmed. Default time is 4 seconds. (<code>VSPEC1_LOW_POWER_ENTRY_TIME.LPE_TIM = 1</code>). There is an initial time of between 2.4 and 5.6 seconds, which adds on to the programmed time.
3	LP Entry Timer	This time is configured with the <code>VSPEC1_LOW_POWER_ENTRY_TIME.LPE_TIM</code> register. The value is set in steps of 4 seconds. The default time is 4 seconds.
4	LP Entry	The MxL86288L saves MDIO LP persistent registers. An interrupt is sent to indicate entry into the LP state.
5	LP State	Power consumption is saved in this state. The MxL86288L listens to energy pulses from the link partner ANEG as a condition to trigger an exit from the LP state. Only a minimal amount of circuitry operates to detect signal energy on TPI and trigger a wake-up. The port LEDs and MDIO interface are disabled.
6	LP Exit (Option 1) Based on energy detected on the cable	The MxL86288L restores the configurations in the MDIO registers. An interrupt is sent to indicate an exit from the LP state.
7	LP Exit (Option 2) Based on a wake-up request from the STA	The STA is able to request an LP exit by using a provided API. The MxL86288L restores the configurations in the MDIO registers. No interrupt is sent to notify LP exit. Since MDIO/MMD register access is unavailable for ports in the low power state, this option is only available if there is at least one port not in the low power state.
8	ANEG, LINK-UP, and ACTIVE	The MxL86288L operates in normal power modes.

These are persistent MDIO registers saved and restored during LP entry-exit.

1. STD_CTRL.SSM
2. STD_CTRL.DPLX
3. STD_CTRL.ANEN
4. STD_CTRL.SSL
5. STD_AN_ADV.TAF
6. STD_AN_ADV.XNP
7. STD_GCTRL.MBTHD
8. STD_GCTRL.MBTDF
9. STD_GCTRL.MSPT
10. STD_GCTRL.MS
11. STD_GCTRL.MSEN
12. PHY_IMASK
13. PHY_CTL1.AMDIX
14. PHY_CTL1.MDIAB
15. PHY_CTL1.MDICD
16. PHY_CTL1.POLA
17. PHY_CTL1.POLB
18. PHY_CTL1.POLC
19. PHY_CTL1.POLD
20. PHY_CTL2.LPI
21. PHY_CTL2.ANPD
22. PHY_CTL2.PSCL
23. PHY_CTL2.LP
24. PHY_CTL2.STICKY
25. PHY_CTL2.SDETP
26. PHY_LED
27. ANEG_CTRL.ANEG_ENAB
28. ANEG_MGBT_AN_CTRL.LDL
29. ANEG_MGBT_AN_CTRL.FR
30. ANEG_MGBT_AN_CTRL.FR2G5BT
31. ANEG_MGBT_AN_CTRL.AB2G5BT
32. ANEG_MGBT_AN_CTRL.PT
33. ANEG_MGBT_AN_CTRL.MS_MAN_EN
34. ANEG_MGBT_AN_CTRL.MSCV
35. ANEG_EEE_AN_ADV1.EEE_100BTX
36. ANEG_EEE_AN_ADV1.EEE_1000BT
37. ANEG_EEE_AN_ADV2.EEE2G5
38. ANEG_MGBT_AN_CTRL2.THPBYP2G5
39. VSPEC1_NBT_DS_CTRL.NO_NRG_RST
40. VSPEC1_NBT_DS_CTRL.DOWNSHIFTEN
41. VSPEC1_NBT_DS_CTRL.DOWNSHIFT_THR
42. VSPEC1_NBT_DS_CTRL.NRG_RST_CNT
43. VSPEC1_NBT_DS_CTRL.FORCE_RST
44. VSPEC1_LED0
45. VSPEC1_LED1
46. VSPEC1_LED2
47. VSPEC1_PM_CTRL
48. VSPEC1_LOW_POWER_ENTRY_TIME.LPE_TIM
49. VSPEC1_IMASK
50. VSPEC1_FRCTL.CAP_EXT

- 51. VSPEC1_FRCTL.CAP_TXDIS
- 52. VSPEC1_FRCTL.CAP_THPBYP
- 53. VSPEC1_FRCTL.CAP_CISCO
- 54. VSPEC1_FRCTL.CAP_IEEE
- 55. VSPEC1_FRCTL.MAX_FR_RETRY
- 56. VSPEC2_WOL_CTRL
- 57. VPSPEC2_WOL_AD01
- 58. VPSPEC2_WOL_AD23
- 59. VPSPEC2_WOL_AD45
- 60. VPSPEC2_WOL_PW01
- 61. VPSPEC2_WOL_PW23
- 62. VPSPEC2_WOL_PW45

3.12.7 NORMAL State

The NORMAL state is used to establish and maintain a link connection. When a connection is dropped, the MxL86288L moves back into the **SCAN (ANEG) State**.

3.12.8 Low Power IDLE State - Energy-Efficient Ethernet

The IEEE 802.3 standard [2] describes the EEE operation supported by the MxL86288L in the various speeds of 100BASE-TX, 1000BASE-T, and 2.5GBASE-T. The general idea of EEE is to save power during periods of low link utilization. Instead of sending active idle data, the transmitters are switched off for a short period of time. This is called the quiet period. The link is kept active by means of a frequent refresh cycle initiated by the PHY itself while in the low power state. This sequence is repeated until a wake request is generated by one of the link partner MACs. The MxL86288L follows the IEEE 802.3 standard regarding EEE. Figure 16 illustrates the principle. This state is entered automatically when the low power idle conditions are met.

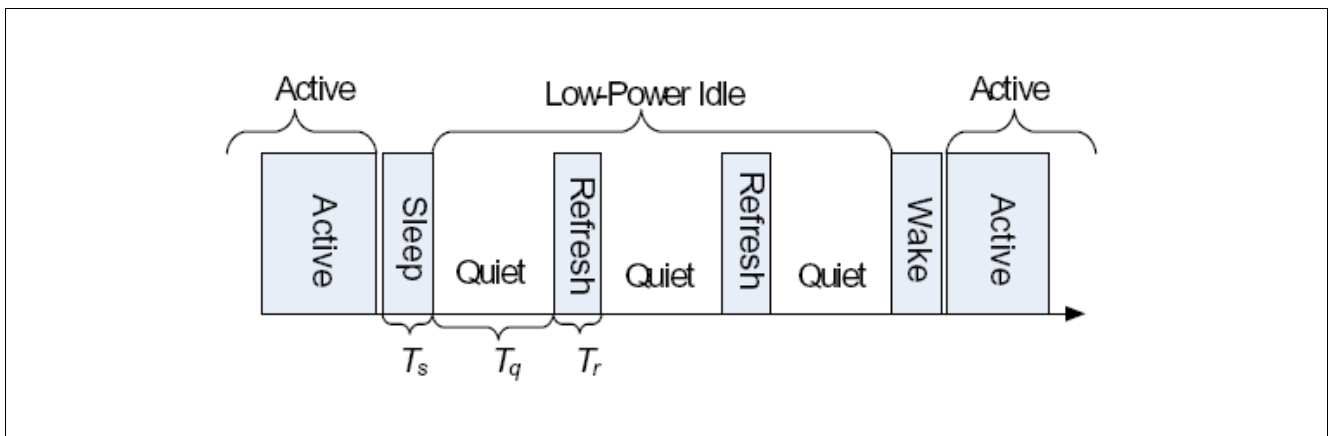

Figure 16 EEE Low Power Idle Sequence

3.13 Firmware Upgrade

The MxL86288L provides a Firmware Upgrade feature that allows feature and functional enhancements of the MxL86288L in the field.

It is possible to download a new firmware image via the MxL86288L's **MDIO Slave Interface** to a serial flash memory device connected to the MxL86288L's QSPI. The MxL86288L is then able to fetch the upgraded firmware from the flash memory after a reboot.

For Security Development Lifecycle (SDL) [10] reasons, the MxL86288L only accepts firmware images electronically signed by MaxLinear. When authentication of the flash image by the MxL86288L fails, or the download of the image is aborted or fails, the MxL86288L resets and wait for a new image to be downloaded.

In flashless mode, the host MAC SoC must transfer the MxL86288L's firmware image into the MxL86288L's on-chip memory at the MxL86288L's boot-up time. MaxLinear will provide the procedure to facilitate the firmware transfer. To upgrade the MxL86288L's firmware image, the device must be put into the reset state and restarted. This allows the usual **Power-On Sequence** to occur with the newly upgraded firmware image to be downloaded over the MDIO slave interface using a dedicated MDIO address. Once the firmware image has been transferred to the MxL86288L's on-chip memory, it is authenticated. After successfully authenticating the image, the MxL86288L continues with normal boot process. If authentication fails, or the image download fails or is aborted, the MxL86288L resets and waits for the host MAC SoC to restart the process.

The supported options for upgrading the firmware image are:

- The firmware is upgradeable over the MDIO slave interface to the flash memory device.
- Firmware download over the MDIO slave interface with MDIO address 0x1F to on-chip memory in flashless mode.
- In addition firmware download into "empty" flash is supported over MDIO slave interface.

Attention: The MDIO slave interface for firmware download or upgrade supports IEEE 802.3 Clause 22 only.

Attention: The MDIO address for firmware download or upgrade to flash is defined by the pin strapping in Table 18 with the lowest three bits equal to 0.

Attention: After the firmware upgrade to the flash memory is completed, the MxL86288L must be rebooted such that the new image is authenticated. The same requirement also applies to flash memory devices that are programmed directly by customers, which do not use the firmware upgrade procedure provided in this section.

The procedure to download firmware over the MDIO slave interface is documented in [1]. It provides information on the update/download process and which actions are required in the MAC SoC application.

Security feature to prevent flash memory wear-out due to frequent updates (flash anti-wear out) is not supported within the MxL86288L. When the system to which the MxL86288L is attached mandates such features, they must be supported by the system itself. Flash memory components typically support a minimum of 100,000 erase/program cycles, so flash wear-out is unlikely. However, ensuring a minimum interval between flash updates decreases the likelihood of wear-out. An interval of one hour sets the minimum time before wear-out to longer than 11 years. The system is also expected to ensure that the firmware is only installed when a new firmware is available and does not attempt to install a new firmware after every reboot in flash mode.

Security feature to prevent rollback of the image to a previous version (anti-rollback) is supported within the MxL86288L. The MxL86288L verifies that the new firmware has a higher or same security version number (SVN) than the previously installed firmware before executing it. If this step fails due to the firmware SVN being a lower version, the MxL86288L resets itself and waits for the host SoC to download a new image to the flash memory over the MDIO slave interface. In flashless mode, the MxL86288L resets itself and waits for the host MAC SoC to restart the firmware transfer process. If the system does not desire to have this anti-rollback feature, MaxLinear will deliver firmware images with fixed SVN, such that the security check will always pass.

4 MDIO and MMD Register Interface Description

This chapter describes the MDIO and MMD registers available to support the MxL86288L feature set. These registers are accessible by an external management entity (called STA in IEEE) to control, configure, or read the status of the MxL86288L. After power-on, the MxL86288L resets the MDIO and MMD registers to default values sufficient to operate without specific programming.

All the register definitions, behaviors, and fields are strictly compliant with IEEE 802.3. Refer to IEEE 802.3 [2] for more information about the registers. The only registers not referenced in IEEE 802.3 are two register groups that are vendor-specific: VSPEC1 and VSPEC2. These allow custom functions related to MxL86288L.

In the register descriptions, the section or table references refer to the IEEE 802.3 [2].

4.1 MDIO-specific Terminology

This list describes how the common IEEE 802.3 terms relate to MDIO and MMD register concepts discussed in this chapter.

- **STA:** Station Management. A host connected to the MDIO interface. STAs are generally Media Access Controllers (MACs). The STA drives the MDIO bus as a clock master and the MxL86288L is an MDIO slave.
- **Host:** Used as a synonym of STA in this document.
- **PHY:** Physical Layer. In the MxL86288L, this encompasses Analog Signal Processing, Digital Signal Processing, and Physical Coding Sublayer (PCS). The PHY contains several sublayers that are individually manageable entities known as MDIO manageable devices (MMDs).
- **MMD:** MDIO Manageable Device. The list of MMDs available in the MxL86288L is in [Section 4.3](#).
- **Device:** In the context of the MDIO/MMD registers, a device is a register bank grouped by logical sublayers of the PHY layer.
- **Clause:** Refers to a particular section of the IEEE 802.3 standard [2]. In particular, Clause 22 describes MDIO device 0 and Clause 45 describes the other MMDs.
- **MII:** Media Independent Interface. This encompasses the MDIO and the (G)MII as described in Clause 22. STD registers in device 0 are also called MII registers.

4.2 Register Naming and Numbering

The register numbering convention in this document is similar to that of IEEE 802.3.

The numbering syntax uses three numbers, a.b.c, as specified in IEEE 802.3, paragraph 45.1 [2], and the notation is generalized to Clause 22 registers in device 0 STD. The alphanumeric syntax also uses the same structure and uses the names of the MMD devices, registers, and register fields separated by underscores and dots.

4.2.1 Register Numbering

The syntax is as follows, with a, b, and c written as decimal numbers:

a.b.c = <DEVICE_NUMBER>.<REGISTER_NUMBER>.<FIELD_NUMBER>

When the last indicator (c) is omitted, the register numbering refers to the full register.

When a field is more than a single bit, the bit range is indicated using a colon (for example, 1:3 is the field of bits 1 to 3). In an MDIO register, the least significant bit is bit 0 and most significant bit is bit 15. All MDIO registers are 16-bit wide.

4.2.2 Register Naming

The syntax is as follows, with AA, BB, and CC written as alphanumeric strings:

AA_BB.CC = <DEVICE_NAME>.<REGISTER_NAME>.<FIELD_NAME>

When the last indicator (CC) is omitted, the register naming refers to the full register.

The fields named RES, RES1, and RES2 refer to reserved fields as per IEEE 802.3.

4.2.3 Examples

STD_STAT.ANOK is the name of the field 0.1.5, which indicates that auto-negotiation is complete.

ANEG_CTRL.ANEG_RESTART is the name of the field 7.0.9, which allows the STA to restart the Ethernet ANEG procedure.

ANEG_PHYID1 is the complete 16-bit register number 7.2, for the PHY identifier 1 number.

VSPEC1_LED1.BLINKS is the 4-bit wide field number 30.2.15:12, which contains LED1 slow blinking configuration.

4.3 MMD Devices Present in MxL86288L

The MMD devices implement groups of standardized registers under the management of the STA.

Table 27 MDIO/MMD Devices Present in MxL86288L

MDIO/MMD Name	Device Number (decimal)	Description
STD	0	MDIO Standard Device as described in Clause 22. This also contains a number of MxL86288L-specific PHY registers.
PMA/PMD	1	Control and status registers related to the PMA/PMD signal processing modules
PCS	3	Control and status registers related to the PCS encoding/decoding device
ANEG	7	Control and status registers related to the auto-negotiation device
VSPEC1	30	MxL86288L-specific LED control and other MxL86288L-specific control
VSPEC2	31	MxL86288L-specific WoL control

4.4 Responsibilities of the STA

The MxL86288L responds to all published register addresses for the device and returns a value of zero for undefined and unsupported registers.

In accordance with IEEE 802.3 guidelines, it is the responsibility of the STA entity to ensure that mutually acceptable speeds are applied consistently across all the MMDs of the MxL86288L.

The MxL86288L ignores writes to the PMA/PMD speed selection bits that select speeds not advertised in the PMA/PMD speed ability register. The PMA/PMD speed selection defaults to a supported ability.

4.5 MDIO Access Protocols to Read / Write Registers

All the MDIO/MMD registers are accessible from an external chip connected to the MDIO bus on the MDIO_S and MDC_S pins. The MxL86288L supports several MDIO frame protocols:

- Clause 22: To access Device 0
- Clause 22 Extended: To access other devices using the indirection scheme specified by IEEE 802.3
 - Dev 1: PMAPMD
 - Dev 3: PCS
 - Dev 7: ANEG
 - Dev 30: VSPEC1
 - Dev 31: VSPEC2
- Clause 45: to access all devices

Both Clause 22 Extended and Clause 45 are used to access MMD devices. However, the mechanism implemented in the MxL86288L provides faster speeds using Clause 45. It creates differences in latencies in the MDIO reply:

- The Clause 22 Extended protocol involves an indirect mechanism.
- The Clause 45 protocol provides faster replies.

The Clause 22 registers are accessed using the Clause 45 electrical interface and the Clause 22 management frame structure. Refer to IEEE 802.3 section 45 [\[2\]](#).

5 MDIO Registers Detailed Description

Table 28 Register Access Type

Mode	Symbol
Read-Only Register (Status or Ability Register)	RO
Read-Write Register (MDIO Register)	RW
Read-Write Self-Clearing Register (bit cleared after read from MDIO)	RWSC
Read-Only Self-Clearing Register (bit cleared after read from MDIO)	ROSC
Read-Only Latching Low Register	ROLL
Read-Only Latching High Register	ROLH

5.1 Standard Management Registers

This section describes the IEEE 802.3 standard management registers corresponding to Clause 22.

Table 29 Registers Overview- Standard Management Registers

Register Short Name	Register Long Name	Reset Value
STD_CTRL	STD Control (Register 0.0)	3040 _H
STD_STAT	Status Register (Register 0.1)	7949 _H
STD_PHYID1	PHY Identifier 1 (Register 0.2)	C133 _H
STD_PHYID2	PHY Identifier 2 (Register 0.3)	5400 _H ¹⁾
STD_AN_ADV	Auto-Negotiation Advertisement (Register 0.4)	9DE1 _H
STD_AN_LPA	Auto-Negotiation Link Partner Ability (Register 0.5)	1DE0 _H
STD_AN_EXP	Auto-Negotiation Expansion (Register 0.6)	0064 _H
STD_AN_NPTX	Auto-Negotiation Next Page Transmit Register (Register 0.7)	2001 _H
STD_AN_NPRX	Auto-Negotiation Link Partner Received Next Page Register (Register 0.8)	0000 _H
STD_GCTRL	Gigabit Control Register (Register 0.9)	0200 _H
STD_GSTAT	Gigabit Status Register (Register 0.10)	0000 _H
STD_MMDCTRL	MMD Access Control Register (Register 0.13)	0000 _H
STD_MMDDATA	MMD Access Data Register (Register 0.14)	0000 _H
STD_XSTAT	Extended Status Register (Register 0.15)	2000 _H

1) For the device specific reset value, see the Product and Package Naming table in the [Product Ordering Information](#) chapter.

5.1.1 Standard Management Register Descriptions

This section describes all the STD registers in detail.

STD Control (Register 0.0)

This register controls the main functions of the PHY.

IEEE Standard Register=0.0

STD_CTRL

STD Control (Register 0.0)

Reset Value

3040_H

15	14	13	12	11	10	9	8	7	6	5	0	
RST	LB	SSL	ANEN	PD	ISOL	ANRS	DPLX	COL	SSM	RES		
RWSC	RW	RW	RW	RW	RW	RWSC	RW	RW	RW	RO		

Field	Bits	Type	Description
RST	15	RWSC	<p>Reset Resets the PHY to its default state. Active links are terminated. This is a self-clearing bit, which is set to zero by the hardware after a reset is performed.</p> <p>0_B NORMAL Normal operational mode 1_B RESET Resets the device.</p>
LB	14	RW	<p>Loopback on GMII This mode enables looping back of MII data from the transmit to the receive direction. No data is transmitted to the Ethernet PHY. The device operates at the selected speed. The collision signal remains de-asserted unless otherwise forced by the collision test.</p> <p>0_B NORMAL Normal operational mode 1_B ENABLE Closes the loopback from Tx to Rx at xMII.</p>
SSL	13	RW	<p>Forced Speed Selection LSB This bit only takes effect when bit ANEN is set to zero, which disables the auto-negotiation process. This is the lower bit (LSB) of the forced speed selection and is used in conjunction with the higher bit (MSB). The standard procedure to force 2500 Mbps operation (when ANEG is disabled) is to program PMA_CTRL with 1.0.6 = 1.0.13 = 1 and 1.0.5:2 = [0 1 1 0]. The GPHY mirrors 1.0.6, 1.0.13 and 0.0.6, 0.0.13. This is the MSB LSB bit value encoding:</p> <p>00_B 10 Mbps 01_B 100 Mbps 10_B 1000 Mbps 11_B Reserved, defaults to 2500 Mbps operation when the PMA_CTRL register 1.0.5:2 equals [0 1 1 0].</p>

Field	Bits	Type	Description (cont'd)
ANEN	12	RW	Auto-Negotiation Enable Allows enabling and disabling of the auto-negotiation process capability of the PHY. When enabled, the force bits for duplex mode (CTRL.DPLX) and the speed selection (CTRL.SSM, CTRL.SSL) become inactive; otherwise, the force bits define the PHY operation. 0 _B DISABLE Disables the auto-negotiation protocol. 1 _B ENABLE Enables the auto-negotiation protocol.
PD	11	RW	Power Down Forces the device into a power down state (SLEEP) in which power consumption is the bare minimum required to still maintain the MII management interface communication. When activating the power down functionality, the PHY terminates active data links. The MII interface is also stopped in power down mode. 0 _B NORMAL Normal operational mode 1 _B POWERDOWN Forces the device into power down mode.
ISOL	10	RW	Isolate The isolation mode isolates the PHY from the MAC. The MAC interface inputs are ignored, whereas the MAC interface outputs are set to tristate (high-impedance). 0 _B NORMAL Normal operational mode 1 _B ISOLATE Isolates the PHY from the MAC.
ANRS	9	RWSC	Restart Auto-Negotiation Restarts the auto-negotiation process on the MDI. This bit does not have any effect when auto-negotiation is disabled using CTRL.ANEN. This bit is self-clearing after the auto-negotiation process is initiated. 0 _B NORMAL Stays in current mode. 1 _B RESTART Restarts auto-negotiation.
DPLX	8	RW	Forced Duplex Mode This bit only takes effect when bit CTRL.ANEN is set to zero, which disables the auto-negotiation process. This bit controls the forced duplex mode. It allows forcing of the PHY into full-duplex or half-duplex mode. This bit does not take effect in loopback mode, when bit CTRL.LB is set to 1 _B . It is only possible to force the duplex mode to half-duplex in 10BASE-T and 100BASE-TX speed modes. This field is ignored for higher speeds. 0 _B HD Half-duplex 1 _B FD Full-duplex
COL	7	RW	Collision Test Allows testing of the COL signal at the xMII interface. When the collision test is enabled, the state of the TX_EN signal is looped back to the COL signal within a minimum latency. 0 _B DISABLE Normal operational mode 1 _B ENABLE Activates the collision test.

Field	Bits	Type	Description (cont'd)
SSM	6	RW	<p>Forced Speed Selection MSB</p> <p>This bit only takes effect when bit ANEN is set to zero, which disables the auto-negotiation process. This is the higher bit (MSB) of the forced speed selection and is used in conjunction with the lower bit (LSB).</p> <p>The preferred way to force 2500 Mbps operation (when ANEG is disabled) is to program PMA_CTRL with 1.0.6 = 1.0.13 = 1 and 1.0.5:2 = [0 1 1 0].</p> <p>The GPHY mirrors 1.0.6, 1.0.13 and 0.0.6, 0.0.13.</p> <p>This is the MSB LSB bit value encoding:</p> <p>00_B 10 Mbps 01_B 100 Mbps 10_B 1000 Mbps 11_B Reserved, defaults to 2500 Mbps operation when the PMA_CTRL register 1.0.5:2 equals [0 1 1 0].</p>
RES	5:0	RO	<p>Reserved</p> <p>Write as zero, ignore on read.</p>

Status Register (Register 0.1)

This register contains status and capability information about the device. All the bits are read-only. A write access by the MAC does not have any effect. Refer to IEEE 802.3 22.2.4.2.

IEEE Standard Register=0.1

STD_STAT

Status Register (Register 0.1)

Reset Value

7949_H

15	14	13	12	11	10	9	8	7	6	5	4	3	2	1	0	
CBT4	CBTX F	CBTX H	XBTF	XBTH	CBT2F	CBT2 H	EXT	RES	MFPS	ANOK	RF	ANAB	LS	JD	XCAP	
ro	ro	ro	ro	ro	ro	ro	ro	ro	ro	ro	ro	rolh	ro	roll	rolh	ro

Field	Bits	Type	Description
CBT4	15	RO	IEEE 100BASE-T4 Specifies the 100BASE-T4 ability. 0 _B DISABLED PHY does not support this mode. 1 _B ENABLED PHY supports this mode.
CBTXF	14	RO	IEEE 100BASE-TX Full Duplex Specifies the 100BASE-TX full duplex capability. 0 _B DISABLED PHY does not support this mode. 1 _B ENABLED PHY supports this mode.
CBTXH	13	RO	IEEE 100BASE-TX Half-Duplex Specifies the 100BASE-TX half-duplex capability. 0 _B DISABLED PHY does not support this mode. 1 _B ENABLED PHY supports this mode.
XBTF	12	RO	IEEE 10BASE-T Full-Duplex Specifies the 10BASE-T full-duplex capability. 0 _B DISABLED PHY does not support this mode. 1 _B ENABLED PHY supports this mode.
XBTH	11	RO	IEEE 10BASE-T Half-Duplex Specifies the 10BASE-T half-duplex capability. 0 _B DISABLED PHY does not support this mode. 1 _B ENABLED PHY supports this mode.
CBT2F	10	RO	IEEE 100BASE-T2 Full-Duplex Specifies the 100BASE-T2 full-duplex capability. 0 _B DISABLED PHY does not support this mode. 1 _B ENABLED PHY supports this mode.
CBT2H	9	RO	IEEE 100BASE-T2 Half-Duplex Specifies the 100BASE-T2 half-duplex capability. 0 _B DISABLED PHY does not support this mode. 1 _B ENABLED PHY supports this mode.

Field	Bits	Type	Description (cont'd)
EXT	8	RO	Extended Status The extended status registers are used to specify 1000 Mbps speed capabilities in the register XSTAT. 0 _B DISABLED No extended status information available in register 15 1 _B ENABLED Extended status information available in register 15
RES	7	RO	Reserved Ignore when read.
MFPS	6	RO	Management Preamble Suppression Specifies the Management Frame (MF) preamble suppression ability. 0 _B DISABLED PHY requires management frames with preamble. 1 _B ENABLED PHY accepts management frames without preamble.
ANOK	5	RO	Auto-Negotiation Completed Indicates whether the auto-negotiation process is completed or in progress. 0 _B RUNNING Auto-negotiation process is in progress. 1 _B COMPLETED Auto-negotiation process is completed.
RF	4	ROLH	Remote Fault Indicates the detection of a remote fault event. GPHY does not indicate RF. 0 _B INACTIVE No remote fault condition detected 1 _B ACTIVE Remote fault condition detected
ANAB	3	RO	Auto-Negotiation Ability Specifies the auto-negotiation ability. 0 _B DISABLED PHY is not able to perform auto-negotiation. 1 _B ENABLED PHY is able to perform auto-negotiation.
LS	2	ROLL	Link Status Indicates the link status of the PHY to the link partner. 0 _B INACTIVE The link is down. No communication with link partner possible. 1 _B ACTIVE The link is up. Data communication with link partner is possible.
JD	1	ROLH	Jabber Detect Indicates that a jabber event was detected. 0 _B NONE No jabber condition detected 1 _B DETECTED Jabber condition detected
XCAP	0	RO	Extended Capability Indicates the availability and support of extended capability registers. 0 _B DISABLED Only base registers are supported. 1 _B ENABLED Extended capability registers are supported.

PHY Identifier 1 (Register 0.2)

This code specifies the Organizationally Unique Identifier (OUI), and the vendor's model and revision number.
IEEE Standard Register=0.2

STD_PHYID1

Reset Value

PHY Identifier 1 (Register 0.2)

C133_H

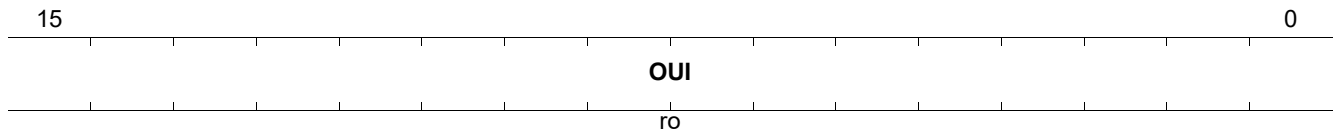

Field	Bits	Type	Description
OUI	15:0	RO	Organizationally Unique Identifier Bits 3:18

PHY Identifier 2 (Register 0.3)

IEEE Standard Register=0.3

STD_PHYID2

PHY Identifier 2 (Register 0.3)

Reset Value

5400_H

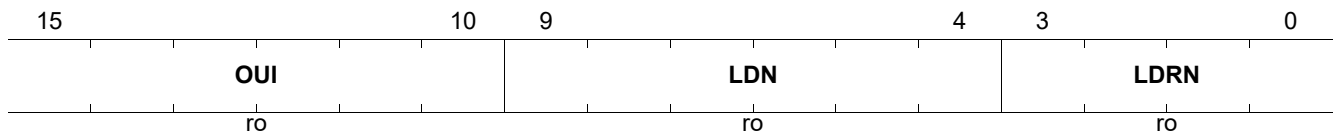

Field	Bits	Type	Description
OUI	15:10	RO	Organizationally Unique Identifier Bits 19:24
LDN	9:4	RO	Device Number Specifies the device number ¹⁾ to distinguish between several different products.
LDRN	3:0	RO	Device Revision Number Specifies the device revision number ¹⁾ to distinguish between several versions of this device.

1) For the device specific reset value, see the Product and Package Naming table in the [Product Ordering Information](#) chapter.

Auto-Negotiation Advertisement (Register 0.4)

This register contains the advertised abilities of the PHY during auto-negotiation.

IEEE Standard Register=0.4

STD_AN_ADV

Auto-Negotiation Advertisement (Register 0.4)

Reset Value

9DE1_H

15	14	13	12	11			5	4			0
NP	RES	RF	XNP				TAF				SF
rw	ro	rw	rw				rw				rw

Field	Bits	Type	Description
NP	15	RW	<p>Next Page The next page indication is encoded in bit AN_ADV.NP regardless of the selector field value or link code word encoding. The PHY always advertises NP when a 1000BASE-T mode is advertised during auto-negotiation.</p> <p>0_B INACTIVE No next page to follow 1_B ACTIVE Additional next page(s) to follow</p>
RES	14	RO	<p>Reserved Write as zero, ignore on read.</p>
RF	13	RW	<p>Remote Fault This bit allows indication of a fault to the link partner.</p> <p>0_B NONE No remote fault is indicated. 1_B FAULT A remote fault is indicated.</p>
XNP	12	RW	<p>Extended Next Page Indicates the GPHY supports transmission of extended next pages (XNP).</p> <p>0_B UNABLE GPHY is XNP unable. 1_B ABLE GPHY is XNP able.</p>
TAF	11:5	RW	<p>Technology Ability Field This is an 8-bit wide field containing information indicating supported technologies. The GPHY supports half-duplex and full-duplex 10BASE-T and 100BASE-TX and also both symmetric and asymmetric PAUSE.</p> <p>40_H PS_ASYM Advertises asymmetric pause 20_H PS_SYM Advertises symmetric pause 10_H DBT4 Advertises 100BASE-T4 08_H DBT_FDX Advertises 100BASE-TX full-duplex 04_H DBT_HDX Advertises 100BASE-TX half-duplex 02_H XBT_FDX Advertises 10BASE-T full-duplex 01_H XBT_HDX Advertises 10BASE-T half-duplex</p>

Field	Bits	Type	Description (cont'd)
SF	4:0	RW	<p>Selector Field</p> <p>This field is a 5-bit wide field for encoding 32 possible messages. The encodings are defined in IEEE 802.3-2008 Annex 28A. Unspecified combinations are reserved for future use. Reserved combinations of this field are not to be transmitted.</p> <p>00001_B IEEE802DOT3 Selects the IEEE 802.3 technology.</p>

Auto-Negotiation Link Partner Ability (Register 0.5)

IEEE Standard Register=0.5

When the auto-negotiation is complete, this register contains the advertised ability of the link partner. The bit definitions are a direct representation of the received link code word.

STD_AN_LPA
Reset Value
Auto-Negotiation Link Partner Ability (Register 0.5)
1DE0_H

15	14	13	12	11					5	4					0
NP	ACK	RF	XNP												SF
ro	ro	ro	rw												ro

Field	Bits	Type	Description
NP	15	RO	Next Page Next page request indication from the link partner. 0 _B INACTIVE No next page to follow 1 _B ACTIVE Additional next pages to follow
ACK	14	RO	Acknowledge Acknowledgment indication from the link partner's link code word. 0 _B INACTIVE The device did not receive its link partner's link code word. 1 _B ACTIVE The device received its link partner's link code word.
RF	13	RO	Remote Fault Remote fault indication from the link partner. 0 _B NONE Remote fault is not indicated by the link partner. 1 _B FAULT Remote fault is indicated by the link partner.
XNP	12	RW	Extended Next Page Indicates the GPHY supports transmission of extended next pages (XNP). 0 _B UNABLE Link partner is XNP unable. 1 _B ABLE Link partner is XNP able.
TAF	11:5	RW	Technology Ability Field 40 _H PS_ASYM Advertises asymmetric pause 20 _H PS_SYM Advertises symmetric pause 10 _H DBT4 Advertises 100BASE-T4 08 _H DBT_FDX Advertises 100BASE-TX full-duplex 04 _H DBT_HDX Advertises 100BASE-TX half-duplex 02 _H XBT_FDX Advertises 10BASE-T full-duplex 01 _H XBT_HDX Advertises 10BASE-T half-duplex
SF	4:0	RO	Selector Field 00001 _B IEEE802DOT3 Selects the IEEE 802.3 technology

Auto-Negotiation Expansion (Register 0.6)

This is the auto-negotiation expansion register indicating the status of the link partner's auto-negotiation. This register is valid only after the auto-negotiation is completed.

Refer to IEEE 802.3 28.2.4.1.5.

IEEE Standard Register=0.6

STD_AN_EXP

Auto-Negotiation Expansion (Register 0.6)

Reset Value

0064_H

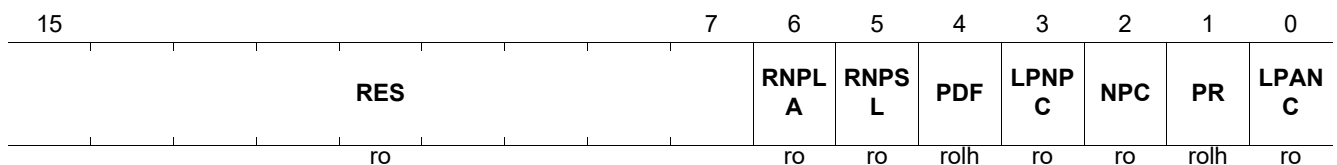

Field	Bits	Type	Description
RES	15:7	RO	Reserved Write as zero, ignore on read.
RNPLA	6	RO	Receive Next Page Location Able According to 802.3-2015, indicates the Rx NP location is indicated by field RNPSL. 0 _B UNABLE Received Next Page Storage Location is not specified by bit (6.5). 1 _B ABLE Received Next Page Storage Location is specified by bit (6.5).
RNPSL	5	RO	Receive Next Page Storage Location According to 802.3-2015, indicates the Rx NP is in register 0.8 for the GPHY. 0 _B FIVE Link partner next pages are stored in register 5. 1 _B EIGHT Link partner next pages are stored in register 8.
PDF	4	ROLH	Parallel Detection Fault 0 _B NONE A fault was not detected via the parallel detection function. 1 _B FAULT A fault was detected via the parallel detection function.
LPNPC	3	RO	Link Partner Next Page Capable 0 _B UNABLE Link partner is unable to exchange next pages. 1 _B CAPABLE Link partner is capable of exchanging next pages.
NPC	2	RO	Next Page Capable 0 _B UNABLE GPHY is unable to exchange next pages. 1 _B CAPABLE GPHY is capable of exchanging next pages.
PR	1	ROLH	Page Received 0 _B NONE A new page was not received. 1 _B RECEIVED A new page was received.
LPANPC	0	RO	Link Partner Auto-Negotiation Capable 0 _B UNABLE Link partner is unable to auto-negotiate. 1 _B CAPABLE Link partner is auto-negotiation capable.

Auto-Negotiation Next Page Transmit Register (Register 0.7)

The auto-negotiation next page transmit register contains the next page link code word to be transmitted when next page ability is supported. Refer to IEEE 802.3 28.2.4.1.6.

IEEE Standard Register=0.7

STD_AN_NPTX

Reset Value

Auto-Negotiation Next Page Transmit Register (Register 0.7)

2001_H

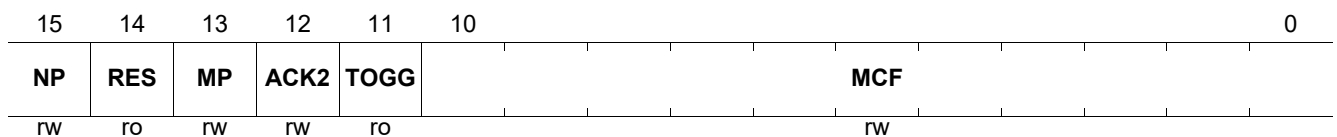

Field	Bits	Type	Description
NP	15	RW	Next Page 0 _B INACTIVE Last page 1 _B ACTIVE Additional next page(s) to follow
RES	14	RO	Reserved Write as zeros, ignore on read.
MP	13	RW	Message Page Indicates the content of MCF is either an unformatted page or a formatted message. 0 _B UNFOR Unformatted page 1 _B MESSG Message page
ACK2	12	RW	Acknowledge 2. GPHY Does Not Comply 0 _B INACTIVE Device is not able to comply with message. 1 _B ACTIVE Device complies with message.
TOGG	11	RO	Toggle This bit always takes the opposite value of the Toggle bit in the previously exchanged link code word. 0 _B ZERO Previous value of the transmitted link code word was 1 _B . 1 _B ONE Previous value of the transmitted link code word was 0 _B .

Field	Bits	Type	Description (cont'd)
MCF	10:0	RW	<p>Message or Unformatted Code Field</p> <p>When the Message Page bit is set to 1_B (0.7.13), this field is the Message Code Field of a message page used in next page exchange. The message codes are described in IEEE 802.3 Appendix 28C. It is used to indicate the type of message in UCF1 and UCF2.</p> <p>00_H Reserved 01_H Null message 02_H One Unformatted Page (UP) with TAF follows 03_H Two UPs with TAF follows 04_H Remote fault details message 05_H OUI message 06_H PHY ID message 07_H 100BASE-T2 message 08_H 1000BASE-T message 09_H MULTIGBASE-T message 0A_H EEE technology capability follows in next UP 0B_H OUI XNP</p>

Auto-Negotiation Link Partner Received Next Page Register (Register 0.8)

This register contains the next page link code word received from the link partner. Refer to IEEE 802.3-2008 28.2.4.1.7.

IEEE Standard Register=0.8

STD_AN_NPRX

Reset Value

Auto-Negotiation Link Partner Received Next Page Register (Register 0.8)

0000_H

15	14	13	12	11	10														0
NP	ACK	MP	ACK2	TOGG															MCF
ro	ro	ro	ro	ro															rw

Field	Bits	Type	Description
NP	15	RO	Next Page 0 _B INACTIVE No next pages to follow 1 _B ACTIVE Additional next page(s) to follow
ACK	14	RO	Acknowledge 0 _B INACTIVE The device did not receive its link partner's link code word. 1 _B ACTIVE The device received its link partner's link code word.
MP	13	RO	Message Page Indicates the content of MCF is either an unformatted page or a formatted message. 0 _B UNFOR Unformatted page 1 _B MESSG Message page
ACK2	12	RO	Acknowledge 2 0 _B INACTIVE Device is not able to comply with the message. 1 _B ACTIVE Device complies with the message.
TOGG	11	RO	Toggle This bit always takes the opposite value of the Toggle bit in the previously exchanged link code word. 0 _B ZERO Previous value of the transmitted link code word was 1 _B . 1 _B ONE Previous value of the transmitted link code word was 0 _B .

Field	Bits	Type	Description (cont'd)
MCF	10:0	RW	<p>Message or Unformatted Code Field</p> <p>This field is the Message Code Field of a message page used in next page exchange.</p> <p>The message codes are described in IEEE 802.3 Appendix 28C. It is used to indicate the type of message in UCF1 and UCF2.</p> <p>00_H Reserved 01_H Null message 02_H One Unformatted Page (UP) with TAF follows 03_H Two UPs with TAF follows 04_H Remote fault details message 05_H OUI message 06_H PHY ID message 07_H 100BASE-T2 message 08_H 1000BASE-T message 09_H MULTIGBASE-T message 0A_H EEE technology capability follows in next UP 0B_H OUI XNP</p>

Gigabit Control Register (Register 0.9)

This is the control register to configure the Gigabit Ethernet behavior of the PHY. Refer to IEEE 802.3-2008 40.5.1.1.

IEEE Standard Register=0.9

STD_GCTRL

Gigabit Control Register (Register 0.9)

Reset Value

0200_H

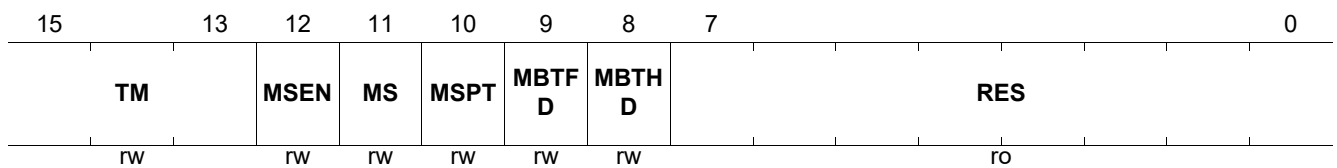

Field	Bits	Type	Description
TM	15:13	RW	Transmitter Test Mode This register field allows enabling of the standard transmitter test modes. 000 _B NOP Normal operation 001 _B WAV Test mode 1 transmit waveform test 010 _B JITM Test mode 2 transmit jitter test in master mode 011 _B JITS Test mode 3 transmit jitter test in slave mode 100 _B DIST Test mode 4 transmitter distortion test
MSEN	12	RW	Master/Slave Manual Configuration Enable 0 _B DISABLED Disables master/slave manual configuration value. 1 _B ENABLED Enables master/slave manual configuration value.
MS	11	RW	Master/Slave Configuration Value Allows forcing of master or slave mode manually when AN_GCTRL.MSEN is set to 1 _B . 0 _B SLAVE Configures PHY as slave during master/slave negotiation. 1 _B MASTER Configures PHY as master during master/slave negotiation.
MSPT	10	RW	Master/Slave Port Type Defines whether the PHY advertises itself as a multi- or single-port device, which in turn impacts the master/slave resolution function. 0 _B SPD Single-port device 1 _B MPD Multi-port device
MBTFD	9	RW	1000BASE-T Full-Duplex Advertises the 1000BASE-T full-duplex capability; always forced to 1 in converter mode. 0 _B DISABLED Advertises PHY as not 1000BASE-T full-duplex capable 1 _B ENABLED Advertises PHY as 1000BASE-T full-duplex capable

Field	Bits	Type	Description (cont'd)
MBTHD	8	RW	<p>1000BASE-T Half-Duplex Always advertises the 1000BASE-T half-duplex capability as disabled. The GPHY does not support 1000BASE-T half-duplex capability.</p> <p>0_B DISABLED Advertises PHY as not 1000BASE-T half-duplex capable</p> <p>1_B ENABLED Advertises PHY as 1000BASE-T half-duplex capable</p>
RES	7:0	RO	<p>Reserved Write as zero, ignore on read.</p>

Gigabit Status Register (Register 0.10)

This is the status register used to reflect the Gigabit Ethernet status of the PHY. Refer to IEEE 802.3-2022 40.5.1.1.

IEEE Standard Register=0.10

STD_GSTAT

Gigabit Status Register (Register 0.10)

Reset Value

0000_H

15	14	13	12	11	10	9	8	7											0
MSFA ULT	MSRE S	LRXS TAT	RRXS TAT	MBTF D	MBTH D	RES			IEC										
rwsc	ro	ro	ro	ro	ro	ro			rwsc										

Field	Bits	Type	Description
MSFAULT	15	RWSC	<p>Master/Slave Manual Configuration Fault This bit is set when the number of failed master-slave resolutions reaches 7. It is cleared upon each read of GSTAT. This bit self clears on auto-negotiation enable or auto-negotiation complete.</p> <p>0_B OK Master/slave manual configuration resolved successfully 1_B NOK Master/slave manual configuration resolved with a fault</p>
MSRES	14	RO	<p>Master/Slave Configuration Resolution 0_B SLAVE Local PHY configuration resolved to SLAVE 1_B MASTER Local PHY configuration resolved to MASTER</p>
LRXSTAT	13	RO	<p>Local Receiver Status Indicates the status of the local receiver. 0_B NOK Local receiver not OK 1_B OK Local receiver OK</p>
RRXSTAT	12	RO	<p>Remote Receiver Status Indicates the status of the remote receiver. 0_B NOK Remote receiver not OK 1_B OK Remote receiver OK</p>
MBTFD	11	RO	<p>Link Partner Capable of Operating 1000BASE-T Full-Duplex 0_B DISABLED Link partner is not capable of operating 1000BASE-T full-duplex 1_B ENABLED Link partner is capable of operating 1000BASE-T full-duplex</p>
MBTHD	10	RO	<p>Link Partner Capable of Operating 1000BASE-T Half-Duplex 0_B DISABLED Link partner is not capable of operating 1000BASE-T half-duplex 1_B ENABLED Link partner is capable of operating 1000BASE-T half-duplex</p>
RES	9:8	RO	<p>Reserved Write as zero, ignore on read.</p>

Field	Bits	Type	Description (cont'd)
IEC	7:0	RWSC	Idle Error Count Indicates the idle error count. This field contains a cumulative count of the errors detected when the receiver receives idles.

MMD Access Control Register (Register 0.13)

The MMD access control register is used in conjunction with the MMDDATA register to access the MMD register space. This uses address directing as specified in IEEE 802.3 Clause 22 Extended.

IEEE Standard Register=0.13

STD_MMDCTRL

Reset Value

MMD Access Control Register (Register 0.13)

0000_H

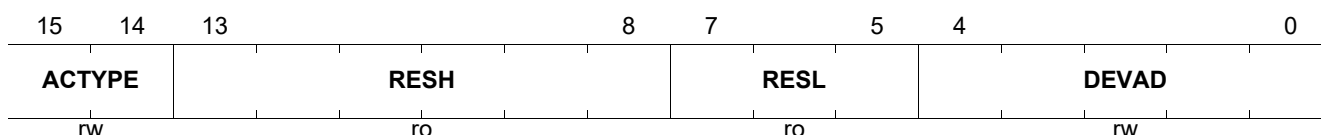

Field	Bits	Type	Description
ACTYPE	15:14	RW	Access Type Function When the MMDDATA register is accessed via an address access (ACTYPE=0), the access is directed to the address register within the MMD associated with the value in the DEVAD field. Otherwise, both the DEVAD field and the MMD address register direct the MMDDATA register data accesses to the appropriate registers within that MMD. 00 _B ADDRESS Accesses to the MMDDATA register access the MMD individual address register. 01 _B DATA Accesses to the MMDDATA register access the register within the MMD selected. 10 _B DATA_PI Accesses to the MMDDATA register access the register within the MMD selected. 11 _B DATA_PIWR Accesses to the MMDDATA register access the register within the MMD selected.
RESH	13:8	RO	Reserved Write as zero, ignored on read.
RESL	7:5	RO	Reserved Write as zero, ignored on read.
DEVAD	4:0	RW	Device Address The DEVAD field directs any accesses of register MMDDATA to the appropriate MMD as described in IEEE 802.3-2008 Clause 45.2.

MMD Access Data Register (Register 0.14)

The MMD access data register is used in conjunction with the MMD access control (MMDCTRL) register to access the MMD register space. For more information on MMD access, refer to IEEE 802.3-2008 Clause 22.2.4.3.12, Clause 45.2, and Annex 22D.

IEEE Standard Register=0.14

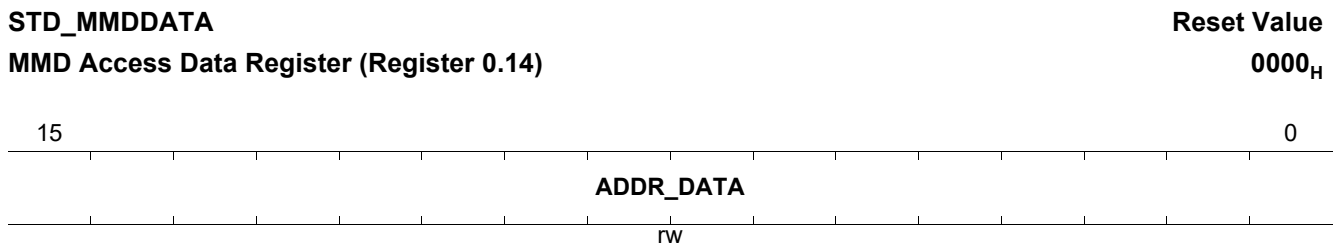

Field	Bits	Type	Description
ADDR_DATA	15:0	RW	Address or Data Register This register accesses either a specific MMD address register or the data content of the MMD register to which this address register points. The MMDCTRL register defines which function is currently valid.

Extended Status Register (Register 0.15)

This register contains extended status and capability information about the PHY. All the bits are read-only. A write access does not have any effect.

IEEE Standard Register=0.15

STD_XSTAT

Reset Value

Extended Status Register (Register 0.15)

2000_H

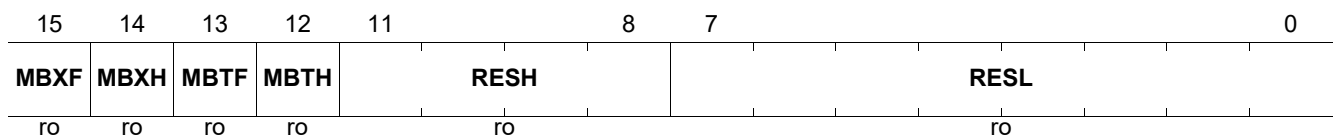

Field	Bits	Type	Description
MBXF	15	RO	1000BASE-X Full-Duplex Capability Specifies whether the PHY is capable of operating 1000BASE-X full-duplex. 0 _B DISABLED PHY does not support this mode. 1 _B ENABLED PHY supports this mode.
MBXH	14	RO	1000BASE-X Half-Duplex Capability Specifies whether the PHY is capable of operating 1000BASE-X half-duplex. 0 _B DISABLED PHY does not support this mode. 1 _B ENABLED PHY supports this mode.
MBTF	13	RO	1000BASE-T Full-Duplex Capability Specifies whether the PHY is capable of operating 1000BASE-T full-duplex. 0 _B DISABLED PHY does not support this mode. 1 _B ENABLED PHY supports this mode.
MBTH	12	RO	1000BASE-T Half-Duplex Capability GPHY do not support 1000BASE-T half-duplex capability. 0 _B DISABLED PHY does not support this mode. 1 _B ENABLED PHY supports this mode.
RESH	11:8	RO	Reserved Ignore when read.
RESL	7:0	RO	Reserved Ignore when read.

5.2 PHY-specific Management Registers

This section describes the PHY-specific management registers in device 0.

Table 30 Registers Overview- PHY-specific Management Registers

Register Short Name	Register Long Name	Reset Value
PHY_STAT1	Physical Layer Status 1 (Register 0.17)	000C _H
PHY_CTL1	Physical Layer Control 1 (Register 0.19)	0001 _H
PHY_CTL2	Physical Layer Control 2 (Register 0.20)	0006 _H
PHY_ERRCNT	Error Counter (Register 0.21)	0000 _H
PHY_MIISTAT	Media-Independent Interface Status (Register 0.24)	0000 _H
PHY_IMASK	Interrupt Mask Register (Register 0.25)	0000 _H
PHY_ISTAT	Interrupt Status Register (Register 0.26)	0000 _H
PHY_LED	LED Control Register (Register 0.27)	FF00 _H
PHY_TPGCTRL	Test-Packet Generator Control (Register 0.28)	0000 _H
PHY_TPGDATA	Test-Packet Generator Data (Register 0.29)	00AA _H
PHY_FWV	Firmware Version Register (Register 0.30)	0000 _H

5.2.1 PHY-specific Management Register Descriptions

This section describes all the PHY registers in detail.

Physical Layer Status 1 (Register 0.17)

This register reports PHY link information, for example link-up, polarity reversals, and port mapping. The content of this register is only valid when the link is up.

IEEE Standard Register=0.17

PHY_STAT1

Physical Layer Status 1 (Register 0.17)

Reset Value

000C_H

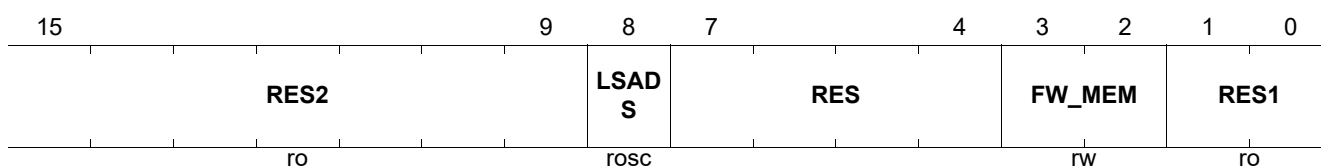

Field	Bits	Type	Description
RES2	15:9	RO	Reserved Write as zero, ignored on read.
LSADS	8	ROSC	Link Speed Auto-Downspeed Status Monitors the status of the Auto-Downspeed (ADS). 0 _B NORMAL Did not perform any link speed ADS. 1 _B DETECTED Detected an ADS.
FW_MEM	3:2	RW	Firmware Memory Location Indicates memory target used for firmware execution. 11 _B RAM Firmware is executed from SRAM. Others: Reserved.
RES1	1:0	RO	Reserved Write as zero, ignored on read.

Physical Layer Control 1 (Register 0.19)

This register controls the PHY functions.

IEEE Standard Register=0.19

PHY_CTL1

Reset Value

Physical Layer Control 1 (Register 0.19)

0001_H

15	13	12	11	8	7	6	5	4	3	2	1	0	
TLOOP		TXOFF	TXADJ			POLD	POLC	POLB	POLA	MDIC D	MDIA B	RES	AMDIX
rw		rw	rw			rw	rw	rw	rw	rw	rw	ro	rw

Field	Bits	Type	Description
TLOOP	15:13	RW	Test Loop Configures predefined test loops. 000 _B OFF Test loops are switched off - normal operation. 001 _B NETL Near-end test loop 010 _B FETL Far-end test loop. 100 _B RJTL RJ45 connector test loop. 101 _B FETL S Standalone far-end test loop. No dependency on GMII_TX_CLK and GMII_RX_CLK. Others: Reserved.
TXOFF	12	RW	Transmitter Off This register bit turns the transmitter off. This feature is used for return loss measurements. 0 _B ON Transmitter is on. 1 _B OFF Transmitter is off.
TXADJ	11:8	RW	Transmit Level Adjustment Reserved.
POLD	7	RW	Polarity Inversion Control on Port D 0 _B NORMAL Polarity normal 1 _B INVERTED Polarity inversion
POLC	6	RW	Polarity Inversion Control on Port C 0 _B NORMAL Polarity normal 1 _B INVERTED Polarity inversion
POLB	5	RW	Polarity Inversion Control on Port B 0 _B NORMAL Polarity normal 1 _B INVERTED Polarity inversion
POLA	4	RW	Polarity Inversion Control on Port A 0 _B NORMAL Polarity normal 1 _B INVERTED Polarity inversion
MDICD	3	RW	Mapping of MDI Ports C and D Used when Auto-MDIX is OFF to force the MDIX cable crossover configuration. 0 _B MDI Normal MDI mode 1 _B MDIX Crossover MDI-X mode

Field	Bits	Type	Description (cont'd)
MDIAB	2	RW	Mapping of MDI Ports A and B Used when Auto-MDIX is OFF to force the MDIX cable crossover configuration. 0 _B MDI Normal MDI mode 1 _B MDIX Crossover MDI-X mode
RES	1	RO	Reserved
AMDIX	0	RW	PHY Performs Auto-MDI/MDI-X or Uses Manual MDI/MDI-X 0 _B MANUAL PHY uses manual MDI/MDI-X. 1 _B AUTO PHY performs Auto-MDI/MDI-X.

Physical Layer Control 2 (Register 0.20)

This register controls the PHY functions.

IEEE Standard Register=0.20

PHY_CTL2
Physical Layer Control 2 (Register 0.20)
Reset Value
0006_H

15	10	9	8	7	5	4	3	2	1	0
RES		SDET P	STICKY Y	RES1		RES2	LP	PSCL	ANPD	LPI
		rw	rw	ro		rw	rw	rw	rw	rw

Field	Bits	Type	Description
SDETP	9	RW	Signal Detection Polarity for the 1000BASE-X PHY This field is reserved because 1000BASE-X is not supported on this PHY port.
STICKY	8	RW	Sticky-Bit Handling Setting this bit to 1 _B ensures that all the vendor specific registers (of type RW) in the PHY (device 0), VSPEC1 (device 30), and VSPEC2 (device 31) are not changed during a MDIO reset or software reset of the GPHY. This allows the STA to keep the configurations chosen before reset. 0 _B OFF Sticky-bit handling is disabled. 1 _B ON Sticky-bit handling is enabled.
RES1	7:5	RO	Reserved Write as zero, ignored on read.
RES2	4	RW	Reserved
LP	3	RW	Low Power Mode Low Power Mode (LP) allows the GPHY to save energy by disabling most of the digital logic to reduce power consumption to its lowest level. The entry to LP is triggered when the PHY does not sense any energy on the cable and no link pulses (NLP, FLP, Beacons) are received. After spending VSPEC1_NBT_DS_CTRL.NRG_RST_CNT without energy in the ABILITY_DETECT state defined by IEEE 802.3 Clause 28, and after the timer defined VSPEC1_LOW_POWER_ENTRY_TIME.LPE_TIM expired, the PHY enters LP. 0 _B OFF LP is disabled. The GPHY does not enter LP. 1 _B ON LP is enabled. The GPHY enters LP when no energy is sensed.
PSCL	2	RW	Power Consumption Scaling Depending on Link Quality Allows enabling/disabling of the power consumption scaling depending on the link quality. 0 _B OFF PSCL is disabled. 1 _B ON PSCL is enabled.

Field	Bits	Type	Description (cont'd)
ANPD	1	RW	<p>Auto-Negotiation Power Down Allows enabling/disabling of the power down modes during auto-negotiation looking for a link partner.</p> <p>0_B OFF ANPD is disabled. 1_B ON ANPD is enabled.</p>
LPI	0	RW	<p>Assert LPI via MDIO Controls assertion/de-assertion of the LPI by the MDIO instead of following the (X)GMII LPI. Used to force the EEE on the TPI (ignoring the LPI indication from MAC).</p> <p>0_B DE-ASSERT LPI is de-asserted on TPI. 1_B ASSERT LPI is asserted on TPI.</p>

Error Counter (Register 0.21)

This register controls the error counter. It allows the number of errors detected in the PHY to be counted for monitoring purposes.

IEEE Standard Register=0.21

PHY_ERRCNT

Reset Value

Error Counter (Register 0.21)

0000_H

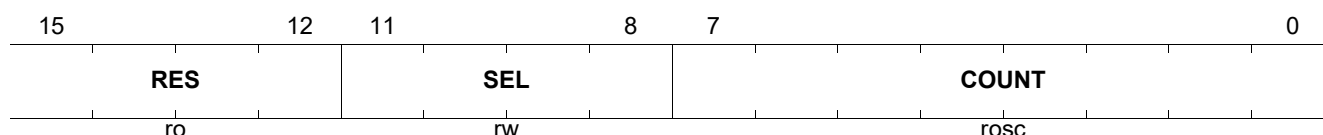

Field	Bits	Type	Description
RES	15:12	RO	Reserved Write as zero, ignored on read.
SEL	11:8	RW	Select Error Event Configures which error type the error counter counts: 0000 _B RXERR Receive errors are counted. 0001 _B RXACT Receive frames are counted. 0010 _B ESDERR ESD errors are counted. 0011 _B SSDERR SSD errors are counted. 0100 _B TXERR Transmit errors are counted. 0101 _B TXACT Transmit frames events are counted. 0110 _B COL Collision events are counted. 1000 _B NLD Number of Link Down events are counted. 1001 _B NDS Number of ADS events are counted. 1010 _B RES Reserved 1011 _B RES Reserved
COUNT	7:0	ROSC	Counter Value This counter value is updated each time the selected error event is detected. The counter value is reset every time a read operation on this register is performed or the error event is changed. The counter saturates at value FF _H .

Media-Independent Interface Status (Register 0.24)

This register contains status information on the Ethernet link, concatenated in a single register to allow concise status read by the STA in a single register.

IEEE Standard Register=0.24

PHY_MIISTAT

Reset Value

Media-Independent Interface Status (Register 0.24)

0000_H

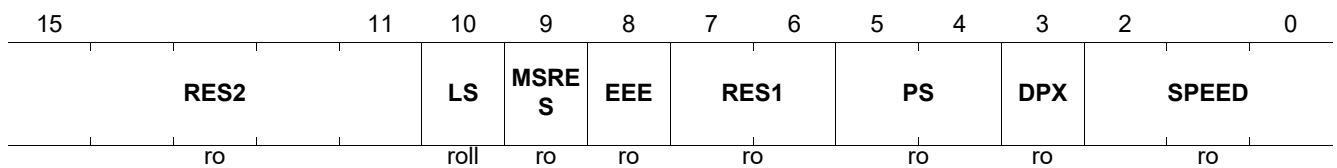

Field	Bits	Type	Description
RES2	15:11	RO	Reserved Write as zero, ignored on read.
LS	10	ROLL	Link Status of GPHY Ethernet PHY Operation Indicates the link status of the PHY. 0 _B INACTIVE The link is down. No communication with link partner possible. 1 _B ACTIVE The link is up. Data communication with link partner is possible.
MSRES	9	RO	Master/Slave Configuration Indicates the master/slave configuration 0 _B SLAVE Local PHY configuration is SLAVE after ANEG. 1 _B MASTER Local PHY configuration is MASTER after ANEG.
EEE	8	RO	Energy-Efficient Ethernet Mode 0 _B OFF EEE is disabled after ANEG resolution. 1 _B ON EEE is enabled after ANEG resolution.
RES1	7:6	RO	Reserved
PS	5:4	RO	Pause Status for Flow Control 00 _B NONE No PAUSE 01 _B TX Transmit PAUSE 10 _B RX Receive PAUSE 11 _B TXRX Both transmit and receive PAUSE
DPX	3	RO	GPHY Ethernet PHY Duplex Mode 0 _B HDX Half-duplex 1 _B FDX Full-duplex
SPEED	2:0	RO	GPHY Ethernet PHY Speed 000 _B TEN 10 Mbps 001 _B FAST 100 Mbps 010 _B GIGA 1000 Mbps 011 _B ANEG Auto-negotiation mode 100 _B BZZG5 2.5 Gbps

Interrupt Mask Register (Register 0.25)

This register defines the mask for the Interrupt Status Register (ISTAT), which contains the event source for the MDINT interrupt sent from the GPHY to an external chip.

The information about the interrupt source is indicated in the ISTAT register.

IEEE Standard Register=0.25

PHY_IMASK

Reset Value

Interrupt Mask Register (Register 0.25)

0000_H

15	14	13	12	11	10	9	8	7	6	5	4	3	2	1	0
WOL	MSRE	NPRX	NPTX	ANE	ANC	RES	RES	LP	TEMP	ADSC	MDIPC	MDIXC	DXMC	LSPC	LSTC
RW	RW	RW	RW	RW	RW	RW	RW	RW	RW	RW	RW	RW	RW	RW	RW

Field	Bits	Type	Description
WOL	15	RW	Wake-on-LAN Event Mask When active and masked in IMASK, the MDINT is activated upon detection of a valid WoL event. 0 _B INACTIVE Interrupt is masked out. 1 _B ACTIVE Interrupt is activated.
MSRE	14	RW	Master/Slave Resolution Error Mask When active, MDINT is activated upon detection of a master/slave resolution error (MSRE) during a 1000BASE-T ANEG. 0 _B INACTIVE Interrupt is masked out. 1 _B ACTIVE Interrupt is activated.
NPRX	13	RW	Next Page Received Mask When active, MDINT is activated upon reception of a next page in STD_AN_NPRX. 0 _B INACTIVE Interrupt is masked out. 1 _B ACTIVE Interrupt is activated.
NPTX	12	RW	Next Page Transmitted Mask When active, MDINT is activated upon transmission of the currently stored next page in STD_AN_NPTX. 0 _B INACTIVE Interrupt is masked out. 1 _B ACTIVE Interrupt is activated.
ANE	11	RW	Auto-Negotiation Error Mask When active, MDINT is activated upon detection of an ANEG error. 0 _B INACTIVE Interrupt is masked out. 1 _B ACTIVE Interrupt is activated.
ANC	10	RW	Auto-Negotiation Complete Mask When active, MDINT is activated upon completion of the ANEG process. 0 _B INACTIVE Interrupt is masked out. 1 _B ACTIVE Interrupt is activated.

Field	Bits	Type	Description (cont'd)
LP	7	RW	<p>LP Entry Indication Mask</p> <p>0_B INACTIVE Interrupt is masked out. The STA does not need to be informed of the event.</p> <p>1_B ACTIVE Interrupt is activated. The STA receives MDINT when the PHY is about to enter LP.</p>
TEMP	6	RW	<p>TEMP</p> <p>0_B INACTIVE Interrupt is masked out. The STA does not need to be informed of the event.</p> <p>1_B ACTIVE Interrupt is activated. The interrupt is triggered when the temperature goes beyond the normal operating range.</p>
ADSC	5	RW	<p>Link Speed Auto-Downspeed Detect Mask</p> <p>When active, MDINT is activated upon detection of a link speed ADS event.</p> <p>0_B INACTIVE Interrupt is masked out.</p> <p>1_B ACTIVE Interrupt is activated.</p>
MDIPC	4	RW	<p>MDI Polarity Change Detect Mask</p> <p>When active, MDINT is activated upon detection of an MDI polarity change event.</p> <p>0_B INACTIVE Interrupt is masked out.</p> <p>1_B ACTIVE Interrupt is activated.</p>
MDIXC	3	RW	<p>MDIX Change Detect Mask</p> <p>When active, MDINT is activated upon detection of an MDI/MDIX cross-over change event.</p> <p>0_B INACTIVE Interrupt is masked out.</p> <p>1_B ACTIVE Interrupt is activated.</p>
DXMC	2	RW	<p>Duplex Mode Change Mask</p> <p>When active, MDINT is activated upon detection of full or half-duplex change.</p> <p>0_B INACTIVE Interrupt is masked out.</p> <p>1_B ACTIVE Interrupt is activated.</p>
LSPC	1	RW	<p>Link Speed Change Mask</p> <p>When active, MDINT is activated upon detection of link speed change.</p> <p>0_B INACTIVE Interrupt is masked out.</p> <p>1_B ACTIVE Interrupt is activated.</p>
LSTC	0	RW	<p>Link State Change Mask</p> <p>When active, MDINT is activated upon detection of link status change.</p> <p>0_B INACTIVE Interrupt is masked out.</p> <p>1_B ACTIVE Interrupt is activated.</p>

Interrupt Status Register (Register 0.26)

This register defines the event source for the MDINT interrupt sent from the GPHY to an external chip.

PHY_ISTAT is a cleared on read by the STA.

IEEE Standard Register=0.26

PHY_ISTAT

Interrupt Status Register (Register 0.26)

Reset Value

0000_H

15	14	13	12	11	10	9	8	7	6	5	4	3	2	1	0
WOL	MSRE	NPRX	NPTX	ANE	ANC	RES	RES	LP	TEMP	ADSC	MDIPC	MDIXC	DXMC	LSPC	LSTC
ROSC	ROSC	ROSC	ROSC	ROSC	ROSC	ROSC	ROSC	ROSC	ROSC	ROSC	ROSC	ROSC	ROSC	ROSC	ROSC

Field	Bits	Type	Description
WOL	15	ROSC	Wake-on-LAN Interrupt Status When this bit is set, the MDINT is activated upon detection of a valid WoL event. 0 _B INACTIVE This event is not the interrupt source. 1 _B ACTIVE The WoL event is the source of the interrupt.
MSRE	14	ROSC	Master/Slave Resolution Error Interrupt Status When this bit is set, the MDINT is activated upon detection of a MSRE during a 1000BASE-T ANEG. 0 _B INACTIVE This event is not the interrupt source. 1 _B ACTIVE The MSRE event is the source of the interrupt.
NPRX	13	ROSC	Next Page Received Interrupt Status When this bit is set, the MDINT is activated upon reception of a next page in STD_AN_NPRX. 0 _B INACTIVE This event is not the interrupt source. 1 _B ACTIVE The NPRX event is the source of the interrupt.
NPTX	12	ROSC	Next Page Transmitted Interrupt Status When this bit is set, the MDINT is activated upon transmission of the currently stored next page in STD_AN_NPTX. 0 _B INACTIVE This event is not the interrupt source. 1 _B ACTIVE The NPTX event is the source of the interrupt.
ANE	11	ROSC	Auto-Negotiation Error Interrupt Status When this bit is set, the MDINT is activated upon detection of an ANEG error. 0 _B INACTIVE This event is not the interrupt source. 1 _B ACTIVE The ANEG error event is the source of the interrupt.
ANC	10	ROSC	Auto-Negotiation Complete Interrupt Status When this bit is set, the MDINT is activated upon completion of the ANEG process. 0 _B INACTIVE This event is not the interrupt source. 1 _B ACTIVE The ANEG complete event is the source of the interrupt.

Field	Bits	Type	Description (cont'd)
LP	7	ROSC	<p>LP Entry Indication</p> <p>0_B INACTIVE No indication of LP entry</p> <p>1_B ACTIVE Indication of LP entry.</p>
TEMP	6	ROSC	<p>TEMP</p> <p>Indicates that thermal mitigation action must be taken when the temperature goes beyond the normal operating range. The GPHY implements ADS by default when this happens, but it is possible to disable ADS. When the SoC disables ADS, it is recommended that the SoC initiates a link down and changes the speed capability to cool the device back to the normal temperature range. When the temperature reaches the maximum absolute rating, the device resets for safety purposes. Thermal mitigation must ensure that the maximum absolute temperature limits are never reached.</p> <p>0_B INACTIVE This event is not the interrupt source.</p> <p>1_B ACTIVE The TEMP change event is the source of the interrupt.</p>
ADSC	5	ROSC	<p>Link Speed Auto-Downspeed Detect Interrupt Status</p> <p>When this bit is set, the MDINT is activated upon detection of a link speed ADS event.</p> <p>0_B INACTIVE This event is not the interrupt source.</p> <p>1_B ACTIVE The ADSC change event is the source of the interrupt.</p>
MDIPC	4	ROSC	<p>MDI Polarity Change Detect Interrupt Status</p> <p>When this bit is set, the MDINT is activated upon detection of an MDI polarity change event.</p> <p>0_B INACTIVE This event is not the interrupt source.</p> <p>1_B ACTIVE The MDIPC change event is the source of the interrupt.</p>
MDIXC	3	ROSC	<p>MDIX Change Detect Interrupt Status</p> <p>When this bit is set, the MDINT is activated upon detection of an MDI/MDIX cross-over change event.</p> <p>0_B INACTIVE This event is not the interrupt source.</p> <p>1_B ACTIVE The MDIX change event is the source of the interrupt.</p>
DXMC	2	ROSC	<p>Duplex Mode Change Interrupt Status</p> <p>When this bit is set, the MDINT is activated upon detection of a full or half-duplex change.</p> <p>0_B INACTIVE This event is not the interrupt source.</p> <p>1_B ACTIVE The DXMC change event is the source of the interrupt.</p>
LSPC	1	ROSC	<p>Link Speed Change Interrupt Status</p> <p>When this bit is set, the MDINT is activated upon detection of link speed change.</p> <p>0_B INACTIVE This event is not the interrupt source.</p> <p>1_B ACTIVE The LSPC change event is the source of the interrupt.</p>
LSTC	0	ROSC	<p>Link State Change Interrupt Status</p> <p>When this bit is set, the MDINT is activated upon detection of link status change.</p> <p>0_B INACTIVE This event is not the interrupt source.</p> <p>1_B ACTIVE The LSTC change event is the source of the interrupt.</p>

LED Control Register (Register 0.27)

This register contains the control bits for direct access to the LEDs by setting the on/off LEDxDA bits (where x is from 0 to 2).

To directly control the LED, the integrated LED functions must be disabled by the LEDxEN bit in this register.

The integrated LED functions are specified in the more sophisticated LED control registers in the MMD device VSPEC1.

IEEE Standard Register=0.27

PHY_LED
Reset Value
LED Control Register (Register 0.27)
FF00_H

15	12	11	10	9	8	7	4	3	2	1	0	
RES			RES	LED2EN	LED1EN	LED0EN	RES1		RES	LED2DA	LED1DA	LED0DA
rw			rw	rw	rw	rw	ro		rw	rw	rw	rw

Field	Bits	Type	Description
RES	15:12	RW	Reserved The default value must not be changed.
LED2EN	10	RW	Enable Integrated Function of LED2 Write a 0 to this bit to disable the pre-configured integrated function for this LED. The LED remains off unless directly accessed via LED2DA. 0 _B DISABLE Disables the integrated LED function. 1 _B ENABLE Enables the integrated LED function.
LED1EN	9	RW	Enable Integrated Function of LED1 Write a 0 to this bit to disable the pre-configured integrated function for this LED. The LED remains off unless directly accessed via LED1DA. 0 _B DISABLE Disables the integrated LED function. 1 _B ENABLE Enables the integrated LED function.
LED0EN	8	RW	Enable Integrated Function of LED0 Write a 0 to this bit to disable the pre-configured integrated function for this LED. The LED remains off unless directly accessed via LED0DA. 0 _B DISABLE Disables the integrated LED function. 1 _B ENABLE Enables the integrated LED function.
RES1	7:4	RO	Reserved Write as zero, ignored on read.
LED2DA	2	RW	Direct Access to LED2 Write a 1 to this bit to illuminate the LED. LED2EN must be set to zero. 0 _B OFF Switch off the LED. 1 _B ON Switch on the LED.
LED1DA	1	RW	Direct Access to LED1 Write a 1 to this bit to illuminate the LED. LED1EN must be set to zero. 0 _B OFF Switch off the LED. 1 _B ON Switch on the LED.

Field	Bits	Type	Description (cont'd)
LED0DA	0	RW	Direct Access to LED0 Write a 1 to this bit to illuminate the LED. LED0EN must be set to zero. 0 _B OFF Switch off the LED. 1 _B ON Switch on the LED.

Test-Packet Generator Control (Register 0.28)

This register controls the operation of the integrated Test-Packet Generator (TPG). This module is only used for testing purposes.

IEEE Standard Register=0.28

PHY_TPGCTRL
Reset Value
Test-Packet Generator Control (Register 0.28)
0000_H

15	14	13	12	11	10	9	8	7	6	4	3	2	1	0
RES		MODE	RES3	IPGL		TYPE		RES2	SIZE			RES1	STAR T	EN
rw		rw	ro	rw		rw		ro	rw			ro	rw	rw

Field	Bits	Type	Description
RES	15:14	RW	Reserved Write as zero, ignore on read.
MODE	13	RW	TPG Mode Configures the packet generation mode. 0 _B CONTINUOUS Sends packets continuously. 1 _B SINGLE Sends a single packet.
RES3	12	RO	Reserved Write as zero, ignore on read.
IPGL	11:10	RW	Inter-Packet Gap Length Configures the length of the inter-packet gap in bit times. 00 _B RES Reserved 01 _B BT96 Length is 96 bit times 10 _B BT960 Length is 960 bit times 11 _B BT9600 Length is 9600 bit times
TYPE	9:8	RW	Packet Data Type Configures the packet data type to be either predefined, byte increment, or random. When predefined, the content of the register TPGDATA is used. 00 _B RANDOM Uses random data as the packet content. 01 _B BYTEINC Uses byte increment as the packet content. 10 _B PREDEF Uses predefined content of the register TPGDATA. 11 _B RES Reserved.
RES2	7	RO	Reserved. Write as zero, ignore on read.

Field	Bits	Type	Description (cont'd)
SIZE	6:4	RW	<p>Packet Size Configures the size of the generated Ethernet packets in bytes. The size includes DA, SA, length/type, payload, and FCS.</p> <p>000_B B64 Packet length is 64 bytes 001_B B2048 Packet length is 2048 bytes 010_B B256 Packet length is 256 bytes 011_B B4096 Packet length is 4096 bytes 100_B B1024 Packet length is 1024 bytes 101_B B1518 Packet length is 1518 bytes 110_B B9000 Packet length is 9000 bytes</p>
RES1	3:2	RO	<p>Reserved Write as zero, ignore on read.</p>
START	1	RW	<p>Start or Stop TPG Data Generation. Starts the TPG data generation. Depending on the MODE, the TPG sends only one packet or chunks of 10000 packets until stopped.</p> <p>0_B STOP Stops the TPG data generation. 1_B START Starts the TPG data generation.</p>
EN	0	RW	<p>Enable the TPG Enables the TPG for data generation.</p> <p>0_B DISABLE Disables the TPG 1_B ENABLE Enables the TPG</p>

Test-Packet Generator Data (Register 0.29)

Specifies the payload data to be used when sending a non-random data packet. All payload data bytes are sent with this value.

IEEE Standard Register=0.29

PHY_TPGDATA

Reset Value

Test-Packet Generator Data (Register 0.29)

00AA_H

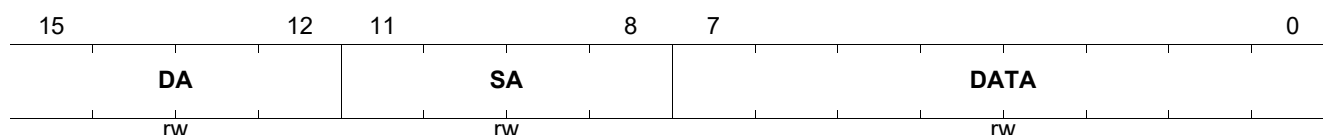

Field	Bits	Type	Description
DA	15:12	RW	Destination Address Configures the destination address nibble. The destination address builds up to 00-03-19-FF-FF-F[DA].
SA	11:8	RW	Source Address Configures the source address nibble. The source address builds up to 00-03-19-FF-FF-F[SA].
DATA	7:0	RW	Data Byte to be Transmitted This is the content of the payload bytes in the frame to send constant data. The bit masks are shown here. For configuration details, refer to the corresponding chapter. 80 _H PREC Selects whether to take full precision (1) or reduced precision (0) at bit 7 60 _H PREC2 For reduced precision, selects the options with bits [6:5] 10 _H RESERVED Reserved

Firmware Version Register (Register 0.30)

This register contains the version of the PHY firmware. The firmware initializes the version number at boot time with its current software version. This register is read-only by the external STA.

IEEE Standard Register=0.30

PHY_FWV

Reset Value

Firmware Version Register (Register 0.30)

0000_H

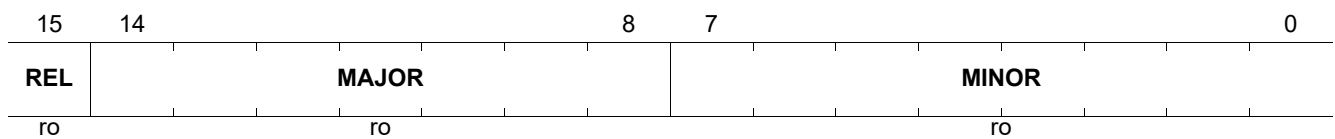

Field	Bits	Type	Description
REL	15	RO	Release Indication This parameter indicates either a test or a release version. 0 _B TEST Indicates a test version. 1 _B RELEASE Indicates a released version.
MAJOR	14:8	RO	Major Version Number Specifies the main version release number of the firmware.
MINOR	7:0	RO	Minor Version Number Specifies the sub-version release number of the firmware.

6 MMD Registers Detailed Description

Table 31 Register Access Type

Mode	Symbol
Status Register (Status or Ability Register)	RO
Read-Write Register (MDIO Register)	RW
Read-Write Self-Clearing Register (bit is cleared after read from MDIO)	RWSC
Read-Only Self-Clearing Register (bit is cleared after read from MDIO)	ROSC

6.1 Standard PMAPMD Registers for MMD=0x01

Table 32 Registers Overview- Standard PMAPMD Registers

Register Short Name	Register Long Name	Reset Value
PMA_CTRL1	PMA/PMD Control 1 (Register 1.0)	2058 _H
PMA_STAT1	PMA/PMD Status 1 (Register 1.1)	0000 _H
PMA_DEVID1	PHY Identifier 1 (Register 1.2)	C133 _H
PMA_DEVID2	PHY Identifier 2 (Register 1.3)	5400 _H ¹⁾
PMA_SPEED_ABILITY	PMA/PMD Speed Ability (Register 1.4)	2070 _H
PMA_DIP1	Devices in Package 1 (Register 1.5)	008B _H
PMA_DIP2	Devices in Package 2 (Register 1.6)	C000 _H
PMA_CTL2	PMA/PMD Control 2 (Register 1.7)	0030 _H
PMA_STAT2	PMA/PMD Status 2 (Register 1.8)	8200 _H
PMA_EXT_ABILITY	PMA/PMD Extended Ability (Register 1.11)	41A0 _H
PMA_PACKID1	AN Package Identifier (Register 1.14)	C133 _H
PMA_PACKID2	AN Package Identifier (Register 1.15)	5400 _H ¹⁾
PMA_MGBT_EXTAB	PMAPMD Extended Ability (Register 1.21)	0001 _H
PMA_MGBT_STAT	MULTIGBASE-T Status (Register 1.129)	0000 _H
PMA_MGBT_POLARITY	MULTIGBASE-T Pair Swap and Polarity (Register 1.130)	0003 _H
PMA_MGBT_TX_PBO	MULTIGBASE-T Tx Power Backoff and PHY Short Reach Setting (Register 1.131)	0000 _H
PMA_MGBT_TEST_MODE	MULTIGBASE-T Test Mode (Register 1.132)	0000 _H
PMA_MGBT_SNR_OPMARGIN_A	MULTIGBASE-T SNR Margin Channel A (Register 1.133)	0000 _H
PMA_MGBT_SNR_OPMARGIN_B	MULTIGBASE-T SNR Margin Channel B (Register 1.134)	0000 _H
PMA_MGBT_SNR_OPMARGIN_C	MULTIGBASE-T SNR Margin Channel C (Register 1.135)	0000 _H
PMA_MGBT_SNR_OPMARGIN_D	MULTIGBASE-T SNR Margin Channel D (Register 1.136)	0000 _H
PMA_MGBT_MINMARGIN_A	MULTIGBASE-T SNR Minimum Margin Channel A (Register 1.137)	0000 _H
PMA_MGBT_MINMARGIN_B	MULTIGBASE-T SNR Minimum Margin Channel B (Register 1.138)	0000 _H
PMA_MGBT_MINMARGIN_C	MULTIGBASE-T SNR Minimum Margin Chan C (Register 1.139)	0000 _H
PMA_MGBT_MINMARGIN_D	MULTIGBASE-T SNR Minimum Margin Chan D (Register 1.140)	0000 _H
PMA_MGBT_POWER_A	MULTIGBASE-T Rx Power Channel A (Register 1.141)	0000 _H
PMA_MGBT_POWER_B	MULTIGBASE-T Rx Power Channel B (Register 1.142)	0000 _H
PMA_MGBT_POWER_C	MULTIGBASE-T Rx Power Chan C (Register 1.143)	0000 _H
PMA_MGBT_POWER_D	MULTIGBASE-T Rx Power Chan D (Register 1.144)	0000 _H
PMA_MGBT_SKEW_DELAY_0	MULTIGBASE-T Skew Delay 0 (Register 1.145)	0000 _H
PMA_MGBT_SKEW_DELAY_1	MULTIGBASE-T Skew Delay 1 (Register 1.146)	0000 _H

Table 32 Registers Overview- Standard PMAPMD Registers (cont'd)

Register Short Name	Register Long Name	Reset Value
PMA_MGBT_FAST_RETRAIN_STA_CTRL	MULTIGBASE-T Skew Delay 2 (Register 1.147)	0010 _H
PMA_TIMESYNC_CAP	PMA TimeSync Capability Indication (Register 1.1800)	0000 _H

1) For the device specific reset value, see the Product and Package Naming table in the [Product Ordering Information](#) chapter.

6.1.1 PMAPMD Register Descriptions

This section describes all the PMAPMD registers in detail.

PMA/PMD Control 1 (Register 1.0)

IEEE Standard Register=1.0

PMA_CTRL1

PMA/PMD Control 1 (Register 1.0)

Reset Value

2058_H

15	14	13	12	11	10	7	6	5	2	1	0
RST	RES	SSL	RES	LOW_POWER*		RES	SSM		SPEED_SEL	NS1	NS2
RW		RW		RW			RW		RW	RO	RO

Field	Bits	Type	Description
RST	15	RW	Reset 0 _B Normal operation 1 _B PMA/PMD reset
SSL	13	RW	Speed Selection (LSB) Used in conjunction with field SPEED_SEL_MSB. MSB LSB: 00 _B 10 Mbps 01 _B 100 Mbps 10 _B 1000 Mbps 11 _B Bits [5:2] select the speed (SPEED_SEL field)
LOW_POWER	11	RW	Low Power 0 _B Normal operation 1 _B Enters low power mode.
SSM	6	RW	Speed Selection (MSB) Used in conjunction with field SPEED_SEL_LSB. MSB LSB: 00 _B 10 Mbps 01 _B 100 Mbps 10 _B 1000 Mbps 11 _B Bits [5:2] select the speed (SPEED_SEL field)
SPEED_SEL	5:2	RW	Speed Selection Bit usage (from bit 5 to bit 2): 0 0 0 0 _B Not supported. The speed defaults to 2.5 Gbps. 0 0 0 1 _B Not supported. The speed defaults to 2.5 Gbps. 0 0 1 0 _B Not supported. The speed defaults to 2.5 Gbps. 0 0 1 1 _B Not supported. The speed defaults to 2.5 Gbps. 0 1 0 0 _B Not supported. The speed defaults to 2.5 Gbps. 0 1 0 1 _B Not supported. The speed defaults to 2.5 Gbps. 0 1 1 0 _B 2.5 Gbps 0 1 1 1 _B Not supported 1 x x x _B Reserved

Field	Bits	Type	Description (cont'd)
NS1	1	RO	Not Supported PMA remote loopback mode is not supported by the GPHY.
NS2	0	RO	Not Supported PMA local loopback mode is not supported by the GPHY.

PHY Identifier 1 (Register 1.2)

IEEE Standard Register=1.2

Bits 31 - 16 of device ID

PMA_DEVID1

Reset Value

PHY Identifier 1 (Register 1.2)

C133_H

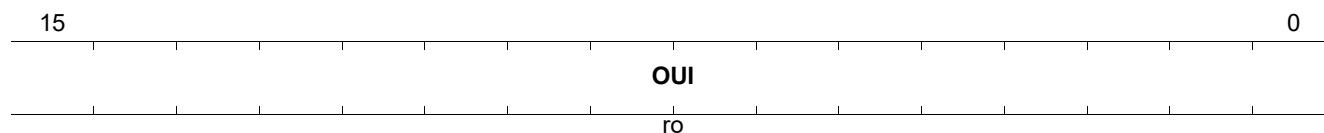

Field	Bits	Type	Description
OUI	15:0	RO	Organizationally Unique Identifier Organizationally Unique Identifier Bits 3:18

PHY Identifier 2 (Register 1.3)

IEEE Standard Register=1.3

Bits 15 - 0 of device ID

PMA_DEVID2

PHY Identifier 2 (Register 1.3)

Reset Value

5400_H



Field	Bits	Type	Description
OUI	15:10	RO	Organizationally Unique Identifier Bits 19:24
LDN	9:4	RO	Device Number Specifies the device number ¹⁾ to distinguish between several different products.
LDRN	3:0	RO	Device Revision Number Specifies the device revision number ¹⁾ to distinguish between several versions of this device.

1) For the device specific reset value, see the Product and Package Naming table in the [Product Ordering Information](#) chapter.

PMA/PMD Speed Ability (Register 1.4)

IEEE Standard Register=1.4

PMA_SPEED_ABILITY
Reset Value
PMA/PMD Speed Ability (Register 1.4)
2070_H

15	14	13	12	11	10	9	8	7	6	5	4	3	2	1	0
RES	CAP_5G	CAP_2G5	RES2	RES	RES	CAP_100G	CAP_40G	CAP_10_1G*	CAP_10M	CAP_100M	CAP_1000M	RES	R10PASS*	CAP_2BA*	CAP_10G*
	ro	ro	ro			ro	ro	ro	ro	ro	ro		ro	ro	ro

Field	Bits	Type	Description
CAP_5G	14	RO	Not Supported 0 _B PMA/PMD is not capable of operating as 5 Gbps. 1 _B PMA/PMD is capable of operating at 5 Gbps.
CAP_2G5	13	RO	2.5 G capable 0 _B PMA/PMD is not capable of operating as 2.5 Gbps. 1 _B PMA/PMD is capable of operating at 2.5 Gbps.
RES2	12	RO	Reserved Value always 0
CAP_100G	9	RO	Not Supported 0 _B PMA/PMD is not capable of operating as 100 Gbps. 1 _B PMA/PMD is capable of operating at 100 Gbps.
CAP_40G	8	RO	Not Supported 0 _B PMA/PMD is not capable of operating as 40 Gbps. 1 _B PMA/PMD is capable of operating at 40 Gbps.
CAP_10_1G	7	RO	Not Supported 0 _B PMA/PMD is not capable of operating at 10 Gbps downstream and 1 Gbps upstream. 1 _B PMA/PMD is capable of operating at 10 Gbps downstream and 1 Gbps upstream.
CAP_10M	6	RO	10M capable 0 _B PMA/PMD is not capable of operating as 10 Mbps. 1 _B PMA/PMD is capable of operating at 10 Mbps.
CAP_100M	5	RO	100M capable 0 _B PMA/PMD is not capable of operating as 100 Mbps. 1 _B PMA/PMD is capable of operating at 100 Mbps.
CAP_1000M	4	RO	1000M capable 0 _B PMA/PMD is not capable of operating as 1000 Mbps. 1 _B PMA/PMD is capable of operating at 1000 Mbps.
R10PASS_TS_CAPABLE	2	RO	Not Supported 0 _B PMA/PMD is not capable of operating as 10PASS-TS. 1 _B PMA/PMD is capable of operating as 10PASS-TS.

Field	Bits	Type	Description (cont'd)
CAP_2BASE_TL	1	RO	Not Supported 0 _B PMA/PMD is not capable of operating as 2BASE-TL. 1 _B PMA/PMD is capable of operating as 2BASE-TL.
CAP_10G_CAPP	0	RO	Not Supported 0 _B PMA/PMD is not capable of operating at 10 Gbps. 1 _B PMA/PMD is capable of operating at 10 Gbps.

Devices in Package 1 (Register 1.5)

IEEE Standard Register=1.5

PMA_DIP1
Devices in Package 1 (Register 1.5)
Reset Value
008B_H

15	12	11	10	9	8	7	6	5	4	3	2	1	0
RES		SEP_P MA*	SEP_P MA*	SEP_P MA*	SEP_P MA*	ANEG	TC	DTE_X S	PHY_X S	PCS	WIS	PMD_ PMA	CLAU SE_*
ro		ro	ro	ro	ro	ro	ro	ro	ro	ro	ro	ro	ro

Field	Bits	Type	Description
RES	15:12	RO	Reserved Ignore on read
SEP_PMA_4	11	RO	Separate PMA (4) 0 _B Separate PMA (4) not present in package 1 _B Separate PMA (4) present in package
SEP_PMA_3	10	RO	Separate PMA (3) 0 _B Separate PMA (3) not present in package 1 _B Separate PMA (3) present in package
SEP_PMA_2	9	RO	Separate PMA (2) 0 _B Separate PMA (2) not present in package 1 _B Separate PMA (2) present in package
SEP_PMA_1	8	RO	Separate PMA (1) 0 _B Separate PMA (1) not present in package 1 _B Separate PMA (1) present in package
ANEG	7	RO	Auto-Negotiation Present This bit is always set to 1 _B in the GPHY. 0 _B ANEG not present in package 1 _B ANEG present in package
TC	6	RO	TC Present 0 _B TC not present in package 1 _B TC present in package
DTE_XS	5	RO	DTE XS Present 0 _B DTE XS not present in package 1 _B DTE XS present in package
PHY_XS	4	RO	PHY XS Present 0 _B PHY XS not present in package 1 _B PHY XS present in package
PCS	3	RO	PCS Present This bit is always set to 1 _B in the GPHY. 0 _B PCS not present in package 1 _B PCS present in package

Field	Bits	Type	Description (cont'd)
WIS	2	RO	WIS Present 0 _B WIS not present in package 1 _B WIS present in package
PMD_PMA	1	RO	PMD/PMA Present This bit is always set to 1 _B in the GPHY. 0 _B PMA/PMD not present in package 1 _B PMA/PMD present in package
CLAUSE_22	0	RO	Clause 22 Registers Present This bit is always set to 1 _B in the GPHY. 0 _B Clause 22 registers not present in package 1 _B Clause 22 registers present in package

Devices in Package 2 (Register 1.6)

IEEE Standard Register=1.6

PMA_DIP2

Reset Value

Devices in Package 2 (Register 1.6)

C000_H

15	14	13	12								0
VSPE C2	VSPE C1	CLA_2 2_*	RES								
ro	ro	ro	ro								

Field	Bits	Type	Description
VSPEC2	15	RO	Vendor-specific Device 2 This bit is always set to 1 _B in the GPHY. 0 _B Vendor-specific device 2 not present in package 1 _B Vendor-specific device 2 present in package
VSPEC1	14	RO	Vendor-specific Device 1 This bit is always set to 1 _B in the GPHY. 0 _B Vendor-specific device 1 not present in package 1 _B Vendor-specific device 1 present in package
CLA_22_EXT	13	RO	Clause 22 Extension 0 _B Clause 22 extension not present in package 1 _B Clause 22 extension present in package
RES	12:0	RO	Reserved Ignore on read.

PMA/PMD Control 2 (Register 1.7)

IEEE Standard Register=1.7

PMA_CTL2

PMA/PMD Control 2 (Register 1.7)

Reset Value

0030_H

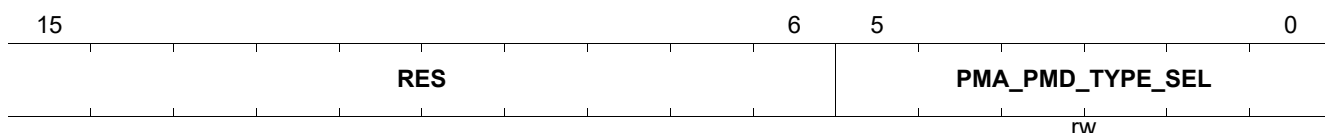

Field	Bits	Type	Description
PMA_PMD_TY PE_SEL	5:0	RW	PMA/PMD Type Selection 5 4 3 2 1 0 Others = Reserved 1 1 0 0 0 1 _B Unsupported, defaults to 2.5GBASE-T PMA 1 1 0 0 0 0 _B 2.5GBASE-T PMA 1 0 1 1 x _B Unsupported, defaults to 2.5GBASE-T PMA 1 0 1 0 1 1 _B Unsupported, defaults to 2.5GBASE-T PMA 1 0 1 0 1 0 _B Unsupported, defaults to 2.5GBASE-T PMA 1 0 1 0 0 1 _B Unsupported, defaults to 2.5GBASE-T PMA 1 0 1 0 0 0 _B Unsupported, defaults to 2.5GBASE-T PMA 1 0 0 1 1 x _B Unsupported, defaults to 2.5GBASE-T PMA 1 0 0 1 0 1 _B Unsupported, defaults to 2.5GBASE-T PMA 1 0 0 1 0 0 _B Unsupported, defaults to 2.5GBASE-T PMA 1 0 0 0 1 1 _B Unsupported, defaults to 2.5GBASE-T PMA 1 0 0 0 1 0 _B Unsupported, defaults to 2.5GBASE-T PMA 1 0 0 0 0 1 _B Unsupported, defaults to 2.5GBASE-T PMA 1 0 0 0 0 0 _B Unsupported, defaults to 2.5GBASE-T PMA 0 1 1 1 x _B Unsupported, defaults to 2.5GBASE-T PMA 0 1 1 0 1 1 _B Unsupported, defaults to 2.5GBASE-T PMA 0 1 1 0 1 0 _B Unsupported, defaults to 2.5GBASE-T PMA 0 1 1 0 0 1 _B Unsupported, defaults to 2.5GBASE-T PMA 0 1 1 0 0 0 _B Unsupported, defaults to 2.5GBASE-T PMA 0 1 0 1 1 1 _B Unsupported, defaults to 2.5GBASE-T PMA 0 1 0 1 1 0 _B Unsupported, defaults to 2.5GBASE-T PMA 0 1 0 1 0 1 _B Unsupported, defaults to 2.5GBASE-T PMA 0 1 0 1 0 0 _B Unsupported, defaults to 2.5GBASE-T PMA 0 1 0 0 1 1 _B Unsupported, defaults to 2.5GBASE-T PMA 0 1 0 0 1 0 _B Unsupported, defaults to 2.5GBASE-T PMA 0 1 0 0 0 1 _B Unsupported, defaults to 2.5GBASE-T PMA 0 1 0 0 0 0 _B Unsupported, defaults to 2.5GBASE-T PMA

Field	Bits	Type	Description (cont'd)
PMA_PMD_TY PE_SEL	5:0	RW	PMA/PMD Type Selection (cont'd) 0 0 1 1 1 1 _B 10BASE-T PMA/PMD 0 0 1 1 1 0 _B 100BASE-TX PMA/PMD 0 0 1 1 0 1 _B Unsupported, defaults to 2.5GBASE-T PMA 0 0 1 1 0 0 _B 1000BASE-T PMA/PMD 0 0 1 0 1 1 _B Unsupported, defaults to 2.5GBASE-T PMA 0 0 1 0 1 0 _B Unsupported, defaults to 2.5GBASE-T PMA 0 0 1 0 0 1 _B Unsupported, defaults to 2.5GBASE-T PMA 0 0 1 0 0 0 _B Unsupported, defaults to 2.5GBASE-T PMA 0 0 0 1 1 1 _B Unsupported, defaults to 2.5GBASE-T PMA 0 0 0 1 1 0 _B Unsupported, defaults to 2.5GBASE-T PMA 0 0 0 1 0 1 _B Unsupported, defaults to 2.5GBASE-T PMA 0 0 0 1 0 0 _B Unsupported, defaults to 2.5GBASE-T PMA 0 0 0 0 1 1 _B Unsupported, defaults to 2.5GBASE-T PMA 0 0 0 0 1 0 _B Unsupported, defaults to 2.5GBASE-T PMA 0 0 0 0 0 1 _B Unsupported, defaults to 2.5GBASE-T PMA 0 0 0 0 0 0 _B Unsupported, defaults to 2.5GBASE-T PMA

PMA/PMD Status 2 (Register 1.8)

IEEE Standard Register=1.8

PMA_STAT2

PMA/PMD Status 2 (Register 1.8)

Reset Value

8200_H

15	14	13	12	11	10	9	8	7	6	5	4	3	2	1	0
DEVICE_PRE SENT	TX_FAULT*	RX_FAULT*	TX_FAULT	RX_FAULT	EXT_ABILITY*	PMD_TX_DISABLE*	RMGB_T_S*	RMGB_T_L*	RMGB_T_E*	RMGB_T_L*	RMGB_T_S*	RMGB_T_L*	RMGB_T_E*	PMA_LOC*	
ro	ro	ro	ro	ro	ro	ro	ro	ro	ro	ro	ro	ro	ro	ro	ro

Field	Bits	Type	Description
DEVICE_PRE SENT	15:14	RO	Device Present 00 _B No device responding at this address 01 _B No device responding at this address 10 _B Device responding at this address 11 _B No device responding at this address
TX_FAULT_ABILITY	13	RO	Transmit Fault Ability 0 _B PMA/PMD is not able to detect a fault condition on the transmit path. 1 _B PMA/PMD is able to detect a fault condition on the transmit path.
RX_FAULT_ABILITY	12	RO	Receive Fault Ability 0 _B PMA/PMD is not able to detect a fault condition on the receive path. 1 _B PMA/PMD is able to detect a fault condition on the receive path.
TX_FAULT	11	RO	Transmit Fault 0 _B No fault condition on transmit path 1 _B Fault condition on transmit path
RX_FAULT	10	RO	Receive Fault 0 _B No fault condition on receive path 1 _B Fault condition on receive path
EXT_ABILITIES	9	RO	Extended Abilities 0 _B PMA/PMD does not have extended abilities. 1 _B PMA/PMD has extended abilities listed in register 1.11.
PMD_TX_DISABLE	8	RO	PMD Transmit Disable 0 _B PMD is not able to disable the transmit path. 1 _B PMD is able to disable the transmit path.
RMGBT_SR_ABILITY	7	RO	MULTIGBASE-SR Ability 0 _B PMA/PMD is not able to perform MULTIGBASE-SR. 1 _B PMA/PMD is able to perform MULTIGBASE-SR.
RMGBT_LR_ABILITY	6	RO	MULTIGBASE-LR Ability 0 _B PMA/PMD is not able to perform MULTIGBASE-LR. 1 _B PMA/PMD is able to perform MULTIGBASE-LR.
RMGBT_ER_ABILITY	5	RO	MULTIGBASE-ER Ability 0 _B PMA/PMD is not able to perform MULTIGBASE-ER. 1 _B PMA/PMD is able to perform MULTIGBASE-ER.

Field	Bits	Type	Description (cont'd)
RMGBT_LX4_ABILITY	4	RO	MULTIGBASE-LX4 Ability 0 _B PMA/PMD is not able to perform MULTIGBASE-LX4. 1 _B PMA/PMD is able to perform MULTIGBASE-LX4.
RMGBT_SW_ABILITY	3	RO	MULTIGBASE-SW Ability 0 _B PMA/PMD is not able to perform MULTIGBASE-SW. 1 _B PMA/PMD is able to perform MULTIGBASE-SW.
RMGBT_LW_ABILITY	2	RO	MULTIGBASE-LW Ability 0 _B PMA/PMD is not able to perform MULTIGBASE-LW. 1 _B PMA/PMD is able to perform MULTIGBASE-LW.
RMGBT_EW_ABILITY	1	RO	MULTIGBASE-EW Ability 0 _B PMA/PMD is not able to perform MULTIGBASE-EW. 1 _B PMA/PMD is able to perform MULTIGBASE-EW.
PMA_LOCAL_LOOPBACK	0	RO	PMA Local Loopback 0 _B PMA is not able to perform a local loopback function. 1 _B PMA is able to perform a local loopback function.

PMA/PMD Extended Ability (Register 1.11)

IEEE Standard Register=1.11

PMA_EXT_ABILITY

PMA/PMD Extended Ability (Register 1.11)

Reset Value

41A0_H

15	14	13		11	10	9	8	7	6	5	4	3	2	1	0
RES	R2G5_EX*		RES		R40G_10*	P2MP_AB*	R10B_ASE*	R100B_AS*	R1000_BA*	R1000_BA*	RMGB_T_K*	RMGB_T_K*	RMGB_T_A*	RMGB_T_L*	RMGB_T_C*
	ro				ro	ro	ro	ro	ro	ro	ro	ro	ro	ro	ro

Field	Bits	Type	Description
R2G5_EXT_ABILITIES	14	RO	2.5G/5G Extended Abilities 0 _B PMA/PMD does not have 2.5G/5G extended abilities. 1 _B PMA/PMD has 2.5G/5G extended abilities listed in register 1.21.
R40G_100G_EXT_ABILITIES	10	RO	40G/100G Extended Abilities 0 _B PMA/PMD does not have 40G/100G extended abilities. 1 _B PMA/PMD has 40G/100G extended abilities listed in register 1.13.
P2MP_ABILITY	9	RO	P2MP Ability 0 _B PMA/PMD does not have P2MP extended abilities. 1 _B PMA/PMD has P2MP abilities listed in register 1.12.
R10BASE_T_ABILITY	8	RO	10BASE-T Ability 0 _B PMA/PMD is not able to perform 10BASE-T. 1 _B PMA/PMD is able to perform 10BASE-T.
R100BASE_TX_ABILITY	7	RO	100BASE-TX Ability 0 _B PMA/PMD is not able to perform 100BASE-TX. 1 _B PMA/PMD is able to perform 100BASE-TX.
R1000BASE_KX_ABILITY	6	RO	1000BASE-KX Ability 0 _B PMA/PMD is not able to perform 1000BASE-KX. 1 _B PMA/PMD is able to perform 1000BASE-KX.
R1000BASE_T_ABILITY	5	RO	1000BASE-T Ability 0 _B PMA/PMD is not able to perform 1000BASE-T. 1 _B PMA/PMD is able to perform 1000BASE-T.
RMGBT_KR_ABILITY	4	RO	MULTIGBASE-KR Ability 0 _B PMA/PMD is not able to perform MULTIGBASE-KR. 1 _B PMA/PMD is able to perform MULTIGBASE-KR.
RMGBT_KX4_ABILITY	3	RO	MULTIGBASE-KX4 Ability 0 _B PMA/PMD is not able to perform MULTIGBASE-KX4. 1 _B PMA/PMD is able to perform MULTIGBASE-KX4.
RMGBT_ABILITY	2	RO	10GBASE-T Ability 0 _B PMA/PMD is not able to perform MULTIGBASE-T. 1 _B PMA/PMD is able to perform MULTIGBASE-T.
RMGBT_LRM_ABILITY	1	RO	MULTIGBASE-LRM Ability 0 _B PMA/PMD is not able to perform MULTIGBASE-LRM. 1 _B PMA/PMD is able to perform MULTIGBASE-LRM.

Field	Bits	Type	Description (cont'd)
RMGBT_CX4_ABILITY	0	RO	MULTIGBASE-CX4 Ability 0 _B PMA/PMD is not able to perform MULTIGBASE-CX4. 1 _B PMA/PMD is able to perform MULTIGBASE-CX4.

AN Package Identifier (Register 1.14)

IEEE Standard Register=1.14

PMA_PACKID1

Reset Value

AN Package Identifier (Register 1.14)

C133_H

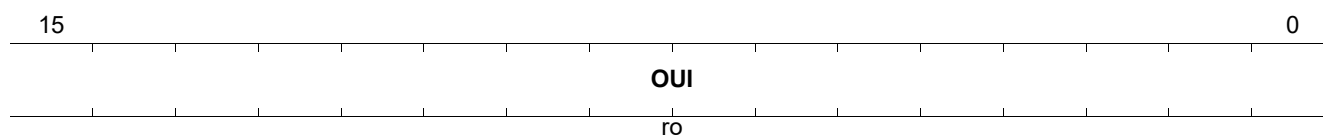

Field	Bits	Type	Description
OUI	15:0	RO	Organizationally Unique Identifier Organizationally Unique Identifier Bits 3:18

AN Package Identifier (Register 1.15)

IEEE Standard Register=1.15

PMA_PACKID2

AN Package Identifier (Register 1.15)

Reset Value

5400_H

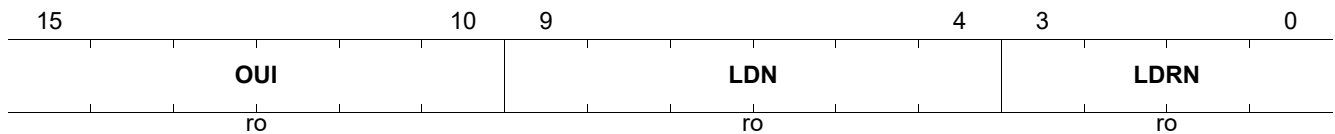

Field	Bits	Type	Description
OUI	15:10	RO	Organizationally Unique Identifier Bits 19:24
LDN	9:4	RO	Device Number Specifies the device number ¹⁾ to distinguish between several different products.
LDRN	3:0	RO	Device Revision Number Specifies the device revision number ¹⁾ to distinguish between several versions of this device.

1) For the device specific reset value, see the Product and Package Naming table in the [Product Ordering Information](#) chapter.

PMA_MGMT_EXTENDED_ABILITY (Register 1.21)

Read only. Write from the STA has no effect.

IEEE Standard Register=1.21

PMA_MGMT_EXTENDED_ABILITY

PMA_MGMT_EXTENDED_ABILITY (Register 1.21)

Reset Value

0001_H

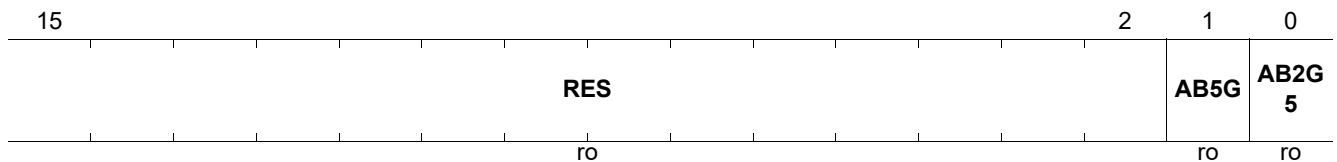

Field	Bits	Type	Description
RES	15:2	RO	Reserved Value always 0
AB5G	1	RO	PMA Ability to Perform 5GBASE-T 0 _B UNABLE PMA is not able to perform 5GBASE-T. 1 _B ABLE PMA is able to perform 5GBASE-T.
AB2G5	0	RO	PMA Ability to Perform 2.5GBASE-T 0 _B UNABLE PMA is not able to perform 2.5GBASE-T. 1 _B ABLE PMA is able to perform 2.5GBASE-T.

MULTIGBASE-T Status (Register 1.129)

IEEE Standard Register=1.129

Indicates startup for 2.5G was completed.

When read as a 1, indicates that the startup protocol (for 2.5G/5GBASE-T) was completed (link_status = OK, pcs_status = OK), and that the contents of bits 1.130.11:0 (Polarity), 1.131.15:10 (PBO), 1.145.14:8 (Skew), 1.146.14:8, and 1.146.6:0 (Skew), established during the startup protocol, are valid.

When read as a 0, indicates that the startup process was not completed, and that the contents of bit 1.129.0, established during the startup protocol, are invalid. A PMA must return a value of 0 in bit 1.129.1 when the PMA link_status = FAIL.

PMA_MGBT_STAT		Reset Value
MULTIGBASE-T Status (Register 1.129)		0000_H
15	1	0
RES		LP_IN FO*
		RO

Field	Bits	Type	Description
LP_INFORMATION_VALID	0	RO	<p>LP Information Valid</p> <p>When set, this bit indicates the startup protocol (126.4.2.5) was completed.</p> <p>0_B Link partner information is invalid</p> <p>1_B Link partner information is valid</p>

MULTIGBASE-T Pair Swap and Polarity (Register 1.130)

IEEE Standard Register=1.130

PMA_MGBT_POLARITY

Reset Value

MULTIGBASE-T Pair Swap and Polarity (Register 1.130)

0003_H

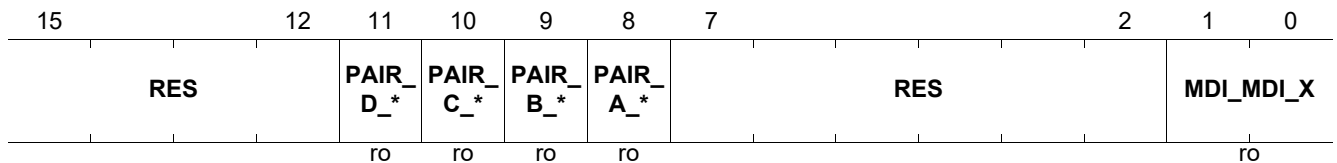

Field	Bits	Type	Description
PAIR_D_POLARITY	11	RO	Pair D Polarity 0 _B Polarity of pair D is not reversed. 1 _B Polarity of pair D is reversed.
PAIR_C_POLARITY	10	RO	Pair C Polarity 0 _B Polarity of pair C is not reversed. 1 _B Polarity of pair C is reversed.
PAIR_B_POLARITY	9	RO	Pair B Polarity 0 _B Polarity of pair B is not reversed. 1 _B Polarity of pair B is reversed.
PAIR_A_POLARITY	8	RO	Pair A Polarity 0 _B Polarity of pair A is not reversed. 1 _B Polarity of pair A is reversed.
MDI_MDI_X	1:0	RO	MDI/MDI-X Indicates the status of pair swaps at the MDI / MD-X. 00 _B ABCD CROSS Pair AB and Pair CD crossover 01 _B CD CROSS Pair CD crossover only 10 _B AB CROSS Pair AB crossover only 11 _B NORMAL No crossover

MULTIGBASE-T Tx Power Backoff and PHY Short Reach Setting (Register 1.131)

IEEE Standard Register=1.131

PMA_MGBT_TX_PBO

Reset Value

MULTIGBASE-T TX Power Backoff and PHY Short Reach Setting (Register 1.131)

0000_H

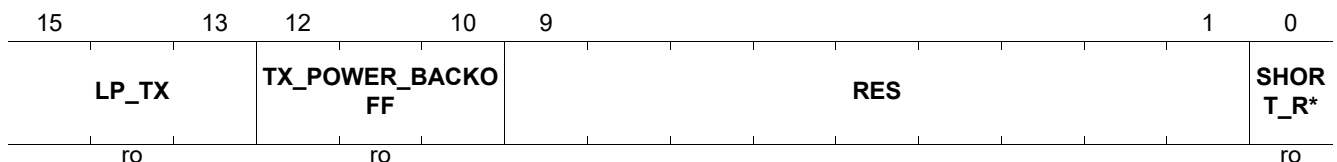

Field	Bits	Type	Description
LP_TX	15:13	RO	Link Partner Tx The power backoff setting of the link partner. The bit number assignment order is: 15 14 13 000 _B 0 dB 001 _B 2 dB 010 _B 4 dB 011 _B 6 dB 100 _B 8 dB 101 _B 10 dB 110 _B 12 dB 111 _B 14 dB
TX_POWER_BACKOFF	12:10	RO	Tx Power Backoff The power backoff of PHY211 PMA. The bit number assignment order is: 12 11 10 000 _B 0 dB 001 _B 2 dB 010 _B 4 dB 011 _B 6 dB 100 _B 8 dB 101 _B 10 dB 110 _B 12 dB 111 _B 14 dB
SHORT_REACH_MODE	0	RO	Short Reach Mode 0 _B PHY is not operating in short reach mode 1 _B PHY is operating in short reach mode (not supported)

MULTIGBASE-T Test Mode (Register 1.132)

IEEE Standard Register=1.132

PMA_MGBT_TEST_MODE

MULTIGBASE-T Test Mode (Register 1.132)

Reset Value

0000_H

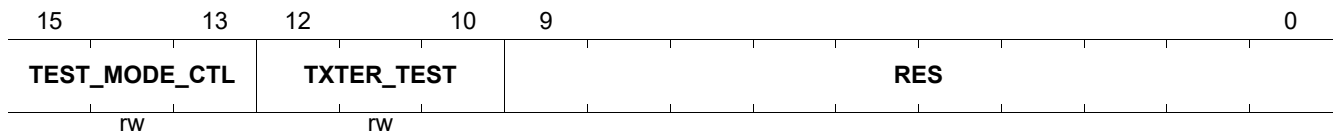

Field	Bits	Type	Description
TEST_MODE_CTL	15:13	RW	Test Mode Control 000 _B Normal operation 001 _B Test mode 1 010 _B Test mode 2 011 _B Test mode 3 100 _B Test mode 4 101 _B Test mode 5 110 _B Test mode 6 111 _B Test mode 7
TXTER_TEST	12:10	RW	Transmitter Test Frequencies for tones used in Test Mode 4. 000 _B Reserved 001 _B Dual tone 1 010 _B Dual tone 2 011 _B Reserved 100 _B Dual tone 3 101 _B Dual tone 4 110 _B Dual tone 5 111 _B Reserved

MULTIGBASE-T SNR Margin Channel A (Register 1.133)

Register 1.133 contains the current SNR operating margin measured at the slicer input for channel A for the MULTIGBASE-T PMA.

IEEE Standard Register=1.133

PMA_MGBT_SNR_OPMARGIN_A

Reset Value

MULTIGBASE-T SNR Margin Channel A (Register 1.133)

0000_H

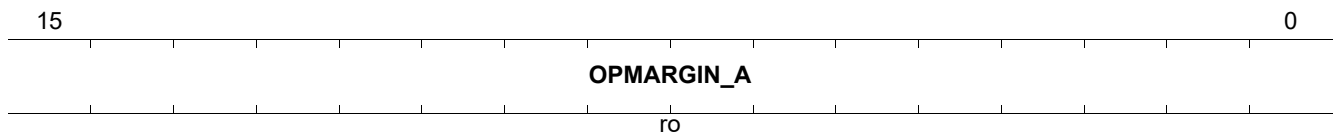

Field	Bits	Type	Description
OPMARGIN_A	15:0	RO	OPMARGIN_A SNR operating margin measured at the slicer input for channel A

MULTIGBASE-T SNR Margin Channel B (Register 1.134)

Register 1.134 contains the current SNR operating margin measured at the slicer input for channel B for the MULTIGBASE-T PMA.

IEEE Standard Register=1.134

PMA_MGBT_SNR_OPMARGIN_B

Reset Value

MULTIGBASE-T SNR Margin Channel B (Register 1.134)

0000_H

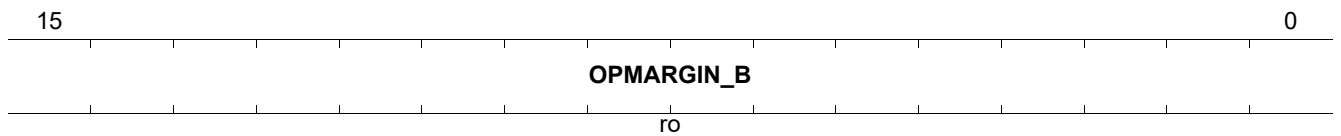

Field	Bits	Type	Description
OPMARGIN_B	15:0	RO	OPMARGIN_B SNR operating margin measured at the slicer input for channel B

MULTIGBASE-T SNR Margin Channel C (Register 1.135)

Register 1.135 contains the current SNR operating margin measured at the slicer input for channel C for the MULTIGBASE-T PMA.

IEEE Standard Register=1.135

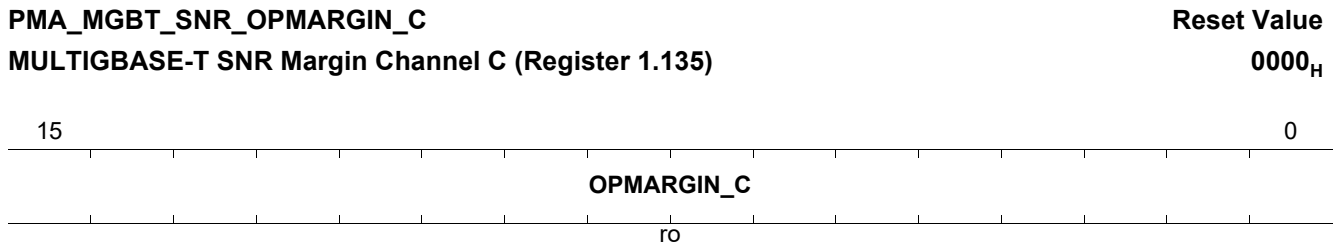

Field	Bits	Type	Description
OPMARGIN_C	15:0	RO	OPMARGIN_C SNR operating margin measured at the slicer input for channel C

MULTIGBASE-T SNR Margin Channel D (Register 1.136)

Register 1.136 contains the current SNR operating margin measured at the slicer input for channel D for the MULTIGBASE-T PMA.

IEEE Standard Register=1.136

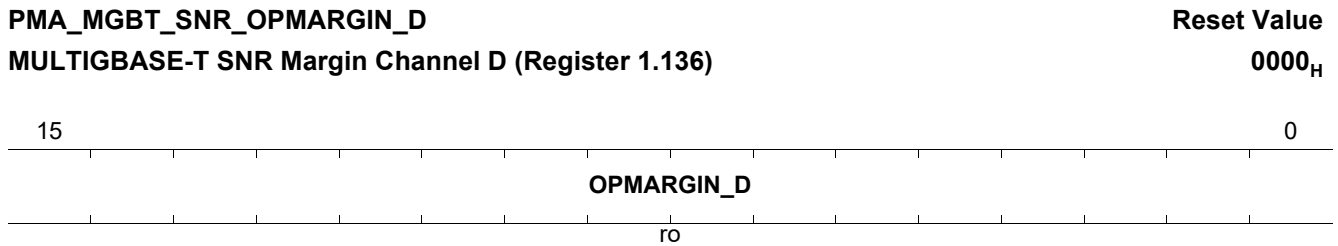

Field	Bits	Type	Description
OPMARGIN_D	15:0	RO	OPMARGIN_D SNR operating margin measured at the slicer input for channel D

MULTIGBASE-T SNR Minimum Margin Channel A (Register 1.137)

The minimum margin channel A register contains a latched copy of the lowest value observed in the SNR operating margin channel A register (1.133) since the last read.

IEEE Standard Register=1.137

PMA_MGBT_MINMARGIN_A

Reset Value

MULTIGBASE-T SNR Minimum Margin Channel A (Register 1.137)

0000_H

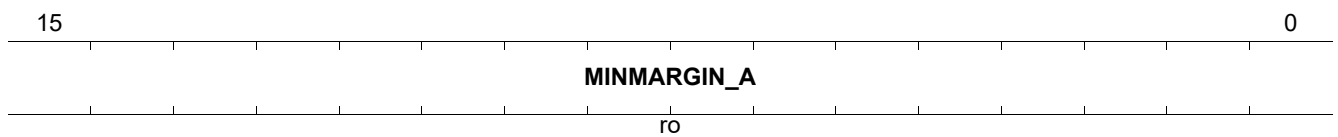

Field	Bits	Type	Description
MINMARGIN_A	15:0	RO	MINMARGIN_A Lowest value observed in the SNR operating margin channel A register (1.133) since the last read

MULTIGBASE-T SNR Minimum Margin Channel B (Register 1.138)

The minimum margin channel A register contains a latched copy of the lowest value observed in the SNR operating margin channel B register (1.134) since the last read.

IEEE Standard Register=1.138

PMA_MGBT_MINMARGIN_B

Reset Value

MULTIGBASE-T SNR Minimum Margin Channel B (Register 1.138)

0000_H

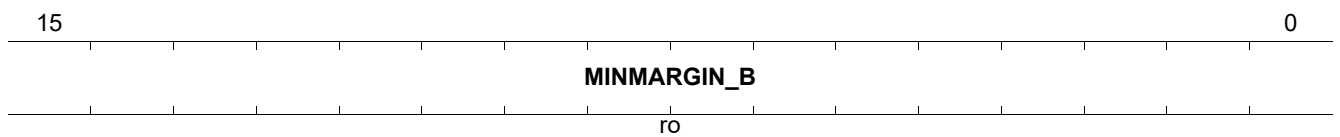

Field	Bits	Type	Description
MINMARGIN_B	15:0	RO	MINMARGIN_B Lowest value observed in the SNR operating margin channel B register (1.134) since the last read

MULTIGBASE-T SNR Minimum Margin Chan C (Register 1.139)

The minimum margin channel C register contains a latched copy of the lowest value observed in the SNR operating margin channel C register (1.135) since the last read.

IEEE Standard Register=1.139

PMA_MGBT_MINMARGIN_C

Reset Value

MULTIGBASE-T SNR Minimum Margin Chan C (Register 1.139)

0000_H

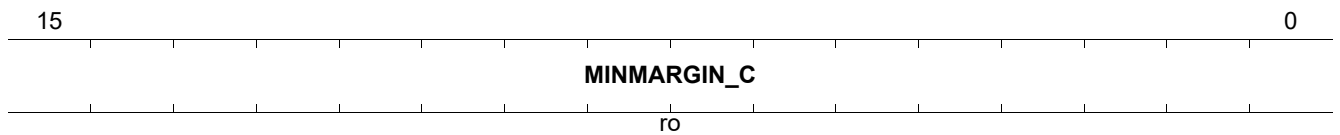

Field	Bits	Type	Description
MINMARGIN_C	15:0	RO	MINMARGIN_C Lowest value observed in the SNR operating margin channel C register (1.135) since the last read

MULTIGBASE-T SNR Minimum Margin Chan D (Register 1.140)

The Minimum margin channel D register contains a latched copy of the lowest value observed in the SNR operating margin channel D register (1.136) since the last read.

IEEE Standard Register=1.140

PMA_MGBT_MINMARGIN_D

Reset Value

MULTIGBASE-T SNR Minimum Margin Chan D (Register 1.140)

0000_H

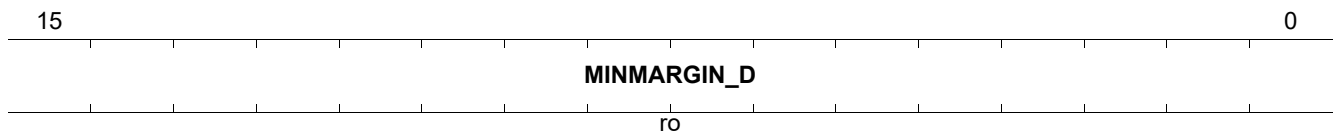

Field	Bits	Type	Description
MINMARGIN_D	15:0	RO	MINMARGIN_D Lowest value observed in the SNR operating margin channel D register (1.136) since the last read

MULTIGBASE-T Rx Power Channel A (Register 1.141)

The Rx signal power channel A register is read only and contains the receive signal power measured at the MDI during training as described in 55.4.3.1.

IEEE Standard Register=1.141

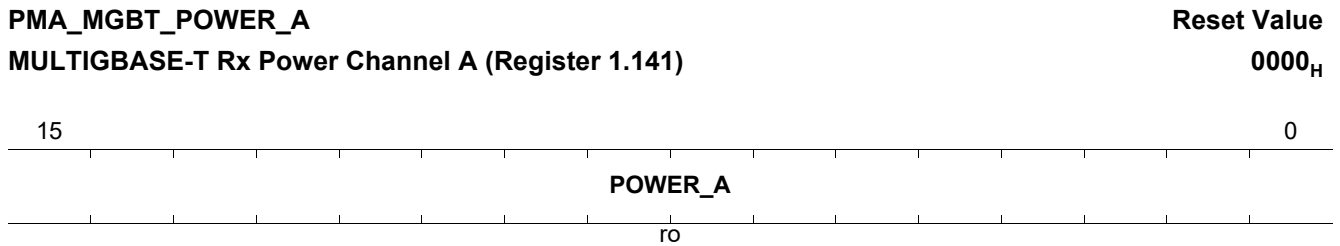

Field	Bits	Type	Description
POWER_A	15:0	RO	POWER_A Receive signal power measured at the MDI during training

MULTIGBASE-T Rx Power Channel B (Register 1.142)

The Rx signal power channel B register is read only and contains the receive signal power measured at the MDI during training as described in 55.4.3.1.

IEEE Standard Register=1.142

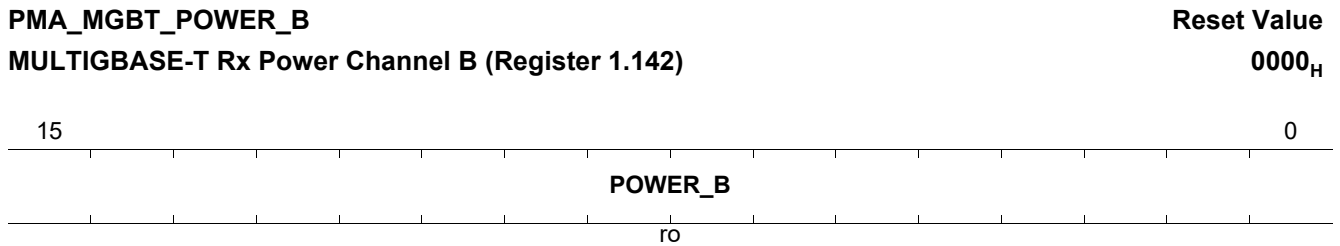

Field	Bits	Type	Description
POWER_B	15:0	RO	POWER_B Receive signal power measured at the MDI during training

MULTIGBASE-T Rx Power Chan C (Register 1.143)

The Rx signal power channel C register is read only and contains the receive signal power measured at the MDI during training as described in 55.4.3.1.

IEEE Standard Register=1.143

PMA_MGBT_POWER_C

Reset Value

MULTIGBASE-T Rx Power Chan C (Register 1.143)

0000_H

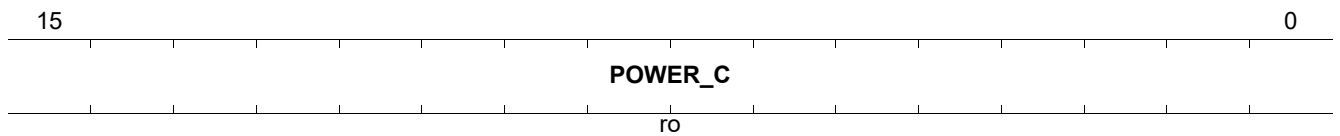

Field	Bits	Type	Description
POWER_C	15:0	RO	POWER_C Receive signal power measured at the MDI during training

MULTIGBASE-T Rx Power Chan D (Register 1.144)

The Rx signal power channel D register is read only and contains the receive signal power measured at the MDI during training as described in 55.4.3.1.

IEEE Standard Register=1.144

PMA_MGBT_POWER_D

Reset Value

MULTIGBASE-T Rx Power Chan D (Register 1.144)

0000_H

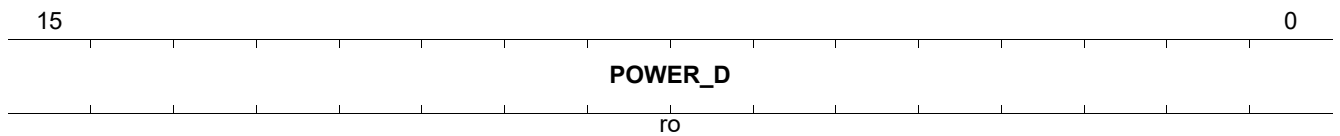

Field	Bits	Type	Description
POWER_D	15:0	RO	POWER_D Receive signal power measured at the MDI during training

MULTIGBASE-T Skew Delay 0 (Register 1.145)

IEEE Standard Register=1.145

The skew delay reports the current skew delay on each of the pairs with respect to physical pair A. It is reported with 1.25 ns resolution to an accuracy of 2.5 ns. The number is in two's complement notation with positive values representing delay and negative values representing advance with respect to physical pair A. When the delay exceeds the maximum amount represented by the range -80 ns to +78.75 ns, the field displays the maximum value.

PMA_MGBT_SKEW_DELAY_0

Reset Value

MULTIGBASE-T Skew Delay 0 (Register 1.145)

0000_H

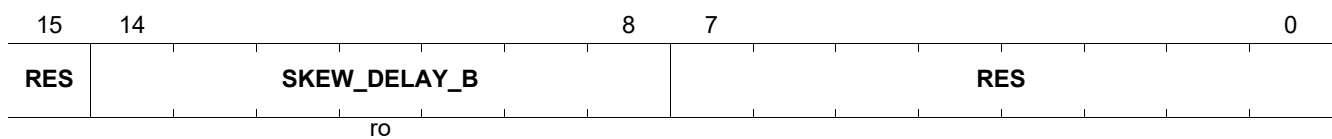

Field	Bits	Type	Description
SKEW_DELAY_B	14:8	RO	Skew Delay B Skew delay for pair B

MULTIGBASE-T Skew Delay 1 (Register 1.146)

IEEE Standard Register=1.146

The skew delay reports the current skew delay on each of the pairs with respect to physical pair A. It is reported with 1.25 ns resolution to an accuracy of 2.5 ns. The number is in two's complement notation with positive values representing delay and negative values representing advance with respect to physical pair A. When the delay exceeds the maximum amount represented by the range -80 ns to +78.75 ns, the field displays the maximum value.

PMA_MGBT_SKEW_DELAY_1

Reset Value

MULTIGBASE-T Skew Delay 1 (Register 1.146)

0000_H

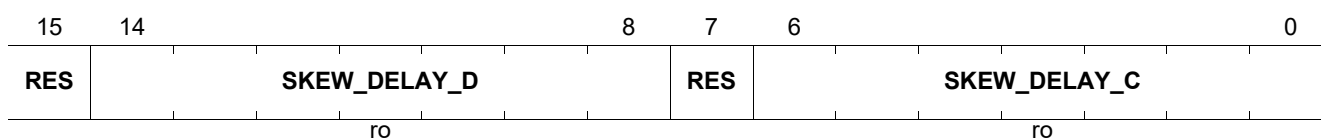

Field	Bits	Type	Description
SKEW_DELAY_D	14:8	RO	Skew Delay D Skew delay for pair D
SKEW_DELAY_C	6:0	RO	Skew Delay C Skew delay for pair C

MULTIGBASE-T Skew Delay 2 (Register 1.147)

IEEE Standard Register=1.147

PMA_MGBT_FAST_RETRAIN_STA_CTRL
MULTIGBASE-T Skew Delay 2 (Register 1.147)

Reset Value

0010_H

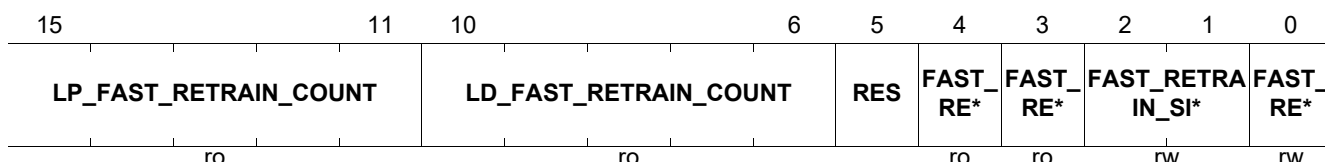

Field	Bits	Type	Description
LP_FAST_RETRAIN_COUNT	15:11	RO	LP Fast Retrain Count Counts the number of fast retrains requested by the link partner.
LD_FAST_RETRAIN_COUNT	10:6	RO	LD Fast Retrain Count Counts the number of fast retrains requested by the local device.
FAST_RETRAIN_ABILITY	4	RO	Fast Retrain Ability 0 _B Fast retrain capability is not supported. 1 _B Fast retrain capability is supported.
FAST_RETRAIN_NEGOTIATED	3	RO	Fast Retrain Negotiated 0 _B Fast retrain capability was not negotiated. 1 _B Fast retrain capability was negotiated.
FAST_RETRAIN_SIG_TYPE	2:1	RW	Fast Retrain Signal Type 00 _B PHY signals IDLE during fast retrain 01 _B PHY signals local fault during fast retrain 10 _B PHY signals link interruption during fast retrain 11 _B Reserved
FAST_RETRAIN_ENABLE	0	RW	Fast Retrain Enable 0 _B Fast retrain capability is disabled. 1 _B Fast retrain capability is enabled.

PMA TimeSync Capability Indication (Register 1.1800)

PMA TimeSync Capability indication register.

GPHY does not support providing data path delay information.

IEEE Standard Register=1.1800

PMA_TIMESYNC_CAP

Reset Value

PMA TimeSync Capability Indication (Register 1.1800)

0000_H



Field	Bits	Type	Description
TXDEL	1	RO	Transmit Data Path Delay Information Not supported by the GPHY. 0 _B NONE PHYs do not have this capability. 1 _B CAPABLE Minimum and maximum Tx data path delay available
RXDEL	0	RO	Receive Data Path Delay Information Not supported by the GPHY. 0 _B NONE PHYs do not have this capability. 1 _B CAPABLE Minimum and maximum Rx data path delay available

6.2 Standard PCS Registers

This section describes the PCS registers for MMD device 0x03.

Table 33 Registers Overview- Standard PCS Registers

Register Short Name	Register Long Name	Reset Value
PCS_CTRL1	PCS Control 1 (Register 3.0)	205C _H
PCS_STAT1	PCS Status 1 (Register 3.1)	0000 _H
PCS_DEVID1	PHY Identifier 1 (Register 3.2)	C133 _H
PCS_DEVID2	PHY Identifier 2 (Register 3.3)	5400 _H ¹⁾
PCS_SPEED_ABILITY	PCS Speed Ability (Register 3.4)	0040 _H
PCS_DIP1	PCS Devices in Package 1 (Register 3.5)	008B _H
PCS_DIP2	PCS Devices in Package 2 (Register 3.6)	C000 _H
PCS_CTRL2	PCS Control 2 (Register 3.7)	000A _H
PCS_STAT2	PCS Status 2 (Register 3.8)	9000 _H
PCS_PACKID1	PCS Package Identifier 1 (Register 3.14)	C133 _H
PCS_PACKID2	PCS Package Identifier 2 (Register 3.15)	5400 _H ¹⁾
PCS_EEE_CAP	PCS EEE Capability (Register 3.20)	0006 _H
PCS_EEE_CAP2	EEE Control and Capability 2 (Register 3.21)	0001 _H
PCS_EEE_WAKERR	PCS EEE Status Register 1 (Register 3.22)	0000 _H
PCS_2G5_STAT1	BASE-R and 10GBASE-T PCS Status 1 (Register 3.32)	0000 _H
PCS_2G5_STAT2	MULTIGBASE-T PCS Status 2 (Register 3.33)	0000 _H
PCS_TIMESYNC_CAP	PCS TimeSync Capability Register (Register 3.1800)	0000 _H

1) For the device specific reset value, see the Product and Package Naming table in the [Product Ordering Information](#) chapter.

6.2.1 PCS Register Descriptions

This section describes all the PCS registers in detail.

PCS Control 1 (Register 3.0)

IEEE Standard Register=3.0

PCS_CTRL1

PCS Control 1 (Register 3.0)

Reset Value

205C_H

15	14	13	12	11	10	9	7	6	5	2	1	0
RST	LOOPBACK	SSL	RES	LOW_POWER*	RXCKST	RES		SSM	SPEED_SEL		RES	
RW	RW	RW		RW	RW			RW		RW		

Field	Bits	Type	Description
RST	15	RW	Reset 0 _B Normal operation 1 _B PCS reset - Self-clearing
LOOPBACK	14	RW	Loopback 0 _B Disable loopback mode 1 _B Enable loopback mode
SSL	13	RW	Forced Speed Selection (LSB) This bit is used in conjunction with SPEED_SEL_LSB. The bit assignment order is: MSB LSB 00 _B 10 Mbps 01 _B 100 Mbps 10 _B 1000 Mbps 11 _B Bits [5:2] select the speed
LOW_POWER	11	RW	Low Power 0 _B Normal operation 1 _B Low-power mode
RXCKST	10	RW	Clock Stop Enable The MAC sets this bit to active to allow the GPHY to stop the clocking during the LPI_MODE. 0 _B The clock is not stoppable. 1 _B The GPHY stops the (X)GMII clock during LPI.
SSM	6	RW	Forced Speed Selection (MSB) This bit is used in conjunction with SPEED_SEL_MSB. The bit assignment order is: MSB LSB 00 _B 10 Mbps 01 _B 100 Mbps 10 _B 1000 Mbps 11 _B Bits [5:2] select the speed

Field	Bits	Type	Description (cont'd)
SPEED_SEL	5:2	RW	Forced Speed Selection Values 0 0 0 0 _B Unsupported, defaults to 2.5 Gbps 0 0 0 1 _B Unsupported, defaults to 2.5 Gbps 0 0 1 0 _B Unsupported, defaults to 2.5 Gbps 0 0 1 1 _B Unsupported, defaults to 2.5 Gbps 0 1 0 0 _B Unsupported, defaults to 2.5 Gbps 0 1 0 1 _B Reserved 0 1 1 1 _B 2.5 Gbps 1 1 x x _B Reserved

PCS Status 1 (Register 3.1)

IEEE Standard Register=3.1

PCS_STAT1
PCS Status 1 (Register 3.1)
Reset Value
0000_H

15	12	11	10	9	8	7	6	5	3	2	1	0
RES		TX_LP L*	RX_LP L*	TX_LP L*	RX_LP L*	FAUL T	TXCK ST	RES		PCS_ RX_*	LOW_ POW*	RES
		ro	ro	ro	ro	ro	ro			ro	ro	

Field	Bits	Type	Description
TX_LPI_RXD	11	RO	Tx LPI Received 0 _B LPI not received 1 _B Tx PCS received LPI
RX_LPI_RXD	10	RO	Rx LPI Received 0 _B LPI not received 1 _B Rx PCS received LPI
TX_LPI_INDICATION	9	RO	Tx LPI Indication 0 _B PCS is not currently receiving LPI. 1 _B Tx PCS is currently receiving LPI.
RX_LPI_INDICATION	8	RO	Rx LPI Indication 0 _B PCS is not currently receiving LPI. 1 _B Rx PCS is currently receiving LPI.
FAULT	7	RO	Fault 0 _B No fault condition detected 1 _B Fault condition detected
TXCKST	6	RO	Clock Stop Capable 0 _B The clock is not stoppable. 1 _B The MAC is allowed to stop the clock during LPI.
PCS_RX_LINK_STATUS	2	RO	PCS Receive Link Status 0 _B PCS receive link down 1 _B PCS receive link up
LOW_POWER_ABILITY	1	RO	Low Power Ability 0 _B PCS does not support low power mode. 1 _B PCS supports low power mode.

PHY Identifier 1 (Register 3.2)

IEEE Standard Register=3.2

PCS_DEVID1

PHY Identifier 1 (Register 3.2)

Reset Value

C133_H

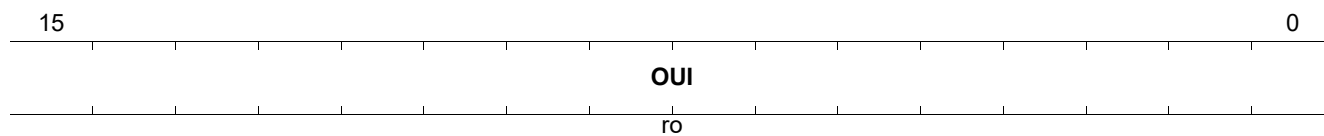

Field	Bits	Type	Description
OUI	15:0	RO	Organizationally Unique Identifier Bits 3:18

PHY Identifier 2 (Register 3.3)

Organizationally Unique Identifier Bits 19:24

IEEE Standard Register=3.3

PCS_DEVID2

PHY Identifier 2 (Register 3.3)

Reset Value

5400_H

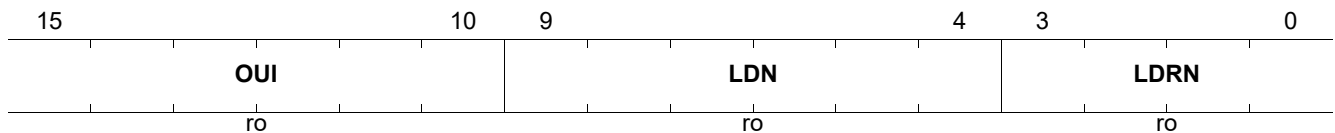

Field	Bits	Type	Description
OUI	15:10	RO	Organizationally Unique Identifier Bits 19:24
LDN	9:4	RO	Device Number Specifies the device number ¹⁾ to distinguish between several different products.
LDRN	3:0	RO	Device Revision Number Specifies the device revision number ¹⁾ to distinguish between several versions of this device.

1) For the device specific reset value, see the Product and Package Naming table in the [Product Ordering Information](#) chapter.

PCS Speed Ability (Register 3.4)

IEEE Standard Register=3.4

PCS_SPEED_ABILITY

Reset Value

PCS Speed Ability (Register 3.4)

0040_H

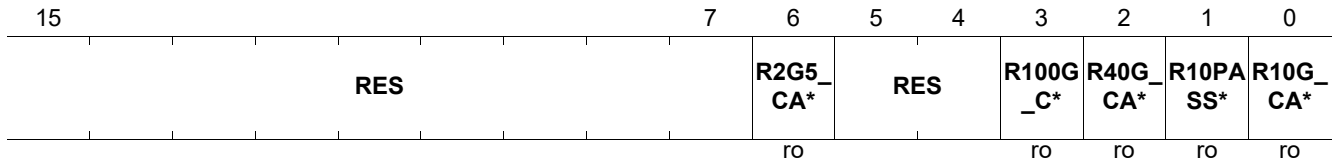

Field	Bits	Type	Description
R2G5_CAPABLE	6	RO	2G5 Capable This bit is always set to 1 _B because the PCS is capable of operating at 2.5 Gbps.
R100G_CAPABLE	3	RO	100G Capable 0 _B PCS is not capable of operating at 100 Gbps. 1 _B PCS is capable of operating at 100 Gbps.
R40G_CAPABLE	2	RO	40G Capable 0 _B PCS is not capable of operating at 40 Gbps. 1 _B PCS is capable of operating at 40 Gbps.
R10PASS_TS_2BASE_TL	1	RO	10PASS-TS/2BASE-TL Capable 0 _B PCS is not capable of operating as the 10P/2B PCS. 1 _B PCS is capable of operating as the 10P/2B PCS.
R10G_CAPABLE	0	RO	10G Capable 0 _B PCS is not capable of operating at 10 Gbps. 1 _B PCS is capable of operating at 10 Gbps.

PCS Devices in Package 1 (Register 3.5)

IEEE Standard Register=3.5

PCS_DIP1

PCS Devices in Package 1 (Register 3.5)

Reset Value

008B_H

15	12	11	10	9	8	7	6	5	4	3	2	1	0
RES		SEPA RAT*	SEP_P MA*	SEPA RAT*	SEPA RAT*	ANEG	TC	DTE_X S	PHY_ XS	PCS	WIS_P RE*	PMD_ PMA	CL22
ro		ro	ro	ro	ro	ro	ro	ro	ro	ro	ro	ro	ro

Field	Bits	Type	Description
RES	15:12	RO	Reserved Ignore on read
SEPARATED_PMA_4	11	RO	Separate PMA (4) 0 _B Separate PMA (4) not present in package 1 _B Separate PMA (4) present in package
SEP_PMA_3	10	RO	Separate PMA (3) 0 _B Separate PMA (3) not present in package 1 _B Separate PMA (3) present in package
SEPARATED_PMA_2	9	RO	Separate PMA (2) 0 _B Separate PMA (2) not present in package 1 _B Separate PMA (2) present in package
SEPARATED_PMA_1	8	RO	Separate PMA (1) 0 _B Separate PMA (1) not present in package 1 _B Separate PMA (1) present in package
ANEG	7	RO	Auto-Negotiation Present 0 _B Auto-negotiation not present in package 1 _B Auto-negotiation present in package
TC	6	RO	TC Present 0 _B TC not present in package 1 _B TC present in package
DTE_XS	5	RO	DTE XS Present 0 _B DTE XS not present in package 1 _B DTE XS present in package
PHY_XS	4	RO	PHY XS Present 0 _B PHY XS not present in package 1 _B PHY XS present in package
PCS	3	RO	PCS Present 0 _B PCS not present in package 1 _B PCS present in package
WIS_PRESENT	2	RO	WIS Present 0 _B WIS not present in package 1 _B WIS present in package

Field	Bits	Type	Description (cont'd)
PMD_PMA	1	RO	PMD/PMA Present 0 _B PMA/PMD not present in package 1 _B PMA/PMD present in package
CL22	0	RO	Clause 22 Registers Present 0 _B Clause 22 registers not present in package 1 _B Clause 22 registers present in package

PCS Control 2 (Register 3.7)

IEEE Standard Register=3.7

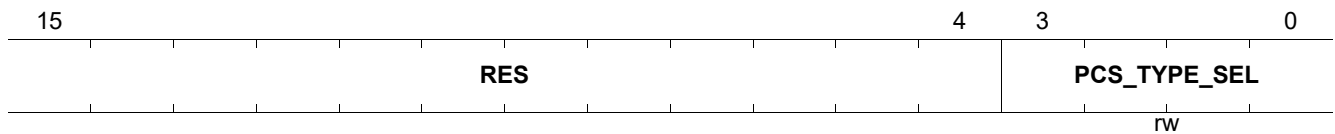
PCS_CTRL2
PCS Control 2 (Register 3.7)
Reset Value
000A_H

Field	Bits	Type	Description
PCS_TYPE_SEL	3:0	RW	PCS Type Selection 0000 _B Not supported, defaults to 2.5 Gbps 0001 _B Not supported, defaults to 2.5 Gbps 0010 _B Not supported, defaults to 2.5 Gbps 0011 _B Not supported, defaults to 2.5 Gbps 0100 _B Not supported, defaults to 2.5 Gbps 0101 _B Not supported, defaults to 2.5 Gbps 0110 _B Not supported, defaults to 2.5 Gbps 0111 _B Not supported, defaults to 2.5 Gbps 1000 _B Reserved 1001 _B Not supported, defaults to 2.5 Gbps 1010 _B Select 2.5 Gbps PCS type (Default) 1011 _B Not supported, defaults to 2.5 Gbps 1100 _B Not supported, defaults to 2.5 Gbps 1101 _B Not supported, defaults to 2.5 Gbps 1110 _B Reserved 1111 _B Reserved

PCS Status 2 (Register 3.8)

IEEE Standard Register=3.8

PCS_STAT2

PCS Status 2 (Register 3.8)

Reset Value

9000_H

15	14	13	12	11	10	9	6	5	4	3	2	1	0
DEVICE_PRE SENT	RES	R2G5_ CA*	TX_FA ULT	RX_F AULT	RES			R100G BA*	R40G BAS*	R10G BAS*	R10G BAS*	R10G BAS*	R10G BAS*
ro		ro	ro	ro				ro	ro	ro	ro	ro	ro

Field	Bits	Type	Description
DEVICE_PRE SENT	15:14	RO	Device Present 00 _B No device responding at this address 01 _B No device responding at this address 10 _B Device responding at this address 11 _B No device responding at this address
R2G5_CAPAB LE	12	RO	2G5BASE-T Capable 0 _B PCS is not able to support 2.5GBASE-T PCS type. 1 _B PCS is able to support 2.5GBASE-T PCS type.
TX_FAULT	11	RO	Transmit Fault 0 _B No fault condition on transmit path 1 _B Fault condition on transmit path
RX_FAULT	10	RO	Receive Fault 0 _B No fault condition on receive path 1 _B Fault condition on receive path
R100GBASE_ R_CAPABLE	5	RO	100GBASE-R Capable 0 _B PCS is not able to support 100GBASE-R PCS type. 1 _B PCS is able to support 100GBASE-R PCS type.
R40GBASE_R _CAPABLE	4	RO	40GBASE-R Capable 0 _B PCS is not able to support 40GBASE-R PCS type. 1 _B PCS is able to support 40GBASE-R PCS type.
R10GBASE_T _CAPABLE	3	RO	10GBASE-T Capable 0 _B PCS is not able to support 10GBASE-T PCS type. 1 _B PCS is able to support 10GBASE-T PCS type.
R10GBASE_W _CAPABLE	2	RO	10GBASE-W Capable 0 _B PCS is not able to support 10GBASE-W PCS type. 1 _B PCS is able to support 10GBASE-W PCS type.
R10GBASE_X _CAPABLE	1	RO	10GBASE-X Capable 0 _B PCS is not able to support 10GBASE-X PCS type. 1 _B PCS is able to support 10GBASE-X PCS type.
R10GBASE_R _CAPABLE	0	RO	10GBASE-R Capable 0 _B PCS is not able to support 10GBASE-R PCS types. 1 _B PCS is able to support 10GBASE-R PCS types.

PCS Package Identifier 1 (Register 3.14)

IEEE Standard Register=3.14

PCS_PACKID1

Reset Value

PCS Package Identifier 1 (Register 3.14)

C133_H

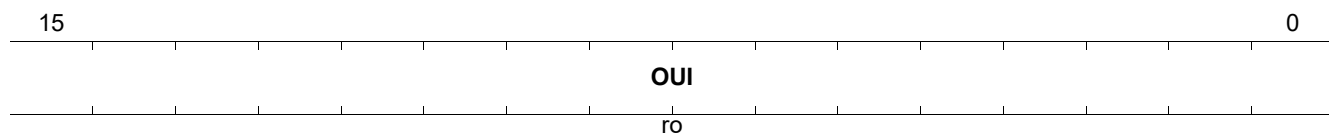

Field	Bits	Type	Description
OUI	15:0	RO	Organizationally Unique Identifier Bits 3:18

PCS Package Identifier 2 (Register 3.15)

IEEE Standard Register=3.15

PCS_PACKID2

PCS Package Identifier 2 (Register 3.15)

Reset Value

5400_H

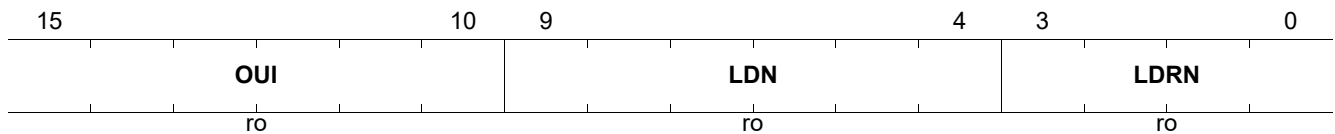

Field	Bits	Type	Description
OUI	15:10	RO	Organizationally Unique Identifier Bits 19:24
LDN	9:4	RO	Device Number Specifies the device number ¹⁾ to distinguish between several different products.
LDRN	3:0	RO	Device Revision Number Specifies the device revision number to distinguish between several versions of this device.

1) For the device specific reset value, see the Product and Package Naming table in the [Product Ordering Information](#) chapter.

PCS EEE Capability (Register 3.20)

IEEE Standard Register=3.20

PCS_EEE_CAP

PCS EEE Capability (Register 3.20)

Reset Value

0006_H

15	7	6	5	4	3	2	1	0				
RES						R10G BAS*	R10G BAS*	R1000 BA*	R10G BAS*	R1000 BA*	R100B AS*	RES
						ro	ro	ro	ro	ro	ro	

Field	Bits	Type	Description
R10GBASE_K R_EEE	6	RO	10GBASE-KR EEE 0 _B EEE is not supported for 10GBASE-KR. 1 _B EEE is supported for 10GBASE-KR.
R10GBASE_K X4_EEE	5	RO	10GBASE-KX4 EEE 0 _B EEE is not supported for 10GBASE-KX4. 1 _B EEE is supported for 10GBASE-KX4.
R1000BASE_ KX_EEE	4	RO	1000BASE-KX EEE 0 _B EEE is not supported for 1000BASE-KX. 1 _B EEE is supported for 1000BASE-KX.
R10GBASE_T _EEE	3	RO	10GBASE-T EEE 0 _B EEE is not supported for 10GBASE-T. 1 _B EEE is supported for 10GBASE-T.
R1000BASE_T _EEE	2	RO	1000BASE-T EEE 0 _B EEE is not supported for 1000BASE-T. 1 _B EEE is supported for 1000BASE-T.
R100BASE_T X_EEE	1	RO	100BASE-TX EEE 0 _B EEE is not supported for 100BASE-TX. 1 _B EEE is supported for 100BASE-TX.

EEE Control and Capability 2 (Register 3.21)

Read only. Write from the STA has no effect.

IEEE Standard Register=3.21

PCS_EEE_CAP2

Reset Value

EEE Control and Capability 2 (Register 3.21)

0001_H



Field	Bits	Type	Description
RES	15:2	RO	Reserved Value always 0.
AB5GEEE	1	RO	EEE Supported for 5GBASE-T 0 _B UNABLE EEE is not supported for 5GBASE-T. 1 _B ABLE EEE is supported for 5GBASE-T.
AB2G5EEE	0	RO	EEE Supported for 2.5GBASE-T 0 _B UNABLE EEE is not supported for 2.5GBASE-T. 1 _B ABLE EEE is supported for 2.5GBASE-T.

PCS EEE Status Register 1 (Register 3.22)

IEEE Standard Register=3.22

PCS_EEE_WAKERR

PCS EEE Status Register 1 (Register 3.22)

Reset Value

0000_H

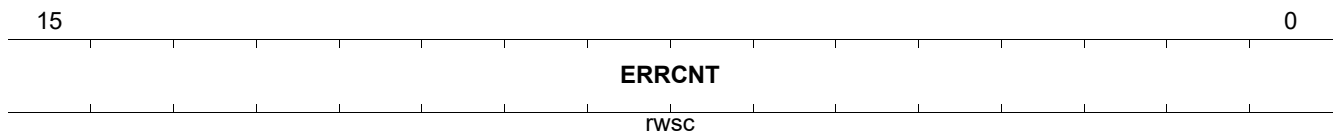

Field	Bits	Type	Description
ERRCNT	15:0	RWSC	<p>EEE Wake Error Counter</p> <p>This is a 16-bit saturating counter indicating the number of times the GPHY PHY fails to wake up within the EEE time. This counter is cleared upon read from the STA.</p>

BASE-R and 10GBASE-T PCS Status 1 (Register 3.32)

IEEE Standard Register=3.32

PCS_2G5_STAT1

Reset Value

BASE-R and 10GBASE-T PCS Status 1 (Register 3.32)

0000_H

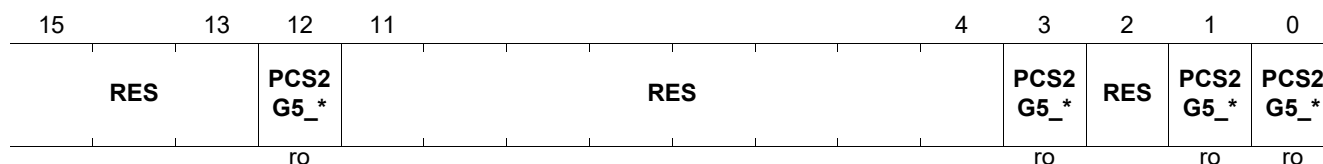

Field	Bits	Type	Description
PCS2G5_LINK_STATUS	12	RO	BASE-R and 10GBase-T Rx Link Status 0 _B 2G5 PCS receive link down 1 _B 2G5 PCS receive link up
PCS2G5_PAT_TEST_AB	3	RO	PRBS9 Pattern Testing Ability 0 _B PCS is not able to support PRBS9 pattern testing. 1 _B PCS is able to support PRBS9 pattern testing.
PCS2G5_HI_BER	1	RO	PCS 2G5 High BER This bit is a direct reflection of the state of the hi_lfer variable in 126.3.6.2.2 for 2.5GBASE-T. A latch high view of this status is reflected in MDIO register 3.33.14. 0 _B The 64B/65B receiver detects a BER below 10 ⁻⁴ . 1 _B The 64B/65B receiver detects a BER above or equal to 10 ⁻⁴ .
PCS2G5_BLOCK_LOCK	0	RO	PCS 2G5 Block Lock 0 _B 64B/65B receiver does not have block lock. 1 _B 64B/65B receiver has block lock.

MULTIGBASE-T PCS Status 2 (Register 3.33)

PCS_2G5_STAT2 Reset Value
MULTIGBASE-T PCS Status 2 (Register 3.33) 0000_H

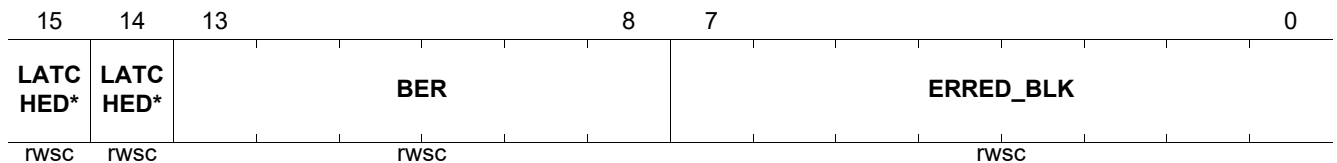

Field	Bits	Type	Description
LATCHED_BLOCK_LOCK	15	RWSC	Latched Block Lock 0 _B PCS 2G5 does not have block lock. 1 _B PCS 2G5 has block lock.
LATCHED_HIGH_BER	14	RWSC	Latched High BER 0 _B PCS 2G5 did not report a high BER. 1 _B PCS 2G5 reported a high BER.
BER	13:8	RWSC	BER BER counter
ERRED_BLOCKS	7:0	RWSC	Errored Blocks Errored blocks counter

PCS TimeSync Capability Register (Register 3.1800)

IEEE Standard Register=3.1800

PCS_TIMESYNC_CAP

PCS TimeSync Capability Register (Register 3.1800)

Reset Value

0000_H



Field	Bits	Type	Description
TIMESYNC_TX_PATH_DATA_DELAY	1	RO	<p>TimeSync Transmit Path Data Delay</p> <p>0_B PCS does not provide information on transmit path data delay. For the GPHY, the value is always 0.</p> <p>1_B PCS provides information on transmit path data delay in registers 3.1801 through 3.1804.</p>
TIMESYNC_RX_PATH_DATA_DELAY	0	RO	<p>TimeSync Receive Path Data Delay</p> <p>0_B PCS does not provide information on receive path data delay. For the GPHY, the value is always 0.</p> <p>1_B PCS provides information on receive path data delay in registers 3.1805 through 3.1808.</p>

6.3 Standard Auto-Negotiation Registers for MMD=0x07

This register file contains the auto-negotiation registers for MMD device 0x07.

Table 34 Registers Overview- Standard Auto-Negotiation Registers

Register Short Name	Register Long Name	Reset Value
ANEG_CTRL	Auto-Negotiation Control (Register 7.0)	3000 _H
ANEG_STAT	Auto-Negotiation Status (Register 7.1)	0008 _H
ANEG_DEVID1	PHY Identifier 1 (Register 7.2)	C133 _H
ANEG_DEVID2	PHY Identifier 2 (Register 7.3)	5400 _H ¹⁾
ANEG_DIP1	Device in Package 1 (Register 7.5)	008B _H
ANEG_DIP2	Device in Package 2 (Register 7.6)	C000 _H
ANEG_PACKID1	AN Package Identifier (Register 7.14)	C133 _H
ANEG_PACKID2	AN Package Identifier (Register 7.15)	5400 _H ¹⁾
ANEG_ADV	ANEG Adv. for GPHY (Register 7.16)	9DE1 _H
ANEG_LP_BP_AB	AN Link Partner Base Page Ability (Register 7.19)	0DE0 _H
ANEG_XNP_TX1	ANEG Local Dev XNP TX1 (Register 7.22)	0001 _H
ANEG_XNP_TX2	ANEG Local Dev XNP TX2 (Register 7.23)	0000 _H
ANEG_XNP_TX3	ANEG Local Dev XNP TX3 (Register 7.24)	0000 _H
ANEG_LP_XNP_AB1	ANEG Link Partner XNP RX (Register 7.25)	0000 _H
ANEG_LP_XNP_AB2	ANEG Link Partner XNP RX (Register 7.26)	0000 _H
ANEG_LP_XNP_AB3	ANEG Link Partner XNP RX (Register 7.27)	0000 _H
ANEG_MGBT_AN_CTRL	MULTI GBT AN Control (Register 7.32)	0082 _H
ANEG_MGBT_AN_STA	MultiGBASE-T AN Status (Register 7.33)	0000 _H
ANEG_EEE_AN_ADV1	EEE Advertisement 1 (Register 7.60)	0006 _H
ANEG_EEE_AN_LPAB1	EEE Link Partner Ability 1 (Register 7.61)	0000 _H
ANEG_EEE_AN_ADV2	EEE Advertisement 2 (Register 7.62)	0001 _H
ANEG_EEE_LP_AB2	EEE Link Partner Ability 2 (Register 7.63)	0001 _H
ANEG_MGBT_AN_CTRL2	MGBT ANEG Control 2 (Register 7.64)	0008 _H

1) For the device specific reset value, see the Product and Package Naming table in the [Product Ordering Information](#) chapter.

6.3.1 ANEG Register Descriptions

This section describes all the ANEG registers in detail.

Auto-Negotiation Control (Register 7.0)

The register controls the main function of auto-negotiation as defined in Clause 45. Refer to IEEE 802.3 45.2.7.1. This register mirrors register STD_CTRL from Clause 22.

IEEE Standard Register=7.0

ANEG_CTRL

Reset Value

Auto-Negotiation Control (Register 7.0)

3000_H

15	14	13	12	11	10	9	8				0
RST	RES3	XNP	ANEG_EN*	RES2		ANEG_RE*	RES1				
RW	RO	RW	RW	RO		RW	RO				

Field	Bits	Type	Description
RST	15	RW	Reset This bit resets the entire PHY to its default state. Active links are terminated. This is a self-clearing bit. The GPHY firmware sets the bit to 0 via the hardware when the reset is completed. 0 _B NORMAL Normal GPHY operation 1 _B RESET GPHY reset
RES3	14	RO	Reserved Value always 0, writes ignored.
XNP	13	RW	Extended Next Page Control 0 _B ZERO Extended next page is disabled. 1 _B ONE Extended next page is enabled.
ANEG_ENAB	12	RW	Auto-Negotiation Enable This bit enables the ANEG process to determine the link configuration. Bit 7.0.12 is a copy of bit 0.12 in register 0 (STD_CTRL). 0 _B ZERO ANEG process is disabled. 1 _B ONE ANEG process is enabled.
RES2	11:10	RO	Reserved Value always zero, writes ignored.
ANEG_RESTART	9	RW	Restart Auto-Negotiation The ANEG process is restarted by setting bit 7.0.9 to 1. Bit 7.0.9 is a mirror of bit 0.9 in register 0 (STD_CTRL). Completion of ANEG is indicated in bit 0.1.5 and 7.1.5. 0 _B ZERO Normal operation 1 _B RESTART Restarts ANEG process.
RES1	8:0	RO	Reserved Value always 0, writes ignored.

Auto-Negotiation Status (Register 7.1)

All the bits in the ANEG_STA status register are read only and correspond to the outcome or current status of the auto-negotiation process.

IEEE Standard Register=7.1

ANEG_STAT

Auto-Negotiation Status (Register 7.1)

Reset Value

0008_H

15	10	9	8	7	6	5	4	3	2	1	0	
RES3			PDF	RES2	XNPS	PR	ANEG _CO*	ANEG _RF	ANEG _AB*	LINKS TA	RES1	LP_A NEG*
ro			ro	ro	ro	ro	ro	rosc	ro	ro	ro	ro

Field	Bits	Type	Description
RES3	15:10	RO	Reserved Value always zero, writes ignored.
PDF	9	RO	Parallel Detection Fault 0 _B NOFAULT No fault detected 1 _B FAULT Fault detected via the parallel mechanism
RES2	8	RO	Reserved Value always 0, writes ignored.
XNPS	7	RO	Extended Next Page Status When set to 1 _B , bit 7.1.7 indicates that both the GPHY and the link partner confirmed support for extended next page. When set to 0 _B , bit 7.1.7 indicates that the extended next page feature is not used. 0 _B ZERO Extended next page is not allowed. 1 _B ONE Extended next page format is used.
PR	6	RO	Page Received The Page Received bit (7.1.6) is set to 1 _B to indicate that a new link codeword was received and stored in the AN LP Base Page ability registers 7.19 or AN LP XNP ability registers 7.25 to 7.27. 0 _B ZERO No page received 1 _B ONE Page received
ANEG_COMP LETE	5	RO	Auto-Negotiation Complete When read as a 1, bit 7.1.5 indicates that the ANEG process was completed and that the contents of the ANEG registers 7.16 and 7.19 are valid. When read as a 0, bit 7.1.5 indicates that the ANEG process was not completed and that the contents of the 7.19, 7.22 through 7.27, and 7.33 registers are as defined by the current state of the ANEG protocol, or as written by manual configuration. 0 _B ZERO ANEG process not completed 1 _B ONE ANEG process completed

Field	Bits	Type	Description (cont'd)
ANEG_RF	4	ROSC	<p>Remote Fault When read as 1, bit 7.1.4 indicates that a remote fault condition was detected. Bit 7.1.4 is a copy of bit 1.4 in register 1, device 0.</p> <p>0_B NORMAL No remote fault condition detected 1_B FAULT Remote fault condition detected</p>
ANEG_ABLE	3	RO	<p>Auto-Negotiation Ability Bit 7.1.3 is a copy of bit 1.3 in register 1. This is the ANEG ability of the GPHY.</p> <p>0_B UNABLE PHY is not able to perform ANEG. 1_B ABLE PHY is able to perform ANEG.</p>
LINKSTA	2	RO	<p>Link Status When read as 1_B, bit 7.1.2 indicates that the PMA/PMD determined that a valid link is established. This bit is a duplicate of the PMA/PMD link status bit in 1.1.2. This bit latches low so it does not represent the current status, but is used to indicate link drop since the last read from the management interface. Reading this bit from the MDIO resets the bit to the current value of the link.</p> <p>0_B DOWN Link is down. 1_B UP Link is up.</p>
RES1	1	RO	<p>Reserved Value always 0, write ignored.</p>
LP_ANEG_ABLE	0	RO	<p>Link Partner Auto-Negotiation Ability 0_B UNABLE Link partner is not capable of ANEG. 1_B ABLE Link partner is capable of ANEG.</p>

PHY Identifier 1 (Register 7.2)

ANEG_DEVID1 **Reset Value**
PHY Identifier 1 (Register 7.2) **C133_H**

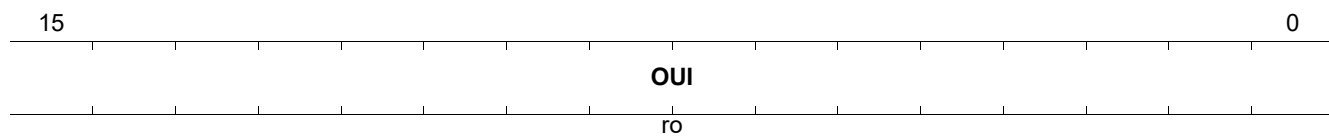

Field	Bits	Type	Description
OUI	15:0	RO	Organizationally Unique Identifier

PHY Identifier 2 (Register 7.3)

Organizationally Unique Identifier
IEEE Standard Register=7.3

ANEG_DEVID2

PHY Identifier 2 (Register 7.3)

Reset Value

5400_H



Field	Bits	Type	Description
OUI	15:10	RO	Organizationally Unique Identifier
LDN	9:4	RO	Device Number Specifies the device number ¹⁾ to distinguish between several different products.
LDRN	3:0	RO	Device Revision Number Specifies the device revision number ¹⁾ to distinguish between several versions of this device.

1) For the device specific reset value, see the Product and Package Naming table in the [Product Ordering Information](#) chapter.

Device in Package 1 (Register 7.5)

IEEE Standard Register=7.5

ANEG_DIP1

Device in Package 1 (Register 7.5)

Reset Value

008B_H

15			12	11	10	9	8	7	6	5	4	3	2	1	0
RES				PMA4	PMA3	PMA2	PMA1	ANEG	TC	DTEX S	PHYX S	PCS	WIS	PMAP MD	CL22
				ro	ro	ro	ro	ro	ro	ro	ro	ro	ro	ro	ro

Field	Bits	Type	Description
RES	15:12	RO	Reserved Ignore on read.
PMA4	11	RO	Separate PMA4 Present in Package 0 _B ABSENT Separate PMA4 not present in package 1 _B PRESENT Separate PMA4 present in package
PMA3	10	RO	Separate PMA3 Present in Package 0 _B ABSENT Separate PMA3 not present in package 1 _B PRESENT Separate PMA3 present in package
PMA2	9	RO	Separate PMA2 Present in Package 0 _B ABSENT Separate PMA2 not present in package 1 _B PRESENT Separate PMA2 present in package
PMA1	8	RO	Separate PMA1 Present in Package 0 _B ABSENT Separate PMA1 not present in package 1 _B PRESENT Separate PMA1 present in package
ANEG	7	RO	Auto-Negotiation Present in Package 0 _B ABSENT ANEG not present in package 1 _B PRESENT ANEG present in package
TC	6	RO	TC Present in Package 0 _B ABSENT TC registers not present in package 1 _B PRESENT TC registers present in package
DTEXS	5	RO	DTE XS Present in Package 0 _B ABSENT DTE XS registers not present in package 1 _B PRESENT DTE XS registers present in package
PHYXS	4	RO	PHYXS Present in Package 0 _B ABSENT PHYXS registers not present in package 1 _B PRESENT PHYXS registers present in package
PCS	3	RO	PCS Present in Package 0 _B ABSENT PCS registers not present in package 1 _B PRESENT PCS registers present in package
WIS	2	RO	WIS Present in Package 0 _B ABSENT WIS registers present in package 1 _B PRESENT WIS registers present in package

Field	Bits	Type	Description (cont'd)
PMAPMD	1	RO	PMA PMD Present in Package
			0 _B ABSENT PMA PMD registers not present in package
			1 _B PRESENT PMA PMD registers present in package
CL22	0	RO	Clause 22 Register Present in Package
			0 _B ABSENT Clause 22 registers no present in package
			1 _B PRESENT Clause 22 registers present in package

Device in Package 2 (Register 7.6)

IEEE Standard Register=7.6

ANEG_DIP2

Reset Value

Device in Package 2 (Register 7.6)

C000_H

15	14	13	12								0
VSPE C2	VSPE C1	CL22E XT	RES								
ro	ro	ro	ro								

Field	Bits	Type	Description
VSPEC2	15	RO	Vendor Specific Device 2 Present in Package 0 _B ABSENT Vendor Specific Device 2 not present in package 1 _B PRESENT Vendor Specific Device 2 present in package
VSPEC1	14	RO	Vendor Specific Device 1 Present in Package 0 _B ABSENT Vendor Specific Device 1 not present in package 1 _B PRESENT Vendor Specific Device 1 present in package
CL22EXT	13	RO	Clause 22 Extension Present in Package 0 _B ABSENT Clause 22 extension not present in package 1 _B PRESENT Clause 22 extension present in package
RES	12:0	RO	Reserved Ignore on read.

AN Package Identifier (Register 7.14)

IEEE Standard Register=7.14

ANEG_PACKID1

Reset Value

AN Package Identifier (Register 7.14)

C133_H

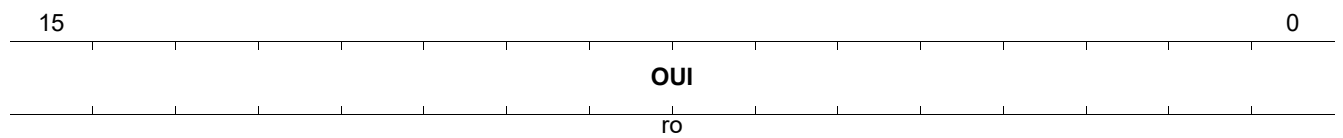

Field	Bits	Type	Description
OUI	15:0	RO	Organizationally Unique Identifier Bits 3:18

AN Package Identifier (Register 7.15)

IEEE Standard Register=7.15

ANEG_PACKID2

AN Package Identifier (Register 7.15)

Reset Value

5400_H

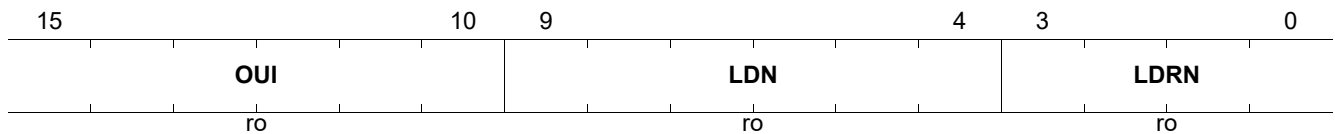

Field	Bits	Type	Description
OUI	15:10	RO	Organizationally Unique Identifier Bits 19:24
LDN	9:4	RO	Device Number Specifies the device number ¹⁾ to distinguish between several different products.
LDRN	3:0	RO	Device Revision Number Specifies the device revision number ¹⁾ to distinguish between several versions of this device.

1) For the device specific reset value, see the Product and Package Naming table in the [Product Ordering Information](#) chapter.

ANEG Adv. for GPHY (Register 7.16)

This register is a copy of the ANEG advertisement register (Register 4). A read to the AN advertisement register (7.16) reports the value of the ANEG advertisement register (Register 4). Writes to the AN advertisement register (7.16) cause a write to occur to the ANEG advertisement register (Register 4).

IEEE Standard Register=7.16

ANEG_ADV

ANEG Adv. for GPHY (Register 7.16)

Reset Value

9DE1_H

15	14	13	12	11			5	4		0
NP	RES	RF	XNP	TAF				SF		
RW	RO	RW	RW	RW				RW		

Field	Bits	Type	Description
NP	15	RW	Next Page Able 0 _B INACTIVE No next page allowed. 1 _B ACTIVE Additional next page(s) to follow.
RES	14	RO	Reserved Write as zero, ignore on read.
RF	13	RW	Remote Fault The remote fault bit allows indication of a fault to the link partner. Refer to IEEE 802.3 28.2.1.2.4.
XNP	12	RW	Transmission of Extended Next Pages Indicates that the GPHY is able to transmit extended next pages. 0 _B UNABLE GPHY is XNP unable. 1 _B ABLE GPHY is XNP able.
TAF	11:5	RW	Technology Ability Field The technology ability field is an 8-bit wide field containing information indicating supported technologies. The GPHY supports 10BASE-T (half- and full-duplex), 100BASE-TX (half- and full-duplex), and both symmetric and asymmetric PAUSE. 40 _H PS_ASYM Advertises asymmetric pause 20 _H PS_SYM Advertises symmetric pause 10 _H DBT4 Advertises 100BASE-T4 08 _H DBT_FDX Advertises 100BASE-TX full-duplex 04 _H DBT_HDX Advertises 100BASE-TX half-duplex 02 _H XBT_FDX Advertises 10BASE-T full-duplex 01 _H XBT_HDX Advertises 10BASE-T half-duplex
SF	4:0	RW	Selector Field This field is always set to 00001 _B because the GPHY only supports the 802.3 Ethernet standard. 00001 _B IEEE8023 IEEE 802.3 technology.

AN Link Partner Base Page Ability (Register 7.19)

Register 7.19 is a copy of register 5 from Clause 28. It contains the Base Page received from the link partner. All of the bits in the AN LP Base Page Ability register are read only.

IEEE Standard Register=7.19

ANEG_LP_BP_AB

Reset Value

AN Link Partner Base Page Ability (Register 7.19)

0DE0_H

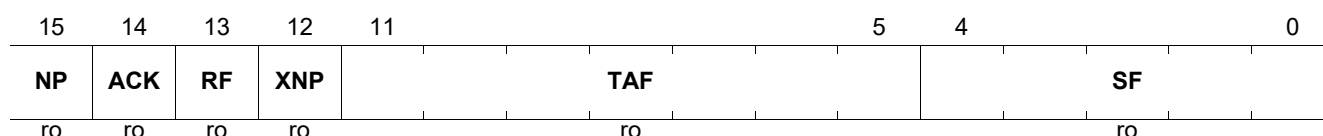

Field	Bits	Type	Description
NP	15	RO	Link Partner Next Page Next page request indication from the link partner. 0 _B INACTIVE No next page to follow 1 _B ACTIVE Additional next page to follow
ACK	14	RO	Link Partner Acknowledge Acknowledgment indication from the link partner's link code word. 0 _B INACTIVE Device did not successfully receive its link partner's link code word. 1 _B ACTIVE Device successfully received its link partner's link code word.
RF	13	RO	Link Partner Remote Fault Remote fault indication from the link partner. 0 _B NONE Remote fault is not indicated by the link partner. 1 _B FAULT Remote fault is indicated by the link partner.
XNP	12	RO	Link Partner XNP Ability 0 _B UNABLE Link partner is not XNP able. 1 _B ABLE Link partner is XNP able.
TAF	11:5	RO	Technology Ability Field These bits indicate the link partner's supported technologies received in the Base Page. 40 _H PS_ASYM Advertises asymmetric pause 20 _H PS_SYM Advertises symmetric pause 10 _H DBT4 Advertises 100BASE-T4 08 _H DBT_FDX Advertises 100BASE-TX full-duplex 04 _H DBT_HDX Advertises 100BASE-TX half-duplex 02 _H XBT_FDX Advertises 10BASE-T full-duplex 01 _H XBT_HDX Advertises 10BASE-T half-duplex

Field	Bits	Type	Description (cont'd)
SF	4:0	RO	<p>Link Partner Selector Field</p> <p>This selector field represents one of the 32 possible messages with encoding definitions defined in IEEE 802.3 Annex 28A.</p> <p>00_H Reserved</p> <p>01_H IEEE 802.3</p> <p>02_H IEEE 802.9 ISLAN-16T</p> <p>03_H IEEE 802.5</p> <p>04_H IEEE 1394</p> <p>05_H Reserved</p> <p>...</p> <p>1F_H Reserved</p>

ANEG Local Dev XNP TX1 (Register 7.22)

ANEG_XNP_TX1 **Reset Value**
0001_H
ANEG Local Dev XNP TX1 (Register 7.22)

	15	14	13	12	11	10											0
	NP	RES	MP	ACK2	TOGG		MCF										
	rw	ro	rw	rw	ro		rw										

Field	Bits	Type	Description
NP	15	RW	Next Page When the NP bit is set, the GPHY requests to transmit one additional page. The next page transmission ends when both ends of a link segment set their next page bits to logic 0, indicating that neither has anything additional to transmit. 0 _B INACTIVE No next page to follow. 1 _B ACTIVE Additional next page(s) to follow.
RES	14	RO	Reserved Write as 0, ignore on read.
MP	13	RW	Message Page Message Page (MP) is used by the next page function to differentiate a MP from an UP. Only MPs are used by the GPHY. 0 _B UNFOR Unformatted Page 1 _B MESSG Message Page
ACK2	12	RW	Acknowledge 2 Not used during GPHY ANEG. 0 _B INACTIVE Device does not comply with message. 1 _B ACTIVE Device complies with message.
TOGG	11	RO	Toggle The Toggle bit is used to ensure proper synchronization between the GPHY and the link partner. 0 _B ZERO Previous value of the Tx LCW was 1 _B . 1 _B ONE Previous value of the Tx LCW was 0 _B .

Field	Bits	Type	Description (cont'd)
MCF	10:0	RW	<p>Message Code Field</p> <p>When the Message Page bit is set to 1_B (7.16.1), this field is the Message Code Field of a message page used in a next page exchange. The message codes are described in IEEE 802.3 Appendix 28C. This is used to indicate the type of message in UCF1 and UCF2.</p> <p>00_H Reserved 01_H Null message 02_H One Unformatted Page (UP) with TAF follows 03_H Two UPs with TAF follows 04_H Remote fault details message 05_H OUI message 06_H PHY ID message 07_H 100BASE-T2 message 08_H 1000BASE-T message 09_H MULTIGBASE-T message 0A_H EEE technology capability follows in next UP 0B_H OUI XNP</p>

ANEG Local Dev XNP TX2 (Register 7.23)

Unformatted code field 1 contains seed information and advertises support of 1 GBT full-duplex and half-duplex. Refer to 28.2.3.4.

IEEE Standard Register=7.23

ANEG_XNP_TX2

Reset Value

ANEG Local Dev XNP TX2 (Register 7.23)

0000_H

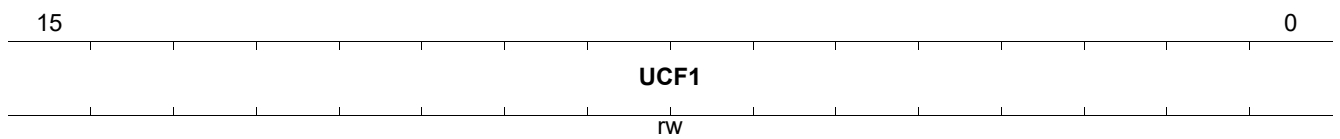

Field	Bits	Type	Description
UCF1	15:0	RW	Unformatted Code Field 1 Transmits the master-slave seed bit to facilitate ANEG resolution, port type, and duplex capability.

ANEG Local Dev XNP TX3 (Register 7.24)

Unformatted code field 2 - Register 7.24

Refer to 28.2.3.4.

IEEE Standard Register=7.24

ANEG_XNP_TX3

Reset Value

ANEG Local Dev XNP TX3 (Register 7.24)

0000_H

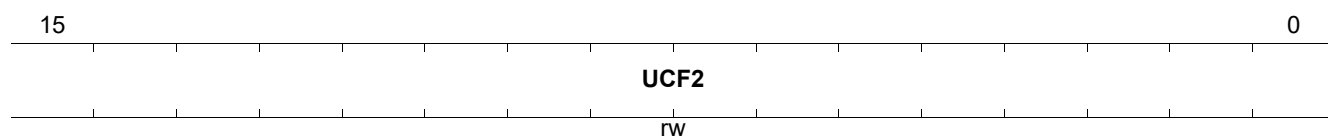

Field	Bits	Type	Description
UCF2	15:0	RW	Unformatted Code Field 2 2.5 GBASE-T ability is advertised by default.

ANEG Link Partner XNP RX (Register 7.25)

IEEE Standard Register=7.25

ANEG_LP_XNP_AB1

ANEG Link Partner XNP RX (Register 7.25)

Reset Value

0000_H

15	14	13	12	11	10					0
NP	ACK	MP	ACK2	TOGG	MCF					
ro	ro	ro	ro	ro	ro					

Field	Bits	Type	Description
NP	15	RO	Link Partner Next Page Refer to 28.2.3.4.3. The NP bit is used by the next page function to indicate whether or not this is the last next page to be transmitted. 0 _B INACTIVE Last page 1 _B ACTIVE Additional next page(s) to follow
ACK	14	RO	Link Partner Acknowledge As defined in 28.2.1.2.5. The Acknowledge (Ack) bit is used by the ANEG function to indicate that the GPHY successfully received its link partner's link codeword.
MP	13	RO	Link Partner Message Page Indicates that the content of MCF is either an unformatted page or a formatted message. 0 _B UNFOR Unformatted page 1 _B MESSG Message page
ACK2	12	RO	Link Partner Acknowledge 2 0 _B INACTIVE Device is unable to comply with message. 1 _B ACTIVE Device complies with message.
TOGG	11	RO	Link Partner Toggle This bit is set to the opposite of the TOGG bit in the previous page. 0 _B ZERO Previous value of the TX LCW was 1 _B . 1 _B ONE Previous value of the TX LCW was 0 _B .
MCF	10:0	RO	Link Partner Message Code Field This field indicates the type of Message Code. 009 _H MC_2G5BT Message code for 2.5GBASE-T

ANEG Link Partner XNP RX (Register 7.26)

IEEE Standard Register=7.26

ANEG_LP_XNP_AB2

ANEG Link Partner XNP RX (Register 7.26)

Reset Value

0000_H

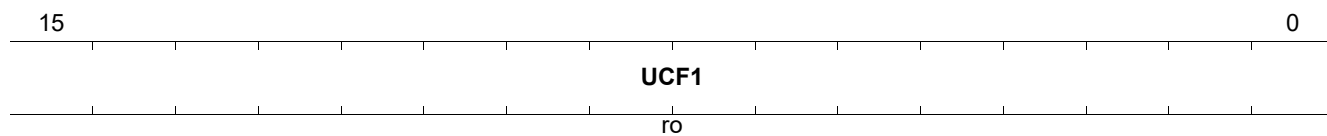

Field	Bits	Type	Description
UCF1	15:0	RO	Unformatted Code Field 1 Refer to 28.2.3.4.

ANEG Link Partner XNP RX (Register 7.27)

IEEE Standard Register=7.27

ANEG_LP_XNP_AB3

ANEG Link Partner XNP RX (Register 7.27)

Reset Value

0000_H

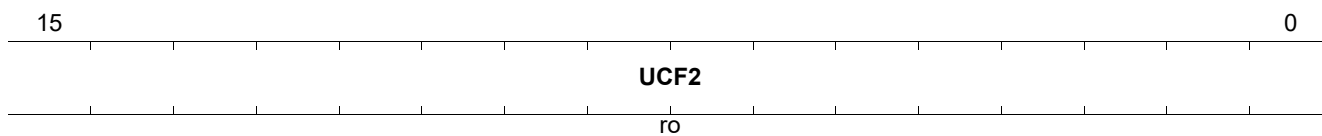

Field	Bits	Type	Description
UCF2	15:0	RO	Unformatted Code Field 2 Refer to 28.2.3.4.

MULTI GBT AN Control Register (Register 7.32)

This register advertises the GPHY capabilities.

IEEE Standard Register=7.32

ANEG_MGBT_AN_CTRL
Reset Value
MULTI GBT AN Control Register (Register 7.32)
0082_H

15	14	13	12	11		9	8	7	6	5	4	3	2	1	0
MS_M AN_*	MSCV	PT	AB_10 GBT		RES2		AB_5 GBT	AB_2 G5BT	FR_5G BT	FR_2G 5BT		RES1	LDPM A	FR	LDL
rw	rw	rw	ro		ro		ro	rw	ro	rw		ro	rw	rw	rw

Field	Bits	Type	Description
MS_MAN_EN	15	RW	Master Slave Manual Config Enable 0 _B ANEG ANEG is used to determine the master-slave selection. 1 _B MAN Manual configuration. The MSCV bit determines the master-slave selection.
MSCV	14	RW	Master Slave Config Value 0 _B SLAVE Manual set to SLAVE 1 _B MASTER Manual set to MASTER
PT	13	RW	Port Type 0 _B MASTER Preference as Master - single port device 1 _B SLAVE Preference as Slave - multi-port device
AB_10GBT	12	RO	10GBASE-T Ability Not supported. Value always 0.
RES2	11:9	RO	Reserved Value always 0, writes ignored.
AB_5GBT	8	RO	5GBASE-T Ability Not supported by the GPHY. 0 _B UNABLE Do not advertise PHY as 5GBASE-T capable. 1 _B ABLE Advertises PHY as 5GBASE-T capable. Not supported.
AB_2G5BT	7	RW	2.5GBASE-T Ability 0 _B UNABLE Do not advertise PHY as 2.5GBASE-T capable. 1 _B ABLE Advertises PHY as 2.5GBASE-T capable.
FR_5GBT	6	RO	5GBASE-T Fast Retrain Ability Not supported by GPHY. 0 _B UNABLE Do not advertise PHY as 5GBASE-T fast retrain able. 1 _B ABLE Advertises PHY as 5GBASE-T fast retrain capable. Not supported.
FR_2G5BT	5	RW	2.5GBASE-T Fast Retrain Ability 0 _B UNABLE Do not advertise PHY as 2.5G fast retrain able. 1 _B ABLE Advertises PHY as 2.5G fast retrain able.
RES1	4:3	RO	Reserved Value always 0, writes ignored.

Field	Bits	Type	Description (cont'd)
LDPMA	2	RW	<p>GPHY PMA Training Reset Request</p> <p>When this bit is set to 1_B, the GPHY expects the link partner to reset the PMA training PRBS for every PMA training frame.</p> <p>When this bit is set to 0_B, the GPHY expects the link partner to run the PMA training PRBS continuously through every PMA training frame.</p>
FR	1	RW	Fast Retrain Ability
LDL	0	RW	GPHY Loop Timing Ability

MultiGBASE-T AN Status Register (Register 7.33)

IEEE Standard Register=7.33

ANEG_MGBT_AN_STA

MultiGBASE-T AN Status register (Register 7.33)

Reset Value

0000_H

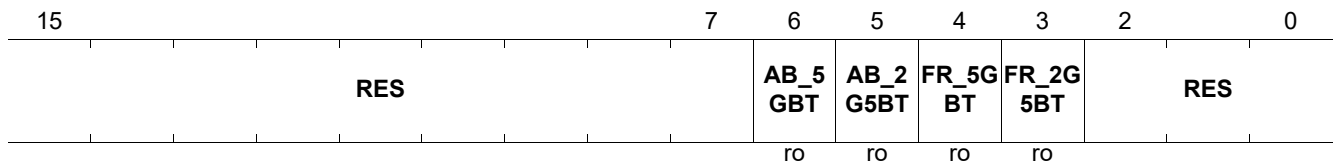

Field	Bits	Type	Description
AB_5GBT	6	RO	5GBASE-T Ability of Link Partner This bit is only valid when the link is established and ANEG completed. 0 _B UNABLE Link partner is not capable of 5GBASE-T. 1 _B ABLE Link partner is capable of 5GBASE-T.
AB_2G5BT	5	RO	2.5GBASE-T Ability of Link Partner This bit is only valid when the link is established and ANEG completed (bit 7.1.5 is set to 1 _B). 0 _B UNABLE Link partner is not capable of 2.5GBASE-T. 1 _B ABLE Link partner is capable of 2.5GBASE-T.
FR_5GBT	4	RO	5GBASE-T Fast Retrain Ability of Link Partner This bit is only valid when the link is established and ANEG completed. 0 _B UNABLE Link partner is not capable of 5GBASE-T fast retrain. 1 _B ABLE Link partner is capable of 5GBASE-T fast retrain
FR_2G5BT	3	RO	2.5GBASE-T Fast Retrain Ability of Link Partner This bit is only valid when the link is established and ANEG completed (bit 7.1.5 is set to 1 _B). 0 _B UNABLE Link partner is not capable of 2.5GBASE-T fast retrain. 1 _B ABLE Link partner is capable of 2.5GBASE-T fast retrain.

EEE Advertisement 1 (Register 7.60)

IEEE Standard Register=7.60

ANEG_EEE_AN_ADV1
Reset Value
EEE Advertisement 1 (Register 7.60)
0006_H

15																	7	6	5	4	3	2	1	0	
																		EEE_1 0G*	EEE_1 0G*	EEE_1 00*	EEE_1 0G*	EEE_1 00*	EEE_1 00*		RES
																		ro	ro	ro	ro	rw	rw		

Field	Bits	Type	Description
EEE_10GBKR	6	RO	Support of 10GBASE-KR EEE 0 _B DISABLED This PHY mode is not supported for EEE. 1 _B ENABLE This PHY mode is supported for EEE.
EEE_10GBKX 4	5	RO	Support of 10GBASE-KX4 EEE 0 _B DISABLED This PHY mode is not supported for EEE. 1 _B ENABLE This PHY mode is supported for EEE.
EEE_1000BKX	4	RO	Support of 1000BASE-KX EEE 0 _B DISABLED This PHY mode is not supported for EEE. 1 _B ENABLE This PHY mode is supported for EEE.
EEE_10GBT	3	RO	Support of 10GBASE-T EEE 0 _B DISABLED This PHY mode is not supported for EEE. 1 _B ENABLE This PHY mode is supported for EEE.
EEE_1000BT	2	RW	Support of 1000BASE-T EEE 0 _B DISABLED This PHY mode is not supported for EEE. 1 _B ENABLE This PHY mode is supported for EEE.
EEE_100BTX	1	RW	Support of 100BASE-TX EEE 0 _B DISABLED This PHY mode is not supported for EEE. 1 _B ENABLE This PHY mode is supported for EEE.

EEE Advertisement 2 (Register 7.62)

EEE advertisement 2 register is a continuation of EEE advertisement 1 register.

IEEE Standard Register=7.62

ANEG_EEE_AN_ADV2

Reset Value

EEE Advertisement 2 (Register 7.62)

0001_H

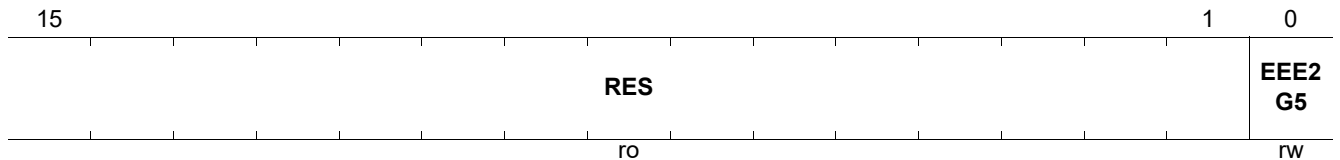

Field	Bits	Type	Description
RES	15:1	RO	Reserved
EEE2G5	0	RW	Advertise 2.5GBASE-T EEE Capability 0 _B DISABLED This PHY mode does not advertise 2.5GBASE-T EEE. 1 _B ENABLE This PHY mode advertises 2.5GBASE-T EEE.

EEE Link Partner Ability 2 (Register 7.63)

When the AN and training processes are complete, this register reflects the contents of the link partner's EEE advertisement 2 register.

IEEE Standard Register=7.63

All the bits in the EEE LP Ability 2 register are read-only. A write to the EEE LP Ability 2 register has no effect.

ANEG_EEE_LP_AB2

Reset Value

EEE Link Partner Ability 2 (Register 7.63)

0001_H

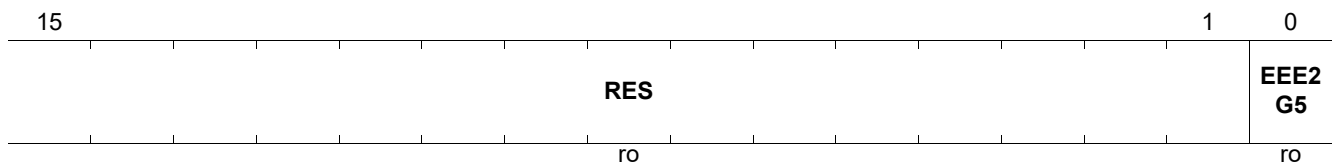

Field	Bits	Type	Description
RES	15:1	RO	Reserved
EEE2G5	0	RO	Link Partner Advertised 2.5GBASE-T EEE Capability 0 _B DISABLED LP is not 2.5GBASE-T EEE capable. 1 _B ENABLE LP is 2.5GBASE-T EEE capable.

MGBT ANEG Control 2 (Register 7.64)

This register is an extension of the ANEG Control Register for Multi GBT. It is used for 2.5 G ANEG configuration. IEEE Standard Register=7.64

Bit 7.64.3 is valid only when 7.32.5 is set to 1_B advertising fast retrain ability, and is used to request the link partner whether to initially reset the THP during fast retrain. THP Bypass Request is exchanged during link training, refer to 126.4.2.5.10.

When bit 7.64.3 is set to 0_B, the GPHY requests the link partner not to reset THP during fast retrain.

When bit 7.64.3 is set to 1_B, the GPHY requests the link partner to initially reset THP during fast retrain.

ANEG_MGBT_AN_CTRL2

Reset Value

MGBT ANEG Control 2 (Register 7.64)

0008_H

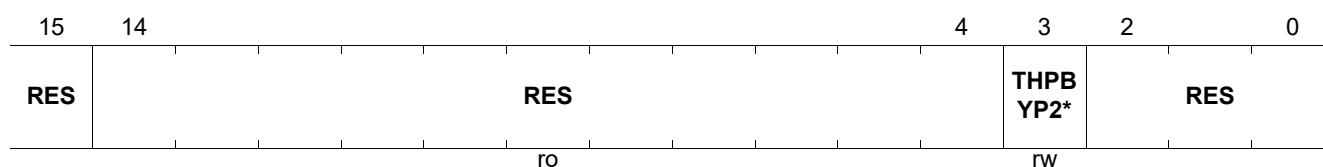

Field	Bits	Type	Description
RES	14:4	RO	Reserved
THPBYP2G5	3	RW	THP Bypass During Fast Retrain The GPHY requests a THP bypass during fast retrain. 0 _B NORST GPHY requests the link partner NOT to initially reset THP during fast retrain. 1 _B RST GPHY requests the link partner to initially reset THP during fast retrain.

6.4 Vendor Specific 1 Device Registers

This register file contains GPHY-specific registers for MMD=30 (decimal).

Table 35 Registers Overview- Vendor Specific 1 Device Registers

Register Short Name	Register Long Name	Reset Value
VSPEC1_LED0	Configuration for LED Pin 0 (Register 30.1)	0310 _H
VSPEC1_LED1	Configuration for LED Pin 1 (Register 30.2)	0320 _H
VSPEC1_LED2	Configuration for LED Pin 2 (Register 30.3)	0340 _H
VSPEC1_TXS_SCL_OFFSET	PHY Transmit Amplitude Control Register (Register 30.8)	0000 _H
VSPEC1_NBT_DS_CTRL	NBASE-T Downshift Control Register (Register 30.10)	0400 _H
VSPEC1_NBT_DS_STA	NBASE-T Downshift Status Register (Register 30.11)	0000 _H
VSPEC1_PM_CTRL	Packet Manager Control (Register 30.12)	3001 _H
VSPEC1_TEMP_STA	Temperature Code (Register 30.14)	0000 _H
VSPEC1_IMASK	VSPEC1 Interrupt Mask Register (Register 30.17)	0000 _H
VSPEC1_ISTAT	VSPEC1 Interrupt Mask Register (Register 30.18)	0000 _H
VSPEC1_USXGMII_STAT	USXGMII Status Register (Register 30.19)	0000 _H
VSPEC1_LANE_ASP_MAP	ASP Mapping to Physical Lanes (Register 30.20)	00E4 _H
VSPEC1_LOW_POWER_ENTRY_TIME	Time to Enter Low Power (Register 30.21)	0001 _H
VSPEC1_FRCTL	Fast Retrain Control and Status (Register 30.22)	0000 _H

6.4.1 VSPEC1 Register Descriptions

This section describes all the VSPEC1 registers in detail.

Configuration for LED Pin 0 (Register 30.1)

This register configures the behavior of the LED0 pin depending on predefined states or events the PHY entered into or raised. Since more than one event/state may be active at the same time, more than one function may apply at the same time. The priority from highest to lowest is given by the order: PULSE, BLINKS, BLINKF, and CON. The LED PULSE for the selected activity is only displayed for the link speed selected in CON. When CON is selected as NONE, no PULSE is displayed on the LED for any activity. To avoid the LED being constantly on when it is configured for pulsing alone, set the NO_CON bit in the PULSE field (bit 11).

IEEE Standard Register=30.1

VSPEC1_LED0

Reset Value

Configuration for LED Pin 0 (Register 30.1)

0310_H

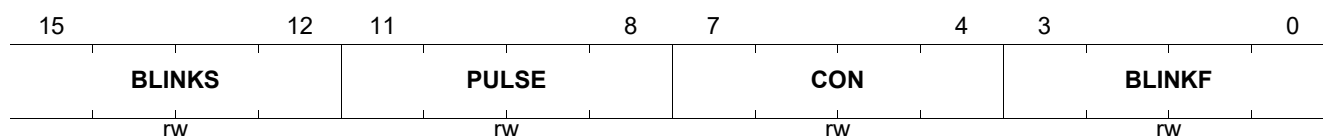

Field	Bits	Type	Description
BLINKS	15:12	RW	<p>Slow Blinking Configuration</p> <p>The BLINKS field selects the PHY states where the LED blinks with the predefined slow frequency. Each bit mask indicates a link speed. Combinations of these bit masks are used to provide a combination of link speed states to enable the behavior.</p> <p>0000_BNONE Not active 0001_BLINK10 Blink when link is 10 Mbps. 0010_BLINK100 Blink when link is 100 Mbps. 0100_BLINK1000 Blink when link is 1000 Mbps. 1000_BLINK2500 Blink when link is 2500 Mbps.</p>
PULSE	11:8	RW	<p>Pulsing Configuration</p> <p>The PULSE field is a mask field that combines certain events, such as TXACT RXACT, to generate a pulse on the LED when such an event is detected.</p> <p>0000_BNONE No pulsing 0001_BTXACT Transmit activity 0010_BRXACT Receive activity 0100_BCOL Collision 1000_BNO_CON Constant on behavior is switched off.</p>

Field	Bits	Type	Description (cont'd)
CON	7:4	RW	<p>Constant On Configuration</p> <p>The CON field selects the PHY states where the LED is constantly on. Each bit mask indicates a link speed. Combinations of these bit masks are used to provide a combination of link speed states to enable the behavior.</p> <p>0000_BNONE Not active 0001_BLINK10 On when link is 10 Mbps. 0010_BLINK100 On when link is 100 Mbps. 0100_BLINK1000 On when link is 1000 Mbps. 1000_BLINK2500 On when link is 2500 Mbps.</p>
BLINKF	3:0	RW	<p>Fast Blinking Configuration</p> <p>The BLINKF field selects the PHY states where the LED blinks with the predefined fast frequency. Each bit mask indicates a link speed. Combinations of these bit masks are used to provide a combination of link speed states to enable the behavior.</p> <p>0000_BNONE No active 0001_BLINK10 Blink when Link is 10 Mbps. 0010_BLINK100 Blink when Link is 100 Mbps. 0100_BLINK1000 Blink when Link is 1000 Mbps. 1000_BLINK2500 Blink when Link is 2500 Mbps.</p>

Configuration for LED Pin 1 (Register 30.2)

Configuration register for LED pin 1

IEEE Standard Register=30.2

VSPEC1_LED1

Reset Value

Configuration for LED Pin 1 (Register 30.2)

0320_H

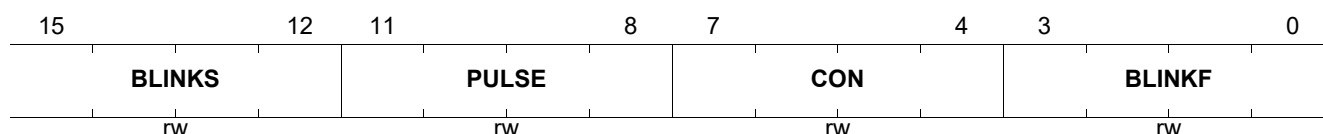

Field	Bits	Type	Description
BLINKS	15:12	RW	<p>Slow Blinking Configuration</p> <p>The BLINKS field selects the PHY states where the LED blinks with the predefined slow frequency. Each bit mask indicates a link speed. Combinations of these bit masks are used to provide a combination of link speed states to enable the behavior.</p> <p>0000_BNONE Not active 0001_BLINK10 Blink when link is 10 Mbps. 0010_BLINK100 Blink when link is 100 Mbps. 0100_BLINK1000 Blink when link is 1000 Mbps. 1000_BLINK2500 Blink when link is 2500 Mbps.</p>
PULSE	11:8	RW	<p>Pulsing Configuration</p> <p>The PULSE field is a mask field that combines certain events, such as TXACT RXACT, to generate a pulse on the LED when such an event is detected.</p> <p>0000_BNONE No pulsing 0001_BTXACT Transmit activity 0010_BRXACT Receive activity 0100_BCOL Collision 1000_BNO_CON Constant on behavior is switched off.</p>
CON	7:4	RW	<p>Constant On Configuration</p> <p>The CON field selects the PHY states where the LED is constantly on. Each bit mask indicates a link speed. Combinations of these bit masks are used to provide a combination of link speed states to enable the behavior.</p> <p>0000_BNONE Not active 0001_BLINK10 On when link is 10 Mbps. 0010_BLINK100 On when link is 100 Mbps. 0100_BLINK1000 On when link is 1000 Mbps. 1000_BLINK2500 On when link is 2500 Mbps.</p>

Field	Bits	Type	Description (cont'd)
BLINKF	3:0	RW	<p>Fast Blinking Configuration</p> <p>The BLINKF field selects the PHY states where the LED blinks with the predefined fast frequency. Each bit mask indicates a link speed. Combinations of these bit masks are used to provide a combination of link speed states to enable the behavior.</p> <p>0000_BNONE Not active 0001_BLINK10 Blink when link is 10 Mbps. 0010_BLINK100 Blink when link is 100 Mbps. 0100_BLINK1000 Blink when link is 1000 Mbps. 1000_BLINK2500 Blink when link is 2500 Mbps.</p>

Configuration for LED Pin 2 (Register 30.3)

Configuration register for LED pin 2

IEEE Standard Register=30.3

VSPEC1_LED2

Configuration for LED Pin 2 (Register 30.3)

Reset Value

0340_H

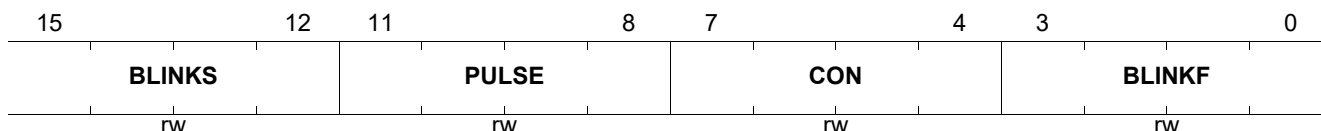

Field	Bits	Type	Description
BLINKS	15:12	RW	<p>Slow Blinking Configuration</p> <p>The BLINKS field selects the PHY states where the LED blinks with the predefined slow frequency. Each bit mask indicates a link speed. Combinations of these bit masks are used to provide a combination of link speed states to enable the behavior.</p> <p>0000_BNONE Not active 0001_BLINK10 Blink when link is 10 Mbps. 0010_BLINK100 Blink when link is 100 Mbps. 0100_BLINK1000 Blink when link is 1000 Mbps. 1000_BLINK2500 Blink when link is 2500 Mbps.</p>
PULSE	11:8	RW	<p>Pulsing Configuration</p> <p>The PULSE field is a mask field that combines certain events, such as TXACT RXACT, to generate a pulse on the LED when such an event is detected.</p> <p>0000_BNONE No pulsing 0001_BTXACT Transmit activity 0010_BRXACT Receive activity 0100_BCOL Collision 1000_BNO_CON Constant on behavior is switched off.</p>
CON	7:4	RW	<p>Constant On Configuration</p> <p>The CON field selects the PHY states where the LED is constantly on. Each bit mask indicates a link speed. Combinations of these bit masks are used to provide a combination of link speed states to enable the behavior.</p> <p>0000_BNONE Not active 0001_BLINK10 On when link is 10 Mbps. 0010_BLINK100 On when link is 100 Mbps. 0100_BLINK1000 On when link is 1000 Mbps. 1000_BLINK2500 On when link is 2500 Mbps.</p>

Field	Bits	Type	Description (cont'd)
BLINKF	3:0	RW	<p>Fast Blinking Configuration</p> <p>The BLINKF field selects the PHY states where the LED blinks with the predefined fast frequency. Each bit mask indicates a link speed. Combinations of these bit masks are used to provide a combination of link speed states to enable the behavior.</p> <p>0000_BNONE Not Active</p> <p>0001_BLINK10 Blink when link is 10 Mbps.</p> <p>0010_BLINK100 Blink when link is 100 Mbps.</p> <p>0100_BLINK1000 Blink when link is 1000 Mbps.</p> <p>1000_BLINK2500 Blink when link is 2500 Mbps.</p>

PHY Transmit Amplitude Control Register (Register 30.8)

This register adjusts the transmit amplitude of the PHY.

IEEE Standard Register=30.8

VSPEC1_TXS_SCL_OFFSET

Reset Value

PHY Transmit Amplitude Control Register (Register 30.8)

0000_H

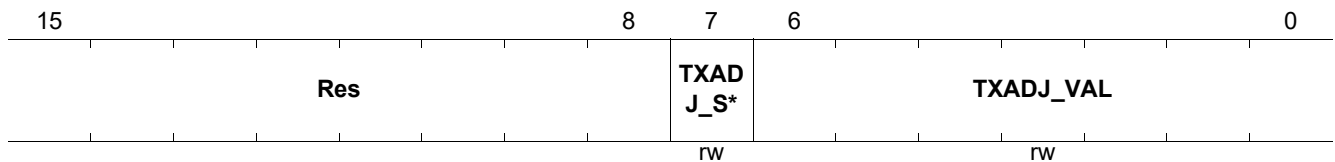

Field	Bits	Type	Description
TXADJ_SGN	7	RW	Transmit Amplitude Adjustment Sign 0 _B INC Increase transmit amplitude 1 _B DEC Decrease transmit amplitude
TXADJ_VAL	6:0	RW	Transmit Amplitude Adjustment Value Multiply the transmit amplitude by the following factor. (1 + (1-TXADJ_SGN*2)*TXADJ_VAL/128) The amplitude adjustment takes effect on the next link up.

NBASE-T Downshift Control Register (Register 30.10)

IEEE Standard Register=30.10

VSPEC1_NBT_DS_CTRL

Reset Value

NBASE-T Downshift Control Register (Register 30.10)

0400_H

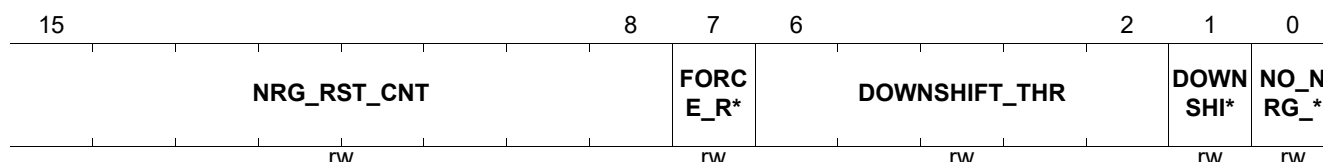

Field	Bits	Type	Description
NRG_RST_CNT	15:8	RW	Timer to Reset the Downshift Process When the energy is zero for a duration equal to NRG_RST_CNT seconds, the ANEG advertised capabilities are reset to the maximum GPHY capabilities. When NRG_RST_CNT is lower than 2, the ADS feature cannot be enabled. Default is 4 seconds. <i>Note: This timer only takes effect when NO_NRG_RST is set.</i>
FORCE_RST	7	RW	Force Reset of Downshift Process Setting this bit to 1 immediately resets the ANEG advertised capabilities to the maximum GPHY capabilities.
DOWNSHIFT_THR	6:2	RW	NBASE-T Downshift Training Counter Threshold dsh_thr variable in NBASE-T specification This is a 4-bit counter from 0 to 15 used to control the number of training cycles allowed for linkup, otherwise downshift.
DOWNSHIFT_EN	1	RW	NBASE-T Downshift Enable dsh_en variable in NBASE-T specification 0 _B DISABLE Disables NBT downshift. 1 _B ENABLE Enables NBT downshift.
NO_NRG_RST	0	RW	Advertise All Speeds if No Energy Detected When no energy is detected, this resets to advertise all speeds. Energy variable in NBASE-T specification 0 _B DISABLE Do not reset speeds advertised when no energy is detected. 1 _B ENABLE Reset speeds advertised when no energy is detected.

NBASE-T Downshift Status Register (Register 30.11)

IEEE Standard Register=30.11

VSPEC1_NBT_DS_STA

Reset Value

NBASE-T Downshift Status Register (Register 30.11)

0000_H

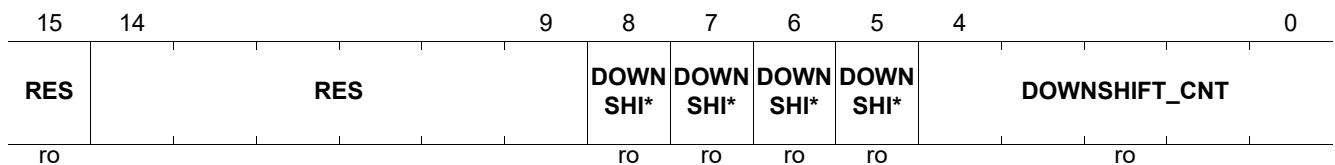

Field	Bits	Type	Description
DOWNSHIFT_1G	8	RO	Downshift from 1G to Lower Speed
DOWNSHIFT_2G5	7	RO	Downshift from 2.5 G to Lower Speed
DOWNSHIFT_5G	6	RO	Downshift 5G to Lower Speed Not supported by the GPHY
DOWNSHIFT_10G	5	RO	Downshift 10G to Lower Speed Not supported by the GPHY
DOWNSHIFT_CNT	4:0	RO	Training Attempt Counter Counts training attempts to select the operating speed. dsh_cnt state variable in NBASE-T specification

Packet Manager Control (Register 30.12)

IEEE Standard Register=30.12

Control the Packet Manager Configuration

VSPEC1_PM_CTRL

Reset Value

Packet Manager Control (Register 30.12)

3001_H

15	14	13	12	11	10	9	8	7	6	5	4	3	2	1	0
USXGMII*	USXGMII_REACH		MDINT_M*	RES	RES	RES	RES	RES		RES	PRE_EMP_EN	PCH_EN	SI	PM_EN	
rw	rw		rw	rw	rw	rw	rw	rw	rw	rw	rw	rw	rw	rw	rw

Field	Bits	Type	Description
USXGMII_FIX ED2G5	15	RW	Force USXGMII Interface to Remain in 2.5G Speed or TPI Link Speed Irrespective of the TPI link speed, the USXGMII operates at 2.5G speed when this bit is enabled. The GPHY packet manager performs the rate adaptation, and flow control is used to backpressure the MAC SoC when required. 0 _B NO_FORCE The USXGMII speed is reconfigured by the GPHY based on the TPI link speed. 1 _B FORCE The USXGMII speed is forced to the 2.5G speed.
USXGMII_REACH	14:12	RW	USXGMII Tx and Rx Configuration Based on the loop length between the GPHY and STA connected through USXGMII interface. No action taken if USXGMII interface is not available. 000 _B SHORT Short reach configuration of USXGMII Tx and Rx equalization by firmware 001 _B MEDIUM Medium reach configuration of USXGMII Tx and Rx equalization by firmware 010 _B LONG Long reach configuration of USXGMII Tx and Rx equalization by firmware 011 _B CUSTOM Custom Configuration At start-up default settings available after boot. If custom configuration of USXGMII Tx and Rx equalization required then the parameters can be set with custom values using GPHY API Others: Reserved.
MDINT_MODE	11	RW	MDIO Interrupt Mode Sets the mode of the MDIO interrupt signal. 0 _B TRI Tristate mode The MDIO interrupt signal is tristate when the interrupt is inactive. It is driven only when the interrupt is active. 1 _B PP Push-pull mode The MDIO interrupt signal is constantly driven.
PRE_EMP_EN	3	RW	Enable pre-emption support Not applicable if PM_EN=1 0 _B DISABLE Disable 1 _B ENABLE Enable

Field	Bits	Type	Description
PCH_EN	2	RW	<p>Enable PCH Enable PCH preamble</p> <p>0_B DISABLE Disable 1_B ENABLE Enable</p>
SI	1	RW	<p>Super Isolate Use in Super Isolate mode. Forces the device into a power down state by pin strapping (SLEEP) in which power consumption is the bare minimum required to still maintain the MII management interface communication. When activating the power down functionality, the PHY terminates active data links. The MII interface is also stopped in power down mode. See also IEEE 802.3-2008 22.2.4.1.5. The SI bit is only used to release the device from Super Isolate mode. Entering Super Isolate mode can only be activated by pin strapping at power up.</p> <p>0_B NORMAL Normal operational mode 1_B SUPER_ISOLATE Super Isolate mode</p>
PM_EN	0	RW	<p>Enable Packet Manager This field enables LPI generation within the GPHY. The Packet Manager on the GPHY supports the Smart AZ features. This bit is only applicable for port 0, once this bit in port 0 is set, it will apply to all GPHY ports. Resetting this bit back from 1 to 0 is not supported.</p> <p>0_B DISABLE PM is bypassed, transparent mode 1_B ENABLE SmartAZ mode</p>

Temperature Code (Register 30.14)

Junction temperature is presented in degrees Celsius
IEEE Standard Register=30.14

VSPEC1_TEMP_STA

Reset Value

Temperature Code (Register 30.14)

0000_H

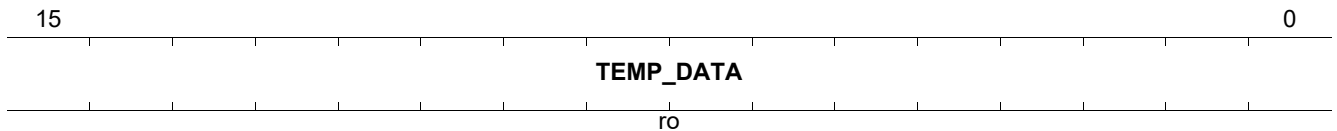

Field	Bits	Type	Description
TEMP_DATA	15:0	RO	<p>Junction Temperature</p> <p>The temperature is represented as a two's complement binary fixed point number, of which the 7 LSBs are fractional. The STA must take the thermal mitigation measures when the junction temperature exceeds the normal operating range if ADS is disabled.</p> <p>TEMP_DATA is invalid when the value is 0000_H.</p> <p>Example T_j Values (Decimal):</p> <ul style="list-style-type: none"> • For T_j = -40 degC, TEMP_DATA = EC00_H • For T_j = +125 degC, TEMP_DATA = 3E80_H

VSPEC1 Interrupt Mask Register (Register 30.17)

This register defines the mask for the Interrupt Status Register (ISTAT), which contains the event source for the MDINT interrupt sent from the GPHY to an external chip. The mask is cleared whenever the corresponding interrupt is serviced.

The information about the interrupt source is indicated in the VSPEC1_ISTAT register.

IEEE Standard Register=30.17

VSPEC1_IMASK

Reset Value

VSPEC1 Interrupt Mask Register (Register 30.17)

0000_H

15																	6	5	4	3	2	1	0	
																			CDET	RES	RES	RES	RES	RES
																			rw	rw	rw	rw	rw	rw

Field	Bits	Type	Description
CDET	5	RW	Cable Detect Interrupt When active, MDINT is activated upon interrupt from detection of energy on the link. 0 _B INACTIVE Interrupt is masked out. 1 _B ACTIVE Interrupt is activated.

VSPEC1 Interrupt Status Register (Register 30.18)

This register defines the event source for the MDINT interrupt sent from the GPHY to an external chip based on the mask settings in the VSPEC1_IMASK register.

VSPEC1_ISTAT is a cleared on read by the STA.

IEEE Standard Register=30.18

VSPEC1_ISTAT **Reset Value**
0000_H
VSPEC1 Interrupt Status Register (Register 30.18)

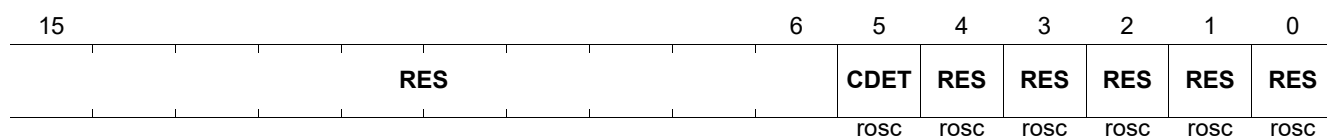

Field	Bits	Type	Description
CDET	5	ROSC	Cable Detect Interrupt When this bit is set, MDINT is activated upon interrupt from detection of energy on the link. 0 _B INACTIVE This event is not the interrupt source. 1 _B ACTIVE The cable detect interrupt is the source of the interrupt.

USXGMII Status Register (Register 30.19)

This is the USXGMII status register.

All the bits in this status register are read only. A write has no effect.

IEEE Standard Register=30.19

VSPEC1_USXGMII_STAT

Reset Value

USXGMII Status Register (Register 30.19)

0000_H

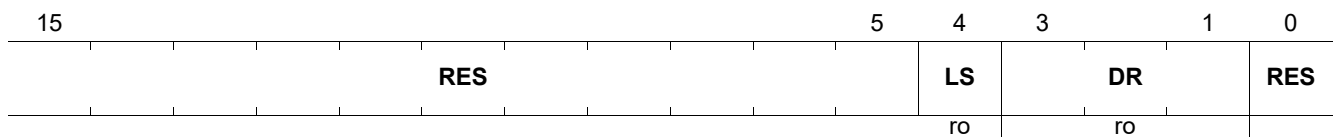

Field	Bits	Type	Description
LS	4	RO	USXGMII Link Status Indicates the link status of the USXGMII. 0 _B INACTIVE The link is down. No communication with link partner is possible. 1 _B ACTIVE The link is up. Data communication with link partner is possible.
DR	3:1	RO	USXGMII Data Rate This field indicates the operating data rate of USXGMII when the link is up. 000 _B DR_10 USXGMII link rate is 10 Mbps. 001 _B DR_100 USXGMII link rate is 100 Mbps. 010 _B DR_1G USXGMII link rate is 1000 Mbps. 011 _B DR_ANEG USXGMII is in auto-negotiation. 100 _B DR_2G5 USXGMII link rate is 2500 Mbps.

ASP Mapping to Physical Lanes (Register 30.20)

This register offers a programmable option to map physical lanes A, B, C, and D of the TPI to the ASPs. Each ASP must be mapped to each lane.

IEEE Standard Register=30.20

VSPEC1_LANE_ASP_MAP

Reset Value

ASP Mapping to Physical Lanes (Register 30.20)

00E4_H

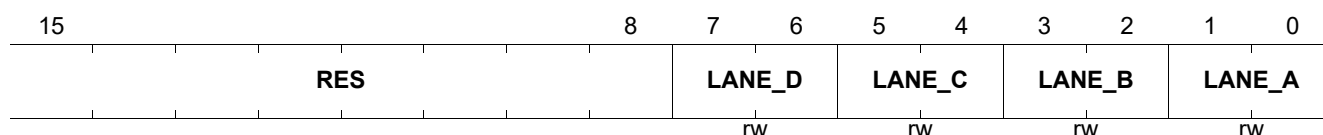

Field	Bits	Type	Description
LANE_D	7:6	RW	Map Physical Lane-D to the ASP 00 _B ASPA Map Physical Lane-D to the ASP-A 01 _B ASPB Map Physical Lane-D to the ASP-B 10 _B ASPC Map Physical Lane-D to the ASP-C 11 _B ASPD Map Physical Lane-D to the ASP-D
LANE_C	5:4	RW	Map Physical Lane-C to the ASP 00 _B ASPA Map Physical Lane-C to the ASP-A 01 _B ASPB Map Physical Lane-C to the ASP-B 10 _B ASPC Map Physical Lane-C to the ASP-C 11 _B ASPD Map Physical Lane-C to the ASP-D
LANE_B	3:2	RW	Map Physical Lane-B to the ASP 00 _B ASPA Map Physical Lane-B to the ASP-A 01 _B ASPB Map Physical Lane-B to the ASP-B 10 _B ASPC Map Physical Lane-B to the ASP-C 11 _B ASPD Map Physical Lane-B to the ASP-D
LANE_A	1:0	RW	Map Physical Lane-A to the ASP 00 _B ASPA Map Physical Lane-A to the ASP-A 01 _B ASPB Map Physical Lane-A to the ASP-B 10 _B ASPC Map Physical Lane-A to the ASP-C 11 _B ASPD Map Physical Lane-A to the ASP-D

Time to Enter Low Power (Register 30.21)

Programmable option to delay the time taken to enter low power mode.

IEEE Standard Register=30.21

VSPEC1_LOW_POWER_ENTRY_TIME

Reset Value

Time to Enter Low Power (Register 30.21)

0001_H

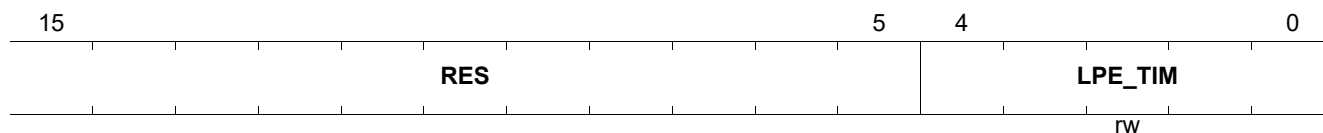

Field	Bits	Type	Description
LPE_TIM	4:0	RW	Low Power Entry Time This is the time taken from detection of no activity on the line to the low power completion. The granularity is 4 seconds and adds 2.4 seconds to 5.6 seconds on to the initial time.

Fast Retrain Control and Status (Register 30.22)

This register supports fast retrain (FR) as follows:

1. Configures the FR capability (IEEE, CISCO(THPBYP, TXDIS, EXT) [8]).
2. Records the link partner FR capability.
3. Reports the FW resolution of the FR capability.
4. Defines the maximum allowed number of times to try FR before performing a full link down.

IEEE Standard Register=30.22

VSPEC1_FRCTL

Reset Value

Fast Retrain Control and Status (Register 30.22)

0000_H

15	14	13	12	11	10	9	8	7	6	5	4	3	2	1	0
MAX_FR_*	STAT_IE*	STAT_CI*	STAT_TH*	STAT_TX*	STAT_EXT	LP_IEEE	LP_CISCO	LP_THPB*	LP_TXDIS	LP_EXT	CAP_III	CAP_CIS*	CAP_THP*	CAP_TXD*	CAP_EXT
RW	RO	RO	RO	RO	RO	RO	RO	RO	RO	RO	RW	RW	RW	RW	RW

Field	Bits	Type	Description
MAX_FR_RETRY	15	RW	Maximum Number of FR Retries Before Taking Linking Down 0 _B DISABLE Maximum number of retries limited to 4. 1 _B ENABLE Maximum number of retries limited to 8.
STAT_IEEE	14	RO	Resolved for IEEE FR 0 _B DISABLE Resolved to no IEEE FR. 1 _B ENABLE Resolved to IEEE FR.
STAT_CISCO	13	RO	Resolved for CISCO FR 0 _B DISABLE Resolved to no CISCO FR 1 _B ENABLE Resolved to CISCO FR
STAT_THPBYP	12	RO	Resolved Status THP BYP during COEF_EXCH for Either CISCO FR or IEEE FR 0 _B DISABLE Resolved that THP is not BYP for either CISCO FR or IEEE FR 1 _B ENABLE Resolved that THP is BYP during COEF EXCH for either CISCO FR or IEEE FR
STAT_TXDIS	11	RO	Resolved Status for CISCO FR with TX DISABLE 0 _B DISABLE Resolved that CISCO FR is not followed by TX DISABLE after link fail signaling 1 _B ENABLE Resolved that CISCO FR is followed by TX DISABLE after link fail signaling
STAT_EXT	10	RO	Resolved Status for CISCO Extended FR Timing 0 _B DISABLE Resolved for no CISCO FR with extended timing 1 _B ENABLE Resolved for CISCO FR with extended timing
LP_IEEE	9	RO	LP Request for IEEE FR 0 _B DISABLE No advertise for IEEE FR 1 _B ENABLE Advertise capable of doing IEEE FR

Field	Bits	Type	Description (cont'd)
LP_CISCO	8	RO	LP Request for CISCO FR 0 _B DISABLE No advertise for CISCO FR 1 _B ENABLE Advertise capable of doing CISCO FR
LP_THPBYP	7	RO	LP Request for THP BYP During COEF_EXCH for Either CISCO FR or IEEE FR 0 _B DISABLE No request for THP BYP for either CISCO FR or IEEE FR 1 _B ENABLE Request for THP BYP during COEF EXCH for either CISCO FR or IEEE FR
LP_TXDIS	6	RO	LP Request for CISCO FR with TX DISABLE 0 _B DISABLE No request that CISCO FR is followed by TX DISABLE after link fail signaling 1 _B ENABLE Request that CISCO FR is followed by TX DISABLE after link fail signaling
LP_EXT	5	RO	LP Request for CISCO Extended FR Timing 0 _B DISABLE No request for CISCO FR with extended timing 1 _B ENABLE Request for CISCO FR with extended timing
CAP_IEEE	4	RW	Request for IEEE FR 0 _B DISABLE No advertise for IEEE FR 1 _B ENABLE Advertise capable of doing IEEE FR
CAP_CISCO	3	RW	Capable of Advertising CISCO FR 0 _B DISABLE No advertise for CISCO FR 1 _B ENABLE Advertise capable of doing CISCO FR
CAP_THPBYP	2	RW	Request LP for THP BYP during COEF_EXCH for Both CISCO FR and IEEE FR 0 _B DISABLE No request to LP for THP BYP for either CISCO FR or IEEE FR 1 _B ENABLE Request LP for THP BYP during COEF EXCH for either CISCO FR or IEEE FR
CAP_TXDIS	1	RW	Request for CISCO FR with TX DISABLE 0 _B DISABLE No request for CISCO FR with TX DISABLE after link fail signaling 1 _B ENABLE Advertise request that CISCO FR is followed by TX DISABLE after link fail signaling
CAP_EXT	0	RW	Request for CISCO Extended FR Timing 0 _B DISABLE No request for CISCO FR with extended timing 1 _B ENABLE Advertise request for CISCO FR with extended timing

6.5 Vendor Specific 2 Device Registers

This register file contains the GPHY-specific registers for MMD=31 (decimal).

Table 36 Registers Overview- Vendor Specific 2 Device Registers

Register Short Name	Register Long Name	Reset Value
VPSPEC2_WOL_CTL	WoL Control Register (Register 31.3590)	0000 _H
VPSPEC2_WOL_AD01	WoL Address Byte 0 and 1 (Register 31.3592)	0000 _H
VPSPEC2_WOL_AD23	WoL Address Byte 2 and 3 (Register 31.3593)	0000 _H
VPSPEC2_WOL_AD45	WoL Address Byte 4 and 5 (Register 31.3594)	0000 _H
VPSPEC2_WOL_PW01	WoL SecureON Password Byte 0 (Register 31.3595)	0000 _H
VPSPEC2_WOL_PW23	WoL SecureON Password Byte 2 and 3 (Register 31.3596)	0000 _H
VPSPEC2_WOL_PW45	WoL SecureON Password Byte 4 and 5 (Register 31.3597)	0000 _H

6.5.1 VSPEC2 Register Descriptions

This section describes all the VSPEC2 registers in detail.

Wake-on-LAN Control Register (Register 31.3590)

This is the Wake-on-LAN control register. Redirected to PCS_PDI_WOL_CTL.

IEEE Standard Register=31.3590

VPSPEC2_WOL_CTL

Wake-on-LAN Control Register (Register 31.3590)

Reset Value

0000_H

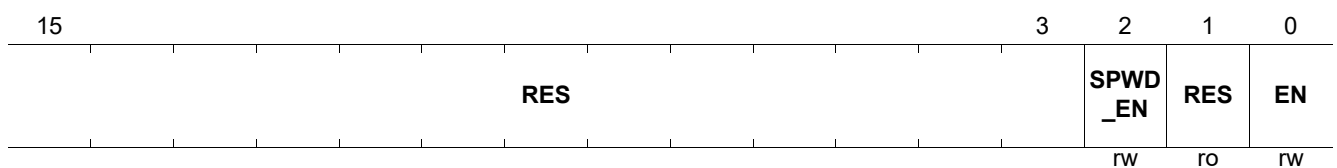

Field	Bits	Type	Description
SPWD_EN	2	RW	Secure-ON Password Enable When this bit is set to enabled, the SecureON password is checked after 16 MAC address repetitions. 0 _B DISABLED Disables the SecureON password check 1 _B ENABLED Enables the SecureON password check
RES	1	RO	Reserved Must always be written to 0.
EN	0	RW	Enables the Wake-on-LAN Functionality When WoL is enabled, the PHY scans for the configured magic packet and indicates its reception via the register bit ISTAT. WoL and optionally also via interrupt. 0 _B DISABLED Disables the WoL functionality 1 _B ENABLED Enables the WoL functionality

Wake-on-LAN Address Byte 0 and 1 (Register 31.3592)

Wake-on-LAN Address Byte 0 and 1. Redirected to PCS_PDI_WOL_AD01.

IEEE Standard Register=31.3592

VPSPEC2_WOL_AD01

Reset Value

Wake-on-LAN Address Byte 0 and 1 (Register 31.3592)

0000_H

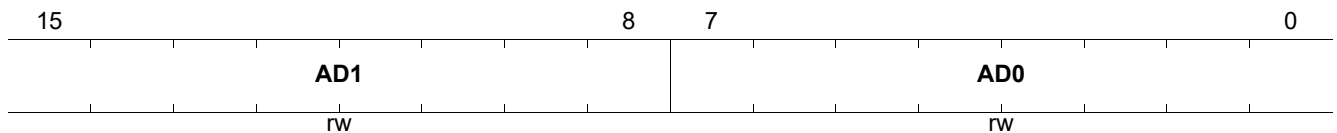

Field	Bits	Type	Description
AD1	15:8	RW	Address Byte 1 Defines byte 1 of the WoL-designated MAC address to which the PHY is sensitive.
AD0	7:0	RW	Address Byte 0 Defines byte 0 of the WoL-designated MAC address to which the PHY is sensitive.

Wake-on-LAN Address Byte 2 and 3 (Register 31.3593)

Wake-on-LAN Address Byte 2 and 3. Redirected to PCS_PDI_WOL_AD23.

IEEE Standard Register=31.3593

VPSPEC2_WOL_AD23

Reset Value

Wake-on-LAN Address Byte 2 and 3 (Register 31.3593)

0000_H

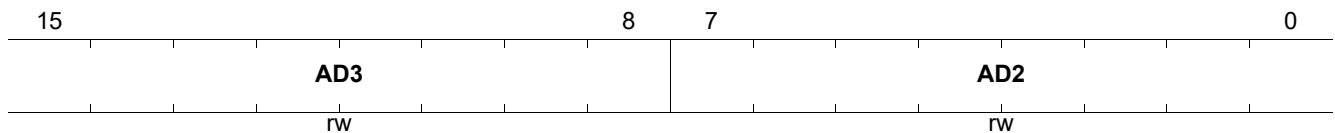

Field	Bits	Type	Description
AD3	15:8	RW	Address Byte 3 Defines byte 3 of the WoL-designated MAC address to which the PHY is sensitive.
AD2	7:0	RW	Address Byte 2 Defines byte 2 of the WoL-designated MAC address to which the PHY is sensitive.

Wake-on-LAN Address Byte 4 and 5 (Register 31.3594)

Wake-on-LAN Address Byte 4 and 5. Redirected to PCS_PDI_WOL_AD45.
IEEE Standard Register=31.3594

VPSPEC2_WOL_AD45

Reset Value

Wake-on-LAN Address Byte 4 and 5 (Register 31.3594)

0000_H

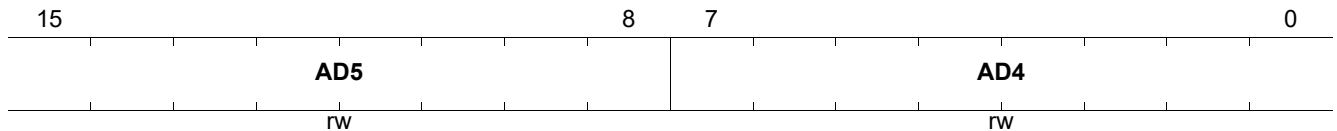

Field	Bits	Type	Description
AD5	15:8	RW	Address Byte 5 Defines byte 5 of the WoL-designated MAC address to which the PHY is sensitive.
AD4	7:0	RW	Address Byte 4 Defines byte 4 of the WoL-designated MAC address to which the PHY is sensitive.

Wake-on-LAN SecureON Password Byte 0 (Register 31.3595)

Wake-on-LAN SecureON Password Byte 0. Redirected to PCS_PDI_WOL_PWD01.

IEEE Standard Register=31.3595

VPSPEC2_WOL_PW01

Reset Value

Wake-on-LAN SecureON Password Byte 0 (Register 31.3595)

0000_H

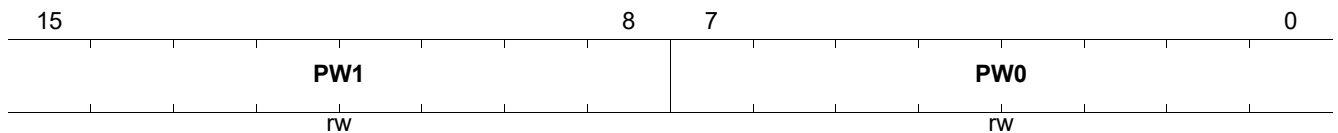

Field	Bits	Type	Description
PW1	15:8	RW	SecureON Password Byte 1 Defines byte 1 of the WoL-designated SecureON password to which the PHY is sensitive.
PW0	7:0	RW	SecureON Password Byte 0 Defines byte 0 of the WoL-designated SecureON password to which the PHY is sensitive.

Wake-on-LAN SecureON Password Byte 2 and 3 (Register 31.3596)

Wake-on-LAN SecureON Password Byte 2 and 3. Redirected to PCS_PDI_WOL_PWD23.

IEEE Standard Register=31.3596

VPSPEC2_WOL_PW23

Reset Value

Wake-on-LAN SecureON Password Byte 2 and 3 (Register 31.3596)

0000_H

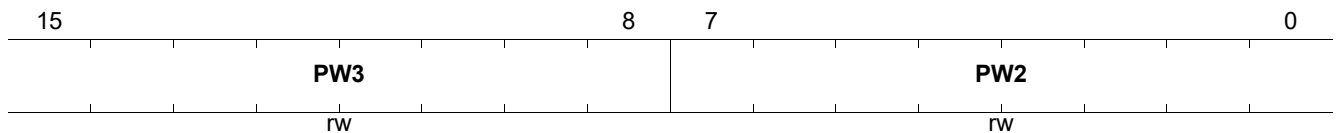

Field	Bits	Type	Description
PW3	15:8	RW	SecureON Password Byte 3 Defines byte 3 of the WoL-designated SecureON password to which the PHY is sensitive.
PW2	7:0	RW	SecureON Password Byte 2 Defines byte 2 of the WoL-designated SecureON password to which the PHY is sensitive.

Wake-on-LAN SecureON Password Byte 4 and 5 (Register 31.3597)

Wake-on-LAN SecureON Password Byte 4 and 5. Redirected to PCS_PDI_WOL_PWD45.

IEEE Standard Register=31.3597

VPSPEC2_WOL_PW45

Reset Value

Wake-on-LAN SecureON Password Byte 4 and 5 (Register 31.3597)

0000_H

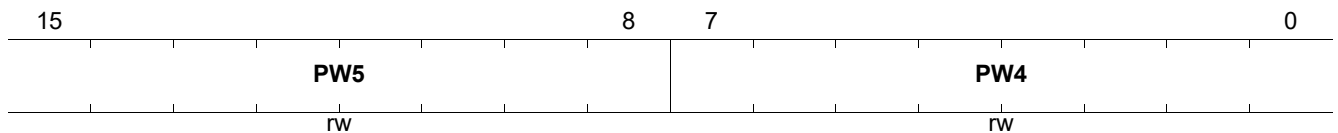

Field	Bits	Type	Description
PW5	15:8	RW	SecureON Password Byte 5 Defines byte 5 of the WoL-designated SecureON password to which the PHY is sensitive.
PW4	7:0	RW	SecureON Password Byte 4 Defines byte 4 of the WoL-designated SecureON password to which the PHY is sensitive.

7 Electrical Characteristics

This chapter provides the electrical characteristics for the MxL86288L.

7.1 Absolute Maximum Ratings

Table 37 shows the absolute maximum ratings for the MxL86288L.

Table 37 Absolute Maximum Ratings

Parameter	Symbol	Values			Unit	Note / Test Condition
		Min.	Typ.	Max.		
Storage Temperature Limits	T_{STG}	-55.0	–	125.0	°C	–
Soldering Temperature	T_{SOL}	–	–	260.0	°C	Compliance with lead free re-flow soldering profile as J-STD-020D
Moisture Level 3 Temperature Limits	T_{ML3}	–	–	260.0	°C	According to IPS J-STD 020
Absolute Junction Temperature	T_{JABS}	-40.0		125	°C	The thermal solution must ensure that T_J never exceeds T_{JABS} maximum. The chip resets the device when $T_J > T_{JABS}$ maximum to prevent any damage to occur.
DC Voltage Limits on VDD3V3PAD0, VDD3V3PAD1 Pins	V_{DDP3V3}	-0.5	–	+3.63	V	Generic ball V_{HIGH} supply
DC Voltage Limits on VDDP_PAD Pins when Ball K4 Pin Strap PS_MDIO_VOLTAGE is HIGH	V_{DDP}	-0.5	–	+3.63	V	Multi voltage ball V_{HIGH} supply
DC Voltage Limits on VDDP_PAD Pins when Ball K4 Pin Strap PS_MDIO_VOLTAGE is LOW	V_{DDP}	-0.5	–	+1.98	V	Multi voltage ball supply. 1.8 V supply dedicated to MDIO pins in lower mode
DC Voltage Limits on VDDA3V3_0, VDDA3V3_1, VDDA3V3_2, VDDA3V3_3, VDDA3V3_4, VDDA3V3_5, VDDA3V3_6, and VDDA3V3_7 Pins	V_{DDA3V3}	-0.5	–	+3.63	V	Chip analog V_{HIGH} supply
DC Voltage Limits on VDDA1V8_0, VDDA1V8_1 Pins	V_{DDA1V8}	-0.5	–	+1.98	V	Chip analog supply

Electrical Characteristics
Table 37 Absolute Maximum Ratings (cont'd)

Parameter	Symbol	Values			Unit	Note / Test Condition
		Min.	Typ.	Max.		
DC Voltage Limits on VDDA1V8PORXO, VDDA1V8_PVT, VCC1V8_OTP Pins	$V_{\text{DDA1V8PORXO}}$ $V_{\text{DDA1V8PVT}}$ V_{CC1V8OTP}	-0.5	–	+1.98	V	Chip clocking supply
DC Voltage Limits on VPHA1V8_0, VPHA1V8_1, and VDDA1V8_PLL Pins	V_{PH} $V_{\text{DDA1V8PLL}}$	-0.5	–	+1.98	V	USXGMII, LJ PLL V_{HIGH} supply
DC Voltage Limits on VDDA1V2CDB0, VDDA1V2CDB1 Pins	$V_{\text{DDA1V2CDB}}$	-0.5	–	+1.32	V	Chip analog supply
DC Voltage Limits on VDDA0V8_0, VDDA0V8_1, VDDD0V8REF, VDDD0V8POST Pins	V_{DDA0V8} $V_{\text{DDD0V8PLL}}$	-0.5	–	+0.88	V	Chip analog V_{LOW} supply, LJ PLL V_{LOW} supply
DC Voltage Limits on VDDD0V8_COR Pins	V_{DD}	-0.5	–	+0.88	V	Chip core supply
DC Voltage Limits on VA0V8_0, VA0V8_1 Pins	V_{P}	-0.5	–	+0.88	V	USXGMII V_{LOW} supply
DC Voltage Limits on Any Other Pins ¹⁾ with Respect to Ground	V_{DC}	-0.5	–	$V_{\text{DDP3V3}} + 0.5$	V	Unless specified otherwise
XTAL1 Input Voltage	V_{XTAL1}	-0.30	–	2.0	V	–
ESD HBM Robustness	$V_{\text{ESD,HBM}}$	–	–	1000.0	V	According to ANSI/ESDA/JEDEC JS-001-2014
ESD CDM Robustness	$V_{\text{ESD,CDM}}$	–	–	250.0	V	According to ANSI/ESDA/JEDEC JS-002-2014

1) Any pin that is not a supply pin out of one of the domains: V_{DDP} , V_{PH} , V_{P} , V_{DDA3V3} , $V_{\text{DDA1V8PORXO}}$, $V_{\text{DDA1V2CDB}}$, V_{DDA0V8} , V_{DD} , and V_{DDA1V8} .

Attention: Stresses above the maximum values listed in this table may cause permanent damage to the device. Exposure to absolute maximum rating conditions for extended periods may affect device reliability. Maximum ratings are absolute ratings; exceeding only one of these values may cause irreversible damage to the device.

7.2 Operating Range

Table 38 defines the limit values of voltages and temperature which may be applied to guarantee proper operation of the MxL86288L.

Table 38 Operating Range

Parameter	Symbol	Values			Unit	Note / Test Condition
		Min.	Typ.	Max.		
Ambient Temperature under Bias	T_A	0	–	70	°C	The thermal design must ensure that the maximum junction temperature is not exceeded. The use of a heat sink may be suitable.
Junction Temperature	T_j	–	–	110.0	°C	Thermal solution must ensure that T_j remains within operating range and never exceeds maximum absolute ratings (T_{JABS}).
Generic Pin Supply Voltage	V_{DDP3V3}	3.14	3.30	3.46	V	Generic pin V_{HIGH} supply
Multi Voltage Pin Supply Voltage for MDIO Signals when Ball K4 Pin Strap PS_MDIO_VOLTAGE is HIGH	V_{DDP}	3.14	3.30	3.46	V	Multi voltage pin V_{HIGH} supply
Multi Voltage Pin Supply Voltage for MDIO Signals when Ball K4 Pin Strap PS_MDIO_VOLTAGE is LOW	V_{DDP}	1.71	1.80	1.89	V	Multi voltage pin supply. 1.8 V supply dedicated to MDIO pins in lower mode
Analog High Supply Voltage	V_{DDA3V3}	3.14	3.30	3.46	V	Chip analog V_{HIGH} supply
XO Supply Voltage	$V_{DDA1V8POR}$ XO	1.71	1.80	1.89	V	Chip clocking V_{HIGH} supply
Analog Medium Supply Voltage	V_{DDA1V8}	1.71	1.80	1.89	V	Chip analog V_{MED} supply
CDB Supply Voltage	$V_{DDA1V2CDB}$	1.14	1.20	1.26	V	Chip analog supply
USXGMII High Supply Voltage	V_{PH}	1.71	1.80	1.89	V	USXGMII V_{HIGH} supply
LJ PLL High Supply Voltage	$V_{DDA1V8PLL}$	1.71	1.80	1.89	V	LJ PLL V_{HIGH} supply
Analog Low Supply Voltage	V_{DDA0V8}	0.76	0.8	0.84	V	Chip analog V_{LOW} supply
LJ PLL Low Supply Voltage	$V_{DDD0V8PLL}$	0.76	0.8	0.84	V	LJ PLL V_{LOW} supply
Chip Core Supply Voltage	V_{DD}	0.76	0.8	0.84	V	Chip core supply
USXGMII Low Supply Voltage	V_P	0.76	0.8	0.84	V	USXGMII V_{LOW} supply
Ground	V_{SS}	0.00	0.00	0.00	V	–

Attention: Operations above the maximum values listed here for extended periods may adversely affect long-term reliability of the device.

7.3 Typical Power Consumption

Table 39 lists the typical power consumption for different modes. Typical power is the power consumed by a nominal process device, nominal supply voltages, at 25°C ambient temperature and a CAT5e link segment.

The conditions for Link-up are full speed and bidirectional, full duplex traffic on all 8 ports. There are 10G links on both SerDes interfaces.

Table 39 Typical Power Consumption

	3.3 V V _{HIGH} Domain Current	1.8 V Domain Current	1.2 V Domain Current	0.8 V V _{LOW} Domain Current	0.8 V V _P Domain Current	Chip Power
Unit	mA	mA	mA	mA	mA	W
2500BASE-T Link-up, 100 m Cable	393	138	470	3453	128	5.0
2500BASE-T Link-up, 30 m Cable	372	136	450	2930	127	4.5
2500BASE-T EEE	313	124	138	1592	124	2.8
1000BASE-T Link-up, 100 m Cable	306	136	435	1489	124	3.1
1000BASE-T EEE	47	126	123	895	126	1.3
100BASE-TX Link-up, 100 m Cable	91	124	111	694	122	1.3
100BASE-TX EEE	60	148	120	646	124	1.0
10BASE-Te Link-up, 100 m Cable	89	127	66	616	117	1.2
Cable Unplugged - ANEG	40	127	66	635	123	1.0
Cable Unplugged - Low Power	23	121	4	338	123	0.7
Reset	3	25	0	64	3	0.1

7.4 Maximum Thermal Design Power

Table 40 lists the maximum Thermal Design Power (TDP). The TDP is the power consumption for a full traffic load and worst-case process, supply voltage, cable, and temperature conditions. This value is relevant to design the thermal solution.

Table 40 Maximum Power Consumption

Condition	Maximum Power (W)
Maximum Chip Power at Maximum Operating Range	7.0

Note: With a properly designed thermal solution (heat sink), it is unlikely that T_j exceeds the maximum operating junction temperature. An excess is reported in the MDIO register VSPEC1_TEMP_STA and the STA can initiate a renegotiation to a lower link rate to get T_j back into the operating temperature range if ADS is disabled.

7.5 Maximum Current

Table 41 provides the maximum current to dimension the power supply. It is the maximum current consumption per rail for a full traffic load and worst-case process, supply voltage and temperature conditions that may occur in any operating state of the device. The maximum current can be higher than the steady state current, for instance in training phases of the internal filters.

Electrical Characteristics

Table 41 Maximum Current Per Rail

3.3 V Domain Current	1.8 V Domain Current	1.2 V Domain Current	0.8 V V _{LOW} Domain Current	0.8 V V _P Domain Current
mA	mA	mA	mA	mA
477	154	587	6000	203

7.6 DC Characteristics

These sections document the DC characteristics of the MxL86288L external interfaces.

7.6.1 Digital Interfaces

This section defines the DC characteristics of the GPIO interface as follows:

- General Purpose IO
- MDIO
- QSPI
- UART
- I²C
- Interrupts
- Clock Input and Outputs
- LED
- JTAG
- HRSTN

Table 42 summarizes the DC characteristics for $V_{DDP} = 3.3\text{ V}$.

Table 42 DC Characteristics of the GPIO Interfaces (VDDP = 3.3 V)

Parameter	Symbol	Values			Unit	Note / Test Condition
		Min.	Typ.	Max.		
Input High Voltage	V_{IH}	$0.7 \cdot V_{DDP}$	–	$V_{DDP} + 0.3$	V	–
Input Low Voltage	V_{IL}	–0.3	–	$0.3 \cdot V_{DDP}$	V	–
Output High Voltage	V_{OH}	$V_{DDP} - 0.4$	–	–	V	$I_{OH} = 2, 4, 8, 12\text{ mA}$
Output Low Voltage	V_{OL}	–	–	0.4	V	$I_{OL} = 2, 4, 8, 12\text{ mA}$

Table 43 summarizes the DC characteristics for $V_{DDP} = 1.8\text{ V}$.

Table 43 DC Characteristics of the GPIO Interfaces (VDDP = 1.8 V¹⁾)

Parameter	Symbol	Values			Unit	Note / Test Condition
		Min.	Typ.	Max.		
Input High Voltage	V_{IH}	$0.65 \cdot V_{DDP}$	–	$V_{DDP} + 0.3$	V	–
Input Low Voltage	V_{IL}	–0.3	–	$0.35 \cdot V_{DDP}$	V	–
Output High Voltage	V_{OH}	$V_{DDP} - 0.4$	–	–	V	$I_{OH} = 2, 4, 8, 12\text{ mA}$
Output Low Voltage	V_{OL}	–	–	0.4	V	$I_{OL} = 2, 4, 8, 12\text{ mA}$

1) 1.8V is only applicable to the pins specified in **PS_MDIO_VOLTAGE** of **Table 18**.

7.6.2 Twisted Pair Interface

The TPI conforms to the specifications of 10BASE-Te (Clause 14), 100BASE-TX (Clause 25), 1000BASE-T (Clause 40), and 2.5GBASE-T (Clause 126) given in IEEE802.3, and ANSI X3.263-1995.

7.6.3 Built-in Temperature Sensor

Table 44 provides the parameters of the integrated temperature sensor.

Table 44 Temperature Sensor Characteristics

Parameter	Symbol	Values			Unit	Note / Test Condition
		Min.	Typ.	Max.		
Temperature Range	T _{range}	-40		125	°C	The thermal mitigation measures must ensure that T _j remains within the operating range. When T _j exceeds the maximum ratings, the device performs a self-reset to prevent damage.
Resolution		–	12	–	bits	–
Accuracy		-3	–	+3	°C	Without calibration

7.7 AC Characteristics

The AC characteristics of the external interfaces are specified under these operating conditions:

$$T_A = 0 \text{ to } 70^\circ\text{C}$$

$$V_{DDP} = 3.3 \text{ V} \pm 5\%$$

$$V_{SS} = 0 \text{ V}$$

The timing measurements are made at minimum V_{IH} for a logical 1 and at maximum V_{IL} for a logical 0. See [Table 42](#) and [Table 43](#) for more details.

[Figure 17](#) shows the AC testing input/output waveforms. The load capacitors are according to the specific interface standard. All non-specified interfaces use 30 pF as assumed loading.

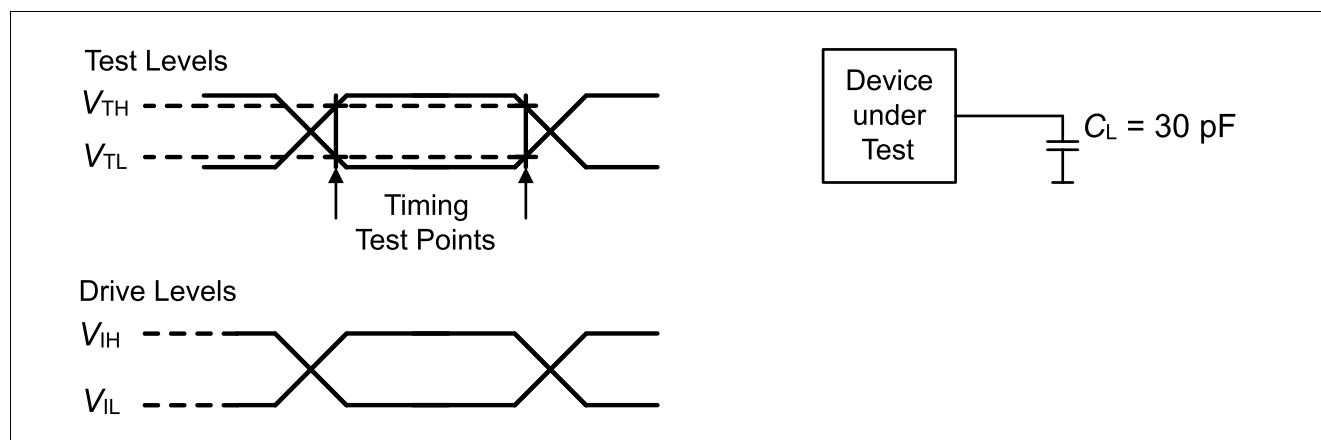

Figure 17 Input/Output Waveform for AC Tests

7.7.1 Power Up Sequence

All V_{HIGH} , V_{PH} , V_{DDA} , V_P , and V_{LOW} are supplied externally.

In this section, for the sake of simplicity:

- All 3.3 V supplies are represented as V_{HIGH} .
- All 1.8 V supplies are represented as V_{PH} .
- All 1.2 V supplies are represented as V_{DDA} .
- The 0.8 V analog supply of SerDes is represented as V_P .
- The rest of the 0.8 V supplies are represented as V_{LOW} .

All the supply domains V_{HIGH} , V_{PH} , V_{DDA} , V_P , and V_{LOW} , and the input reference clock must be stabilized before releasing the reset HRSTN.

There is no known voltage rail power up sequence except that V_{HIGH} must be ramped up and stable before V_{PH} is ramped up, V_{LOW} must be ramped up and stable before V_P is ramped up, and V_{LOW} must be ramped up and stable before V_{PH} is ramped up. MaxLinear recommends implementing the power-up sequence defined in the reference board. Refer to the relevant hardware documentation available at <https://maxlinear.com/myMxL> for more information on the power circuitry.

The MxL86288L supports an asynchronous hardware reset HRSTN. [Table 45](#) lists the timing requirements of the power supply pins. The timings refer to the signal sequence waveforms depicted in [Figure 18](#).

When PS_MDIO_VOLTAGE is low, V_{DDP} is treated as V_{PH} .

When PS_MDIO_VOLTAGE is high, V_{DDP} is treated as V_{HIGH} .

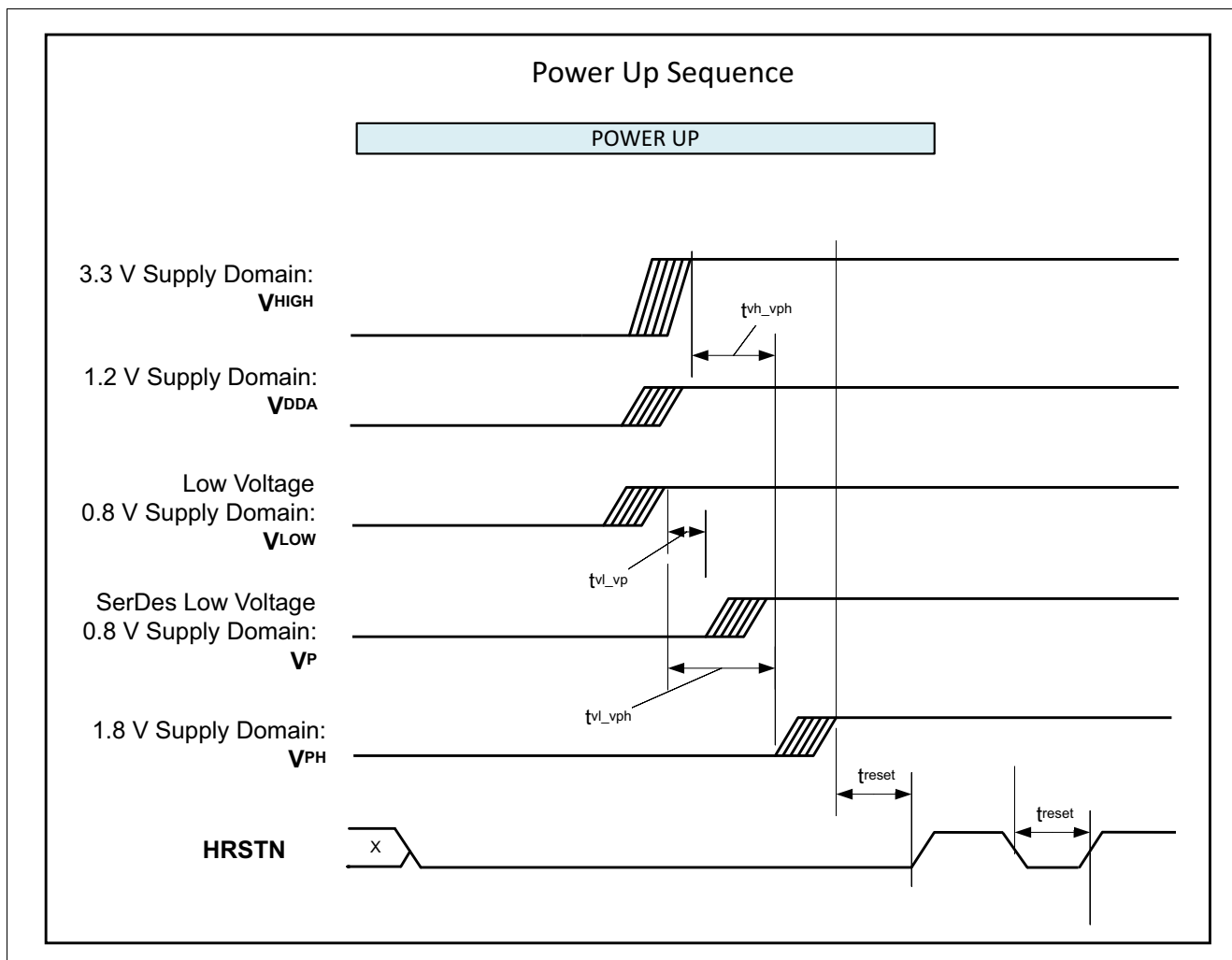

Figure 18 Timing Diagram for the Reset Sequence

Table 45 Power Supply Timings

Parameter	Symbol	Values			Unit	Note / Test Condition
		Min.	Typ.	Max.		
Delay between V_{HIGH} and V_{PH} Domains Voltage Ramp Up	t_{vh_vph}	50	-	-	μs	The V_{PH} voltage must never be higher than V_{HIGH} voltage
Delay between V_{LOW} and V_P Domains Voltage Ramp Up	t_{vl_vp}	1	-	-	μs	The V_P voltage must never power up before V_{LOW} voltage.
Delay between V_{LOW} and V_{PH} Domains Voltage Ramp Up	t_{vl_vph}	50	-	-	μs	The V_{PH} voltage must never power up before V_{LOW} voltage.
Reset Time after all Voltage Domains are Stabilized	t_{reset}	100	-	-	ns	HRSTN must be released after the power supplies stabilized.

7.7.2 Input Clock

Table 46 lists the input clock requirements when not using a crystal, for example when an external reference clock is injected into the XTAL1 pin of the MxL86288L, such as nominal frequency, frequency deviation, duty cycle, and signal characteristics. When a crystal is applied to generate the reference clock using the integrated XO, the clock requirements stated here are explicitly met as long as the specification for the crystal is satisfied.

Table 46 AC Characteristics of Input Clock on XTAL1 Pin

Parameter	Symbol	Values			Unit	Note / Test Condition
		Min.	Typ.	Max.		
Frequency with 25 MHz Input	f_{clk25}	–	25.0	–	MHz	–
Frequency with 50 MHz Input	f_{clk50}	–	50.0	–	MHz	–
Frequency with 156.25 MHz Input	f_{clk156}	–	156.25	–	MHz	–
Frequency Deviation ¹⁾		-50.0	–	+50.0	ppm	–
Duty Cycle		40.0	50.0	60.0	%	–
Rise/Fall Times with 25 MHz Input		–	–	10.0	ns	25 MHz
Rise/Fall Times with 50 MHz Input		–	–	5.0	ns	50 MHz
Rise/Fall Times with 156.25 MHz Input		–	–	1.0	ns	156.25 MHz
Input Long Term Jitter (Jrms)		–	–	2.0	ps	1 kHz to 10 MHz
Input Voltage Swing		300.0	–	–	mV	Peak to Peak value
Input Voltage		0	–	1.8	V	–

1) Including the frequency stability tolerance due to temperature, and aging effects over the product lifetime.

7.7.3 Power Supply Rail Requirements

Table 47 lists the required characteristics of the power supplies. The definitions of the power supply rails are the same as that described in [Section 7.7.1](#).

Table 47 AC Characteristics of the Power Supply

Parameter	Symbol	Values			Unit	Note / Test Condition
		Min.	Typ.	Max.		
Power Supply Ripple on V_P	R_{VP}	–	–	40.0	mV	Peak to Peak value See Figure 19 .
Power Supply Ripple on V_{LOW}	R_{VLOW}	–	–	40.0	mV	Peak to Peak value
Power Supply Ripple on V_{DDA}	R_{VDDA}	–	–	50.0	mV	Peak to Peak value
Power Supply Ripple on V_{HIGH}	R_{VHIGH}	–	–	50.0	mV	Peak to Peak value
Power Supply Ripple on V_{PH}	R_{VPH}	–	–	50.0	mV	Peak to Peak value Max. 18 mV peak to peak for any noise in 200 kHz to 100 MHz range. See Figure 20 .

7.7.3.1 V_P AC and DC Power Supply Recommendations

This section contains the V_P supply power requirements.

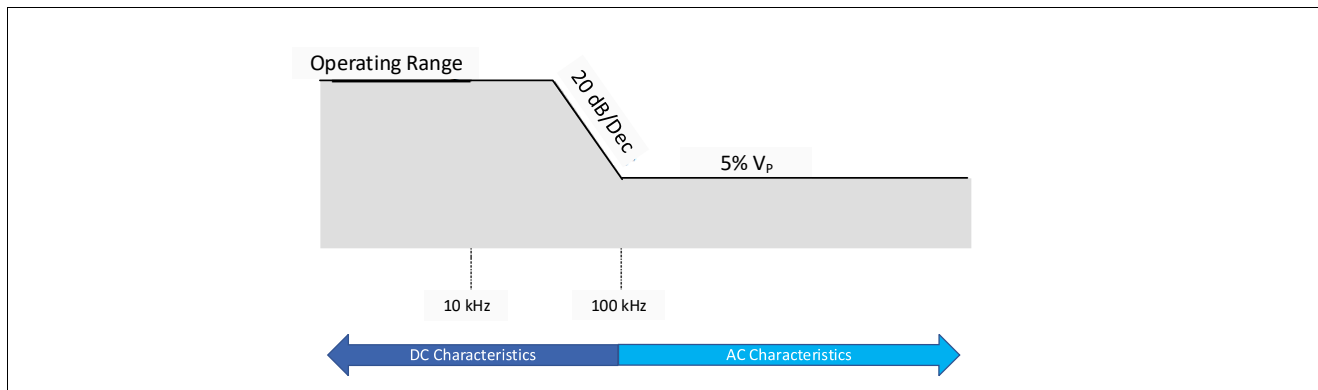

Figure 19 DC and AC Characteristics for V_P Supply

DC Characteristics

- Operating range: See the range of V_P in [Table 38](#)
- Frequency range: 0 to 100 kHz
- Recommendations:
 - The overshoot or undershoot of the low-frequency supply caused by the board filter network should be lower than 100 kHz.
 - The overall DC budget should account for the low frequency overshoot/undershoot in addition to the board plus package IR drop.
 - There is a transition zone between 10 kHz and 100 kHz in which it is possible for the supply noise to increase as the frequency decreases at a rate of 20 dB/Dec up to the maximum of the operating range.

AC Characteristics

- Max 5% (peak-to-peak) of the DC level for all noise greater than 100 kHz
- Recommendations:
 - A switching supply can be used until the overall noise limits (including, the self noise) are met.

7.7.3.2 V_{PH} AC and DC Power Supply Recommendations

This section contains the V_{PH} supply power requirements.

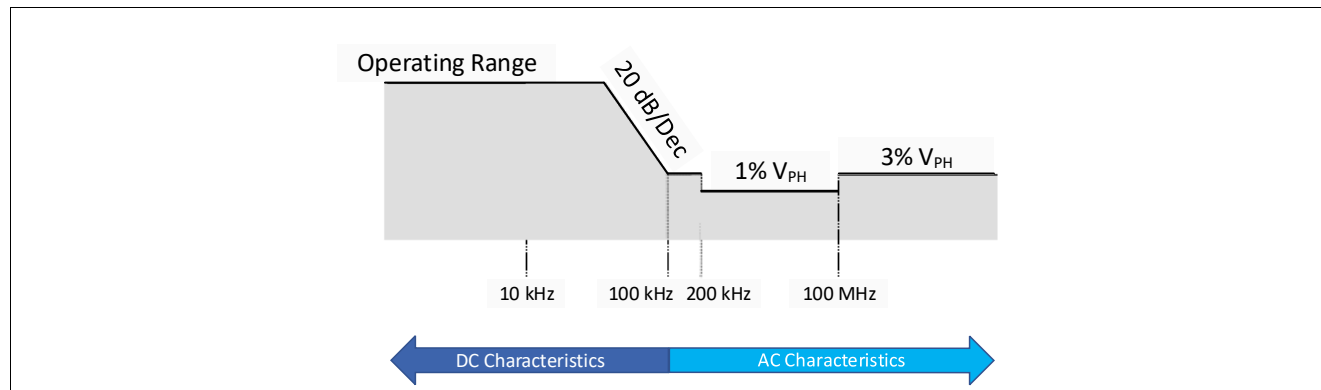

Figure 20 DC and AC Characteristics for V_{PH} Supply

DC Characteristics

- Operating range: See the range of V_{PH} in [Table 38](#)
- Frequency range: 0 to 100 kHz
- Recommendations:
 - The overshoot or undershoot of the low-frequency supply caused by the board filter network should be lower than 100 kHz.
 - The overall DC budget should account for the low frequency overshoot/undershoot in addition to the board plus package IR drop.
 - There is a transition zone between 10 kHz and 100 kHz in which it is possible for the supply noise to increase as the frequency decreases at a rate of 20 dB/Dec up to the maximum of the operating range.

AC Characteristics

- 100 kHz to 200 kHz: A maximum value of 3% ripple (peak-to-peak) of the DC level is allowed for all noise in this region.
- 200 kHz to 100 MHz: A maximum value of 1% ripple (peak-to-peak) of the DC level is allowed in this region.
- 100 MHz and above: A maximum value of 3% ripple (peak-to-peak) of the DC level is allowed for all noise in this region.
- Recommendations:
 - Use an LDO as a switching supply.
 - When using a switching power supply for V_{PH} , ensure that the 200 kHz to 100 MHz ripple requirements are met. Switching power supplies' tone and harmonics typically occur in this region.
 - Do not share this power rail directly with any other noisy circuitry.
 - Follow the relevant hardware documentation available at <https://maxlinear.com/myMxL> on the power circuitry.

7.7.4 MDIO Slave Interface

Figure 21 shows a timing diagram of the MDIO slave interface for a clock cycle in the read, write, and turnaround mode, respectively. The timing measures are annotated. **Table 48** summarizes the defined absolute values.

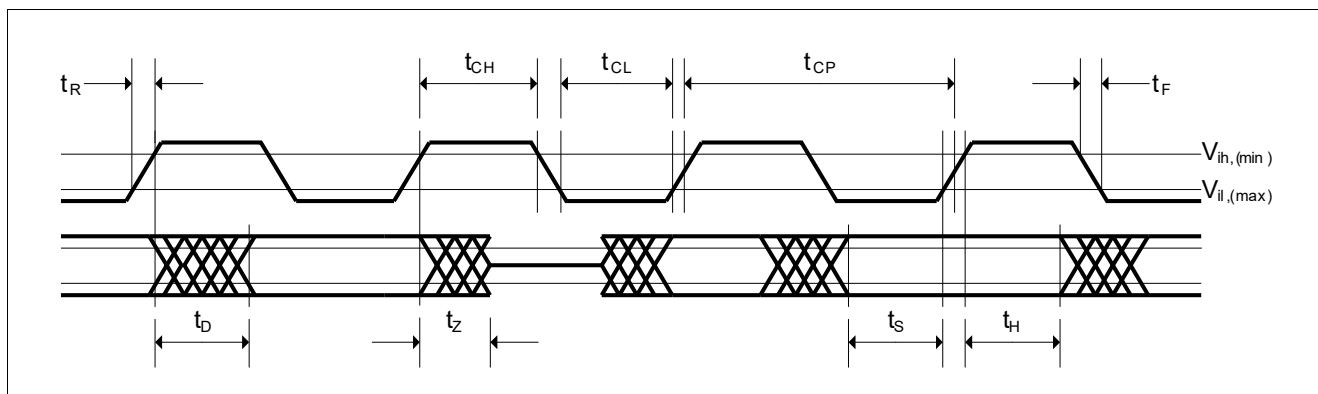

Figure 21 Timing Diagram for the MDIO Slave Interface

Table 48 Timing Characteristics of the MDIO Slave Interface

Parameter	Symbol	Values			Unit	Note / Test Condition
		Min.	Typ.	Max.		
MDC High Time	t_{CH}	10.0	–	–	ns	The MDC signal must conform to the specified MDC timings when measured at the MxL86288L's MDC_S pin.
MDC Low Time	t_{CL}	10.0	–	–	ns	
MDC Clock Period	t_{CP}	40.0	400.0	–	ns	
MDC Clock Frequency ¹⁾	t_{CP}	–	2.5	25.0	MHz	
MDC Rise Time	t_R	–	–	5.0	ns	
MDC Fall Time	t_F	–	–	5.0	ns	
MDIO Input Setup Time Subject to \uparrow MDC	t_S	10.0	–	–	ns	MxL86288L Receive
MDIO Input Hold Time Subject to \uparrow MDC	t_H	10.0	–	–	ns	MxL86288L Receive
MDIO Output Delay Time Subject to \uparrow MDC	t_D	0.0	–	10	ns	MxL86288L Transmit
Standard at 2.5 MHz						
MDIO Output Delay Subject to \uparrow MDC	t_D	0.0	–	300.0	ns	PHY Transmit

1) The MDC clock supports a range of frequencies up to 25 MHz. The default/typical frequency is 2.5 MHz.

7.7.5 Quad Serial Peripheral Interface (QSPI)

Figure 22 shows the QSPI master timing.

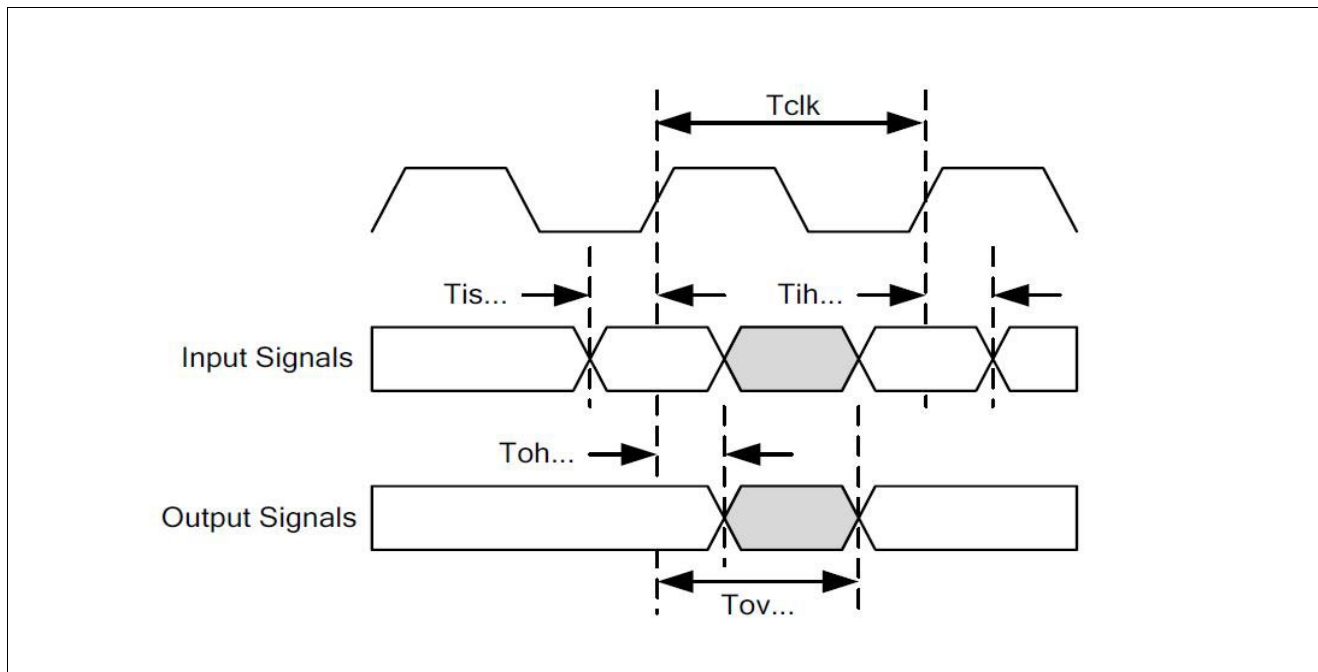

Figure 22 QSPI Master Interface Timing

Table 49 QSPI Interface Timing Parameters

Parameter	Symbol	Values			Unit	Note / Test Condition
		Min.	Typ.	Max.		
Master Mode						
TX Data Output Hold	T_{oh}	5%	–	–	Tclk	For Tclk = 20 ns
Tx Data Output Delay	T_{ov}	0	–	50%	Tclk	For Tclk = 20 ns
Rx Data Input Setup time	T_{is}	35%	–	–	Tclk	For Tclk = 20 ns
Rx Data Hold Time	T_{ih}	5%	–	–	Tclk	For Tclk = 20 ns
SPI Clock Period (Master Mode)	T_{clk}	9.846	–	–	ns	Maximum 101.5625 MHz
SPI Clock Rising	S_7	0.1	–	–	V/ns	–
SPI Clock Falling	S_6	0.1	–	–	V/ns	–

7.7.6 I²C Interface

Figure 23 shows the I²C interface timing.

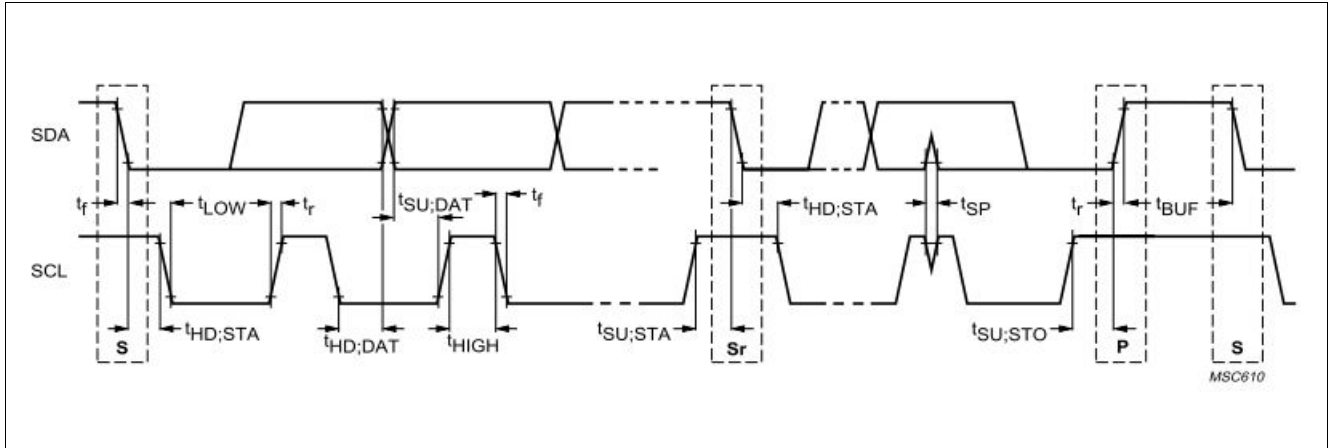

Figure 23 I²C Timing

Table 50 describes the timing values.

Table 50 I²C Timing

Parameter	Symbol	Values			Unit	Note / Test Condition
		Min.	Typ.	Max.		
SCL Frequency	f_{SCL}	0	–	100	kHz	–
Setup Time Data to Shift Clock	$t_{SU,DAT}$	250	–	–	ns	–
Hold Time Data to Shift Clock	$t_{HD,DAT}$	0	–	3.45	μ s	–
Setup Time START to Shift Clock	$t_{SU,STA}$	4700	–	–	ns	–
Hold Time START, STOP to Shift Clock	$t_{HD,STA/STO}$	4.0	–	–	μ s	–
Low Time	t_{LOW}	4700	–	–	ns	–
High Time	t_{HIGH}	4000	–	–	ns	–
Rising Time	t_r	–	–	1000	ns	–
Falling Time	t_f	–	–	300	ns	–
Bus Free Time	t_{BUF}	4700	–	–	ns	–

7.7.7 JTAG Interface

The JTAG test interface is used for debugging the CPU and boundary scan.

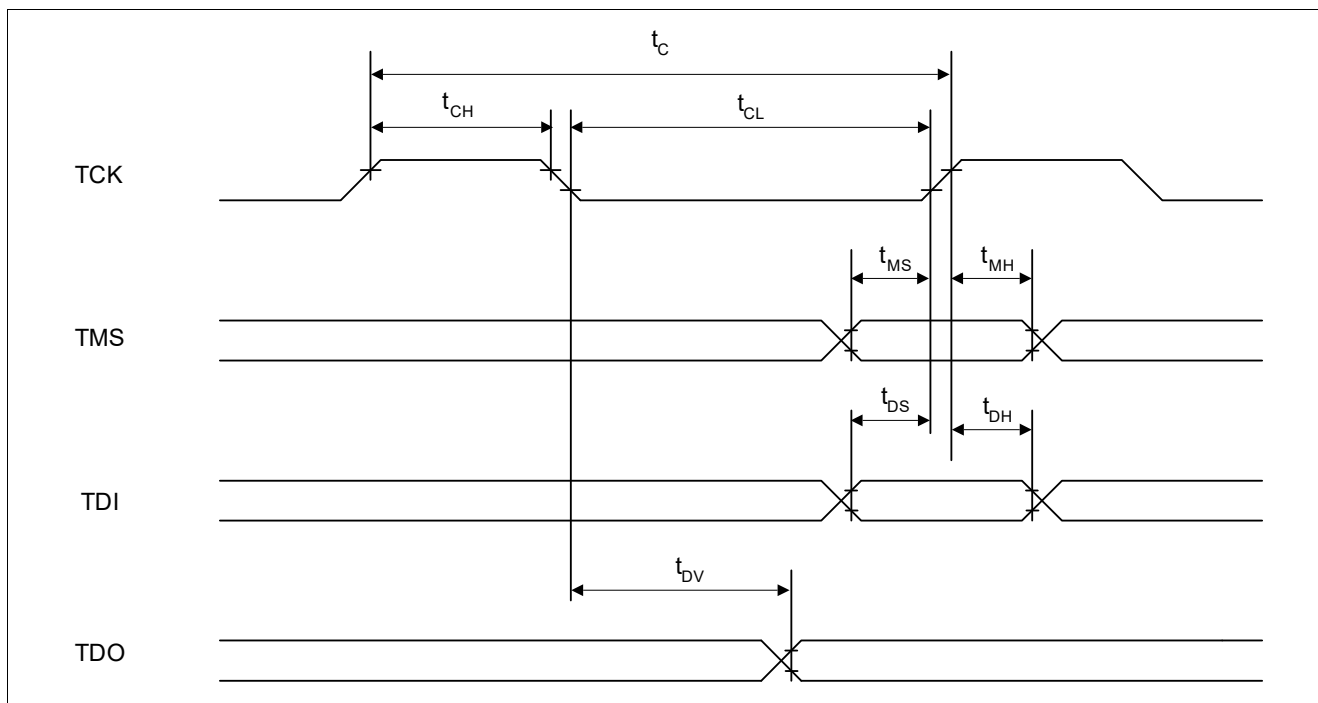

Figure 24 Test Interface Timing

[Table 51](#) and [Table 52](#) describe the timing values for the test interface.

Table 51 Test Interface Clock

Parameter	Symbol	Values			Unit	Note / Test Condition
		Min.	Typ.	Max.		
TCK Clock Period	t_C	100	–	–	ns	–
TCK High Time	t_{CH}	40	–	–	ns	–
TCK Low Time	t_{CL}	40	–	–	ns	–

Table 52 JTAG Timing

Parameter	Symbol	Values			Unit	Note / Test Condition
		Min.	Typ.	Max.		
TMS Setup Time	t_{MS}	40	–	–	ns	–
TMS Hold Time	t_{MH}	40	–	–	ns	–
TDI Setup Time	t_{DS}	40	–	–	ns	–
TDI Hold Time	t_{DH}	40	–	–	ns	–
Hold: TRSTN After TCK	t_{HD}	10	–	–	ns	–
TDO Valid Delay	t_{DV}	–	–	60	ns	–

7.7.8 USXGMII Interface Characteristics

This section describes the AC characteristics of the USXGMII interface on the MxL86288L.

The USXGMII interface characteristics are described in:

- USXGMII transmit characteristics ([Section 7.7.8.1](#))
- USXGMII receive characteristics ([Section 7.7.8.2](#))

7.7.8.1 USXGMII Transmit Characteristics

[Table 53](#) shows the requirements of the USXGMII interface on the MxL86288L.

Table 53 Transmit Characteristics of the USXGMII

Parameter	Symbol	Values			Unit	Note / Test Condition
		Min.	Typ.	Max.		
Reference Differential Impedance	Z_d	–	100	–	Ω	–
Termination Mismatch	R_M	–	–	5	%	–
DC Common Mode Voltage	V_{cm}	0	–	3.6	V	–
Output Rise and Fall Time	t_{RH}, t_{FH}	24	–	–	ps	20%→80%
Output AC Common Mode Voltage	–	–	–	15	mV	mV (RMS)
Differential Output Return Loss ¹⁾	SDD22	20	–	–	dB	0.05-0.1 GHz
		10	–	–	dB	0.1-7.5 GHz
		–	–	–		7.5-15 GHz
Common Mode Output Return Loss ²⁾	SCC22	6	–	–	dB	0.1-15 GHz

1) Return loss given by equation $SDD22(dB) = 10 - 16.6 \log_{10}(f/7.5)$, with f in GHz.

2) Common mode reference impedance is 25 Ω common mode return loss helps absorb reflections and noise for EMI.

7.7.8.2 USXGMII Receive Characteristics

[Table 54](#) shows the requirements of the USXGMII interface on the MxL86288L.

Table 54 Receive Characteristics of the USXGMII

Parameter	Symbol	Values			Unit	Note / Test Condition
		Min.	Typ.	Max.		
Reference Differential Impedance	Z_d	–	100	–	Ω	–
Termination Mismatch	Z_M	–	–	5	%	–
AC Common Mode Voltage	–	–	–	25	mV	mV (RMS)
Differential Output Return Loss ¹⁾	SDD11	20	–	–	dB	0.05-0.1 GHz
		10	–	–	dB	0.1-7.5 GHz
		–	–	–		7.5-15 GHz
Common Mode Input Return Loss ²⁾	SCC11	6	–	–	dB	0.1-15 GHz
Differential to Common Mode Input Conversion ²⁾	SCD11	12	–	–	dB	0.1-15 GHz

1) Return loss given by equation $SDD11(dB) = 10 - 16.6 \log_{10}(f/7.5)$, with f in GHz.

2) Common mode reference impedance is 25 Ω . SCD11 relates to conversion of differential to common mode and the associated generation of EMI.

7.7.9 Crystal Specification

The 25 MHz crystal must follow the specification given in [Table 55](#).

Table 55 Specification of the Crystal

Parameter	Symbol	Values			Unit	Note / Test Condition
		Min.	Typ.	Max.		
Frequency with 25 MHz Input	f_{clk25}	–	25.0	–	MHz	–
Total Frequency Stability	–	-50	–	+50	ppm	Refers to the sum of all effects: such as general tolerance, aging, and temperature dependency
Series Resonant Resistance	–	–	–	40	Ω	–
Drive Level	–	–	0.1	0.2	mW	–
Load Capacitance	C_L	16	–	26	pF	–
Shunt Capacitance	C_0	–	–	7	pF	–

7.8 External Circuitry

This section specifies the component characteristics of the external circuitry connected to the TPIs of the MxL86288L.

7.8.1 Twisted-Pair Common-Mode Rejection and Termination Circuitry

Figure 25 shows the external circuitry necessary to properly terminate the common mode of the TPI.

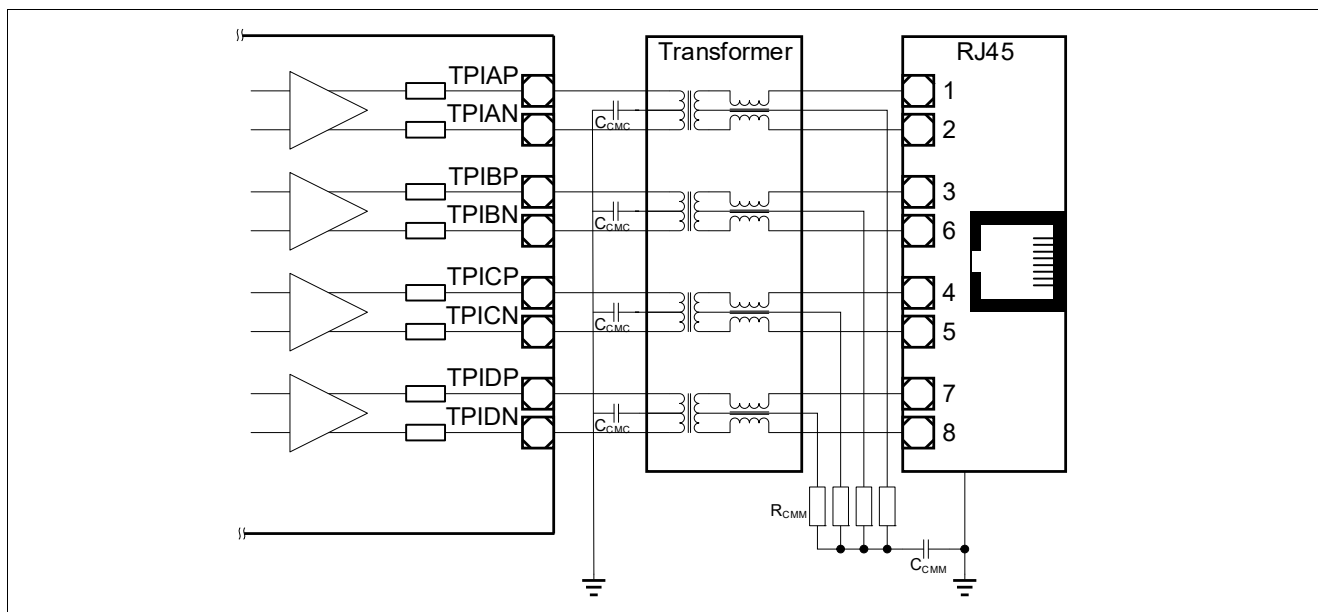

Figure 25 Twisted Pair Common-Mode Rejection and Termination Circuitry

Table 56 defines the component values and their supported tolerances.

Table 56 Electrical Characteristics for Common-Mode Rejection and Termination Circuitry

Parameter	Symbol	Values			Unit	Note / Test Condition
		Min.	Typ.	Max.		
Common-Mode Decoupling Capacitance (Media End)	C_{CMM}	800	1000	1200	pF	±15%, 3 kV
Common-Mode Decoupling Capacitance (Chip End)	C_{CMC}	80	100	120	nF	±15%, 25 V
Common-Mode Termination Resistance (Media End)	R_{CMM}	67.5	75	82.5	Ω	±5%

7.8.2 Transformer (Magnetics)

This section specifies the required electrical characteristics of the transformer¹⁾ devices that are supported. The specifications listed here guarantee proper operation according to IEEE 802.3 [2].

Figure 26 depicts a typical Gigabit Ethernet capable transformer device.

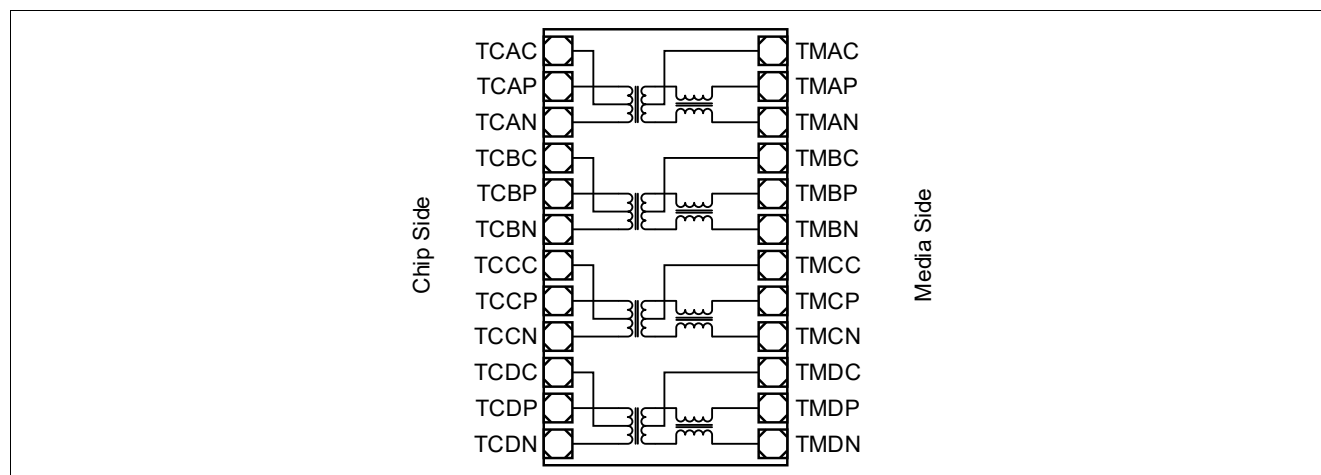

Figure 26 Schematic of an Ethernet Transformer Device

Table 57 lists the characteristics of the supported transformer devices. These characteristics represent the minimum values for achieving standard performance. Since the transformer significantly impacts the link performance, it is possible to increase the loop reach by selecting transformers with improved parameters.

Table 57 Electrical Characteristics for Supported Transformers (Magnetics)

Parameter	Symbol	Values			Unit	Note / Test Condition
		Min.	Typ.	Max.		
Turns Ratio	1:tr	0.95	1.00	1.05		±5%
Differential-to-Common-mode Rejection	DCMR	40	–	–	dB	30 MHz
		35	–	–	dB	60 MHz
		30	–	–	dB	100 MHz
Crosstalk Attenuation	CTA	45	–	–	dB	30 MHz
		40	–	–	dB	60 MHz
		35	–	–	dB	100 MHz
Insertion Loss	IL	–	–	1	dB	1 MHz ≤ f ≤ 250 MHz
Return Loss	RL	16	–	–	dB	1 MHz ≤ f ≤ 40 MHz
Return Loss	RL	16-10*log ₁₀ (f/40)	–	–	dB	40 MHz ≤ f ≤ 250 MHz

1) Also often referred to as magnetics.

7.8.3 RJ45 Plug

Table 58 describes the electrical characteristics of the RJ45 plug to be used in conjunction with MxL86288L.

Table 58 Electrical Characteristics for Supported RJ45 Plugs

Parameter	Symbol	Values			Unit	Note / Test Condition
		Min.	Typ.	Max.		
Crosstalk Attenuation	CTA	45	–	–	dB	30 MHz
		40	–	–	dB	60 MHz
		35	–	–	dB	100 MHz
Insertion Loss	IL	–	–	1	dB	1 MHz ≤ f ≤ 250 MHz
Return Loss	RL	16	–	–	dB	1 MHz ≤ f ≤ 40 MHz
Return Loss	RL	16-10*log ₁₀ (f/40)	–	–	dB	40 MHz ≤ f ≤ 250 MHz

8 Package Outline

The product is assembled in a package, which complies with regulations requiring lead free material. [Table 59](#) lists the parameters generated in accordance with JEDEC JESD51 standards [\[3\]](#).

Table 59 JEDEC Thermal Resistance Package Parameter - Compact 2-R Model Network

Item	Name/Value
Thermal Resistance - Junction to Case Top	$R_{th, Jctop} = 2.72 \text{ K/W}$
Minimum Thermal Resistance - Junction to 0 mm from package edge on PCB	$R_{th, JB} = 2.75 \text{ K/W}$

Table 60 Stress Force Package Parameter

Item	Value
Force	1.939 kg
Pressure	1.346528 kg/cm ²
	19.15207 PSI

Figure 27 shows the mechanical drawings for this package. The dimensions are in millimeters.

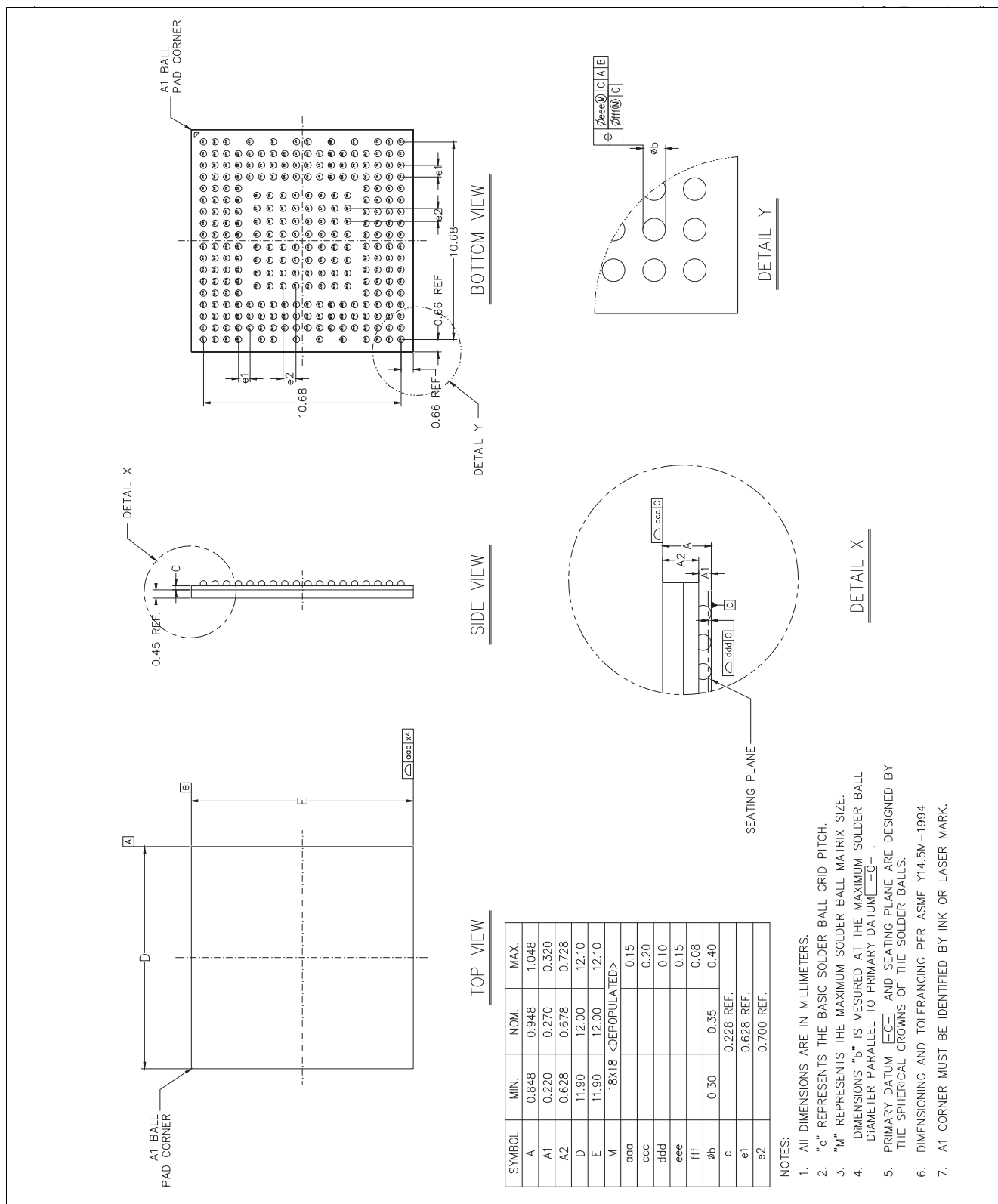

Figure 27 PG-FCLBGA-277 12 mm x 12 mm Package Outline

9 Product Ordering Information

Table 61 provides the product ordering information.

Table 61 Product and Package Naming

Marketing Part Number	Ordering Part Number	Shipping Format	Package	Device Number ¹⁾	Device Revision Number ²⁾	PHY Identifier ³⁾
MxL86288L	MXL86288L-ABB-T	Tray	PG-FCLBGA-277	0x15	0x8	0x5558

1) LDN field in CL22 and CL45 registers.

2) LDRN field in CL22 and CL45 registers.

3) PHY Identifier 2 register 16-bit value.

Note: For more information about part numbers, as well as the most up-to-date information and additional information on environmental rating, go to <https://www.maxlinear.com/products/interface/ethernet>.

Literature References

[1] Ethernet PHY MxL862xx Configuration User Guide Rev. 1.0 (in preparation)

Attention: Refer to the latest revisions of the documents.

Standards References

- [2] IEEE 802.3-2022: Carrier Sense Multiple Access with Collision Detection (CSMA/CD) Access Method and Physical Layer Specifications, IEEE Computer Society, May 2022
<https://standards.ieee.org/ieee/802.3/10422/>
- [3] JEDEC standard, JESD 51: Methodology for the Thermal Measurement of Component Packages (Single Semiconductor Device), December 1995
<https://www.jedec.org/standards-documents/docs/jesd-51>
- [4] Universal SXGMII Interface for a Single MultiGigabit Copper Network Port, Revision 2.4, Cisco Systems, July 30th 2019
- [5] Cisco USXGMII Multiport Copper PHY Specification, EDCS-1517762, Version 2.15, May 11th, 2017
- [6] Cisco USXGMII Single-port Copper PHY Specification, EDCS-1150953, Version 2.4, May 23rd 2016
- [7] The I2C-Bus Specification Version 2.1, January 2000
- [8] Negotiated Fast Retrain, Revision 2.0, Cisco Systems, June 10th, 2011
- [9] IEEE 802.1Qbu: Frame Preemption, IEEE 802.1 working group, October 7th 2015
- [10] Microsoft Security Development Lifecycle
<https://www.microsoft.com/en-us/securityengineering/sdl/practices>

Terminology

A

ADS	Auto-Downspeed
AFE	Analog Front End
ANEG	Auto-Negotiation
ANSI	American National Standards Institute
ASP	Analog Signal Processing

B

BW	Bandwidth
----	-----------

C

Cat 5	Category 5 Cabling
CDB	Clock Distribution Block
CDR	Clock and Data Recovery
CML	Current Mode Logic

D

DSP	Digital Signal Processing
DWRR	Deficit Weighted Round Robin

E

EEE	Energy-Efficient Ethernet
EEPROM	Electrically Erasable Programmable ROM
EMI	Electromagnetic Interference
ESD	Electrostatic Discharge

F

FCA	Flash Configuration Area
FLP	Fast Link Pulse

G

GMII	Gigabit Media-Independent Interface
GPIO	General Purpose Input/Output

H

HBM	Human Body Model
-----	------------------

I

I ² C	Internally Integrated Circuit Interface (also I2C)
IC	Integrated Circuit
IEEE	Institute of Electrical and Electronics Engineers

J

JTAG	Joined Test Action Group
------	--------------------------

L

LAN	Local Area Network
LED	Light Emitting Diode

LJPLL	Low Jitter Phase-Locked Loop
LPI	Low Power Idle
LSB	Least Significant Bit
M	
MAC	Media Access Controller
MDI	Media-Dependent Interface
MDIO	Management Data Input/Output
MDIX	Media-Dependent Interface Crossover
MMD	MDIO Manageable Device
MSB	Most Significant Bit
N	
NLP	Normal Link Pulse
O	
OSI	Open Systems Interconnection
OUI	Organizationally Unique Identifier
P	
PCB	Printed Circuit Board
PCS	Physical Coding Sublayer
PD	Power Down
PHY	Physical Layer (device)
PLL	Phase-Locked Loop
PMA	Physical Media Attachment
Q	
QSPI	Quad Serial Peripheral Interface
R	
Rx	Receive
S	
SerDes	Serializer-Deserializer
SFP	Small Form-Factor Pluggable
SMD	Surface Mounted Device
SoC	System on Chip
STA	Station Management Entity (MAC SoC)
SVN	Security Version Number
T	
TLE	Transformerless Ethernet
TPG	Test Packet Generator
TPI	Twisted Pair Interface
Tx	Transmit
U	
USXGMII	Universal Serial Multi(x) Gigabit Media Independent Interface

W

WoL Wake-on-LAN

X

XO Crystal Oscillator