

The 1588v2 Gigabit Ethernet Switch Device for Switches and Gateways

PRODUCTS

GSW120	4-port Gigabit Ethernet QoS switch with two Ethernet PHY, one 1G RGMII, one 2.5G SGMII+, and one management port
GSW140	6-port Gigabit Ethernet QoS switch with four Ethernet PHY, one 1G RGMII, one 2.5G SGMII+, and one management port
GSW141	6-port Gigabit Ethernet QoS switch with four Ethernet PHY, one 1G RGMII, one 1G SGMII, and one management port

FEATURES

- Two (GSW120) or four (GSW140 and GSW141) integrated PHY
 - 10BASE-TE, 100BASE-TX, and 1000BASE-T
 - 802.3az Energy-Efficient Ethernet
- Single RGMII interface with delay compensation
- 2.5G SGMII+ (GSW120 and GSW140) or 1G SGMII (GSW141) uplink port
- QoS support with up to 16 traffic classes based on port, 802.1P, IP DSCP/ToS, and multiple fields
- 4K 802.1Q VLAN and VLAN Q-in-Q insertion, removal, and translation
- Hardware IGMP V1/2 and MLD V1 snooping
- Broadcast storm control and ingress bandwidth control
- Egress rate shaping and WFQ-strict priority combined scheduling
- Switch buffer reservation for congestion management
- Cable diagnostics: cable open/short detection and cable length estimation
- Test loops and analog self-test
- Up to three LEDs per PHY
- 25MHz crystal
- 2K MAC addresses
- 64 ACL rules
- Up to 32 class of service queues
- Up to 16 queues per port
- 32 single rate shapers
- 16 single rate three color meters
- 802.1p and IP DSCP/ToS remarking
- Authentication support according to IEEE 802.1X port authentication
- Spanning tree/rapid spanning tree and 16 STP instances per port
- Port mirroring
- Precise time stamping indication according to IEEE 1588 Version 2
- 3.3V and 1.1V power supply

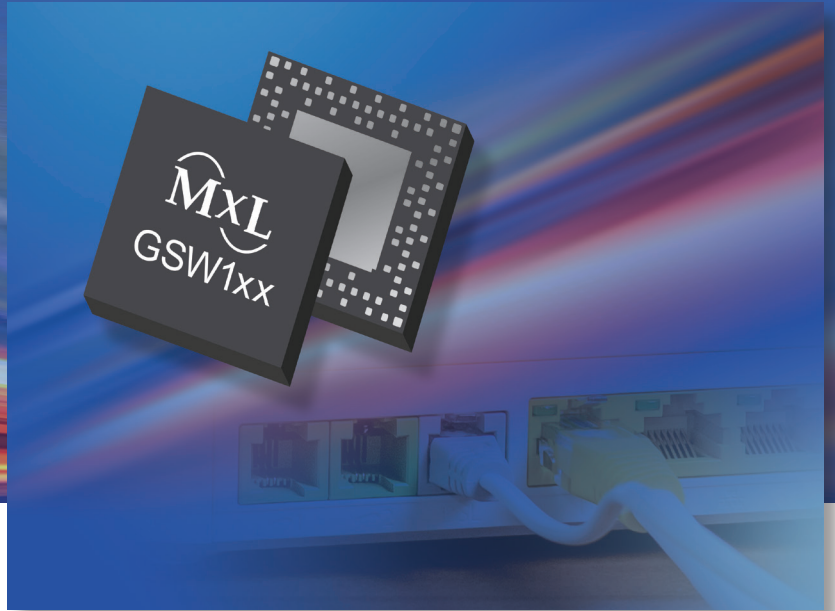

The GSW120, GSW140, and GSW141 (GSW1xx) devices are highly integrated, non-blocking four-port (GSW120) or six-port (GSW140 and GSW141) Gigabit Ethernet QoS switches with two (GSW120) or four (GSW140 and GSW141) Ethernet PHY, one 1G RGMII, one 2.5G SGMII+ (GSW120 and GSW140) or one 1G SGMII (GSW141), and one management port.

The GSW1xx device complies with 10BASE-TE, 100BASE-TX, and 1000BASE-T standards. Support of *Energy-Efficient Ethernet 802.3az* reduces power consumption further in idle state. A smart LED brightness control logic is integrated for additional power saving. LED brightness can be adjusted either by an external push button or varies dynamically depending on the intensity of the light with an external light sensor.

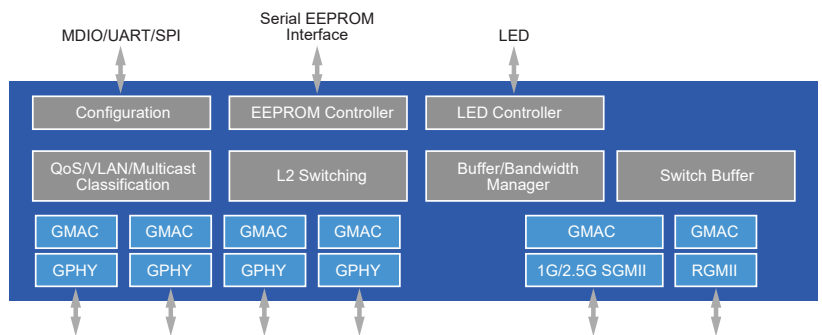

GSW140 Block Diagram

GSW1xx Gigabit Ethernet Switch

The GSW1xx device is configurable through pin-strapping, by means of the MDIO interface, UART interface, SPI interface, or optionally by connecting an external EEPROM. Integrated QoS technology prioritizes switch traffic for different classes of applications, for example, VoIP, video, audio, and data based on port ID, 802.1p, IP DSCP/ToS, and multiple fields of the packet. *IEEE 1588v2* support enables highly accurate precision timing protocol applications.

The 1M Bits embedded packet storage SRAM is integrated with 9KB jumbo frame support.

The GSW1xx device features 4K entry VLAN table for 802.1Q VLAN operation and double VLAN tagging (Q-in-Q) translation. The device supports IGMP V1/2 and MLD V1 snooping for efficient use of network bandwidth.

SOLUTION HIGHLIGHTS

- Smart LED brightness control integrated for power saving
- Industry's smallest footprint MRQFN-105 8x8mm
- 2.5G SGMII+ uplink support (GSW120 and GSW140)
- IEEE 1588 Version 2* support

MAIN APPLICATIONS

- Home gateways
- Standalone switches plus 2.5G uplink

STANDARDS

- IEEE 802.3az: Energy-Efficient Ethernet
- IEEE 1588 Version 2

Application Examples

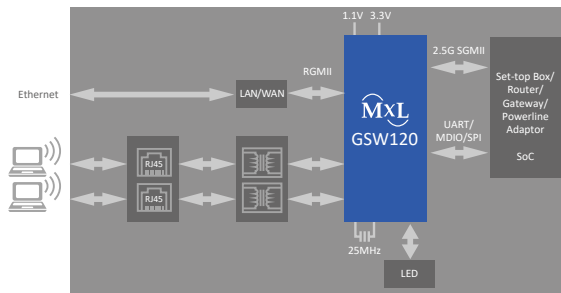

Home Gateway

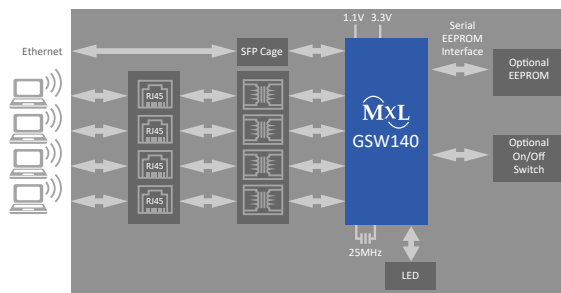

Standalone Desktop Switch with Optional Brightness On/Off Switch

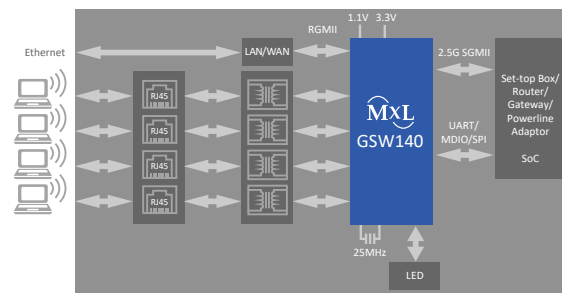

Home Gateway

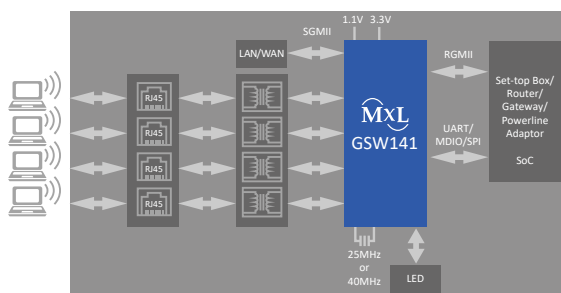

PUMA™ 6 Dual WAN, Router, and Gateway

GSW1xx Gigabit Ethernet Switch

Product Information

Product	Description	Ordering Code	Package
GSW120 Gigabit Ethernet Switch	4-port Gigabit Ethernet QoS switch with two Ethernet PHY, one 1G RGMII, one 2.5G SGMII+, and one management port	GSW120A3MC	MRQFN-105 (8x8)
GSW140 Gigabit Ethernet Switch	6-port Gigabit Ethernet QoS switch with four Ethernet PHY, one 1G RGMII, one 2.5G SGMII+, and one management port	GSW140A3MC	MRQFN-105 (8x8)
GSW141 Gigabit Ethernet Switch	6-port Gigabit Ethernet QoS switch with four Ethernet PHY, one 1G RGMII, one 1G SGMII, and one management port	GSW141A3MC	MRQFN-105 (8x8)



Corporate Headquarters:
5966 La Place Court
Suite 100
Carlsbad, CA 92008
Tel.: +1 (760) 692-0711
Fax: +1 (760) 444-8598
www.maxlinear.com

The content and information contained in this document is furnished for informational or general marketing purposes only, is subject to change without notice, and should not be construed as a commitment by MaxLinear, Inc. MaxLinear, Inc. assumes no responsibility or liability for any errors, inaccuracies, or incompleteness that may appear in the informational content contained in this guide.

Reproduction, in part or whole, without the prior written consent of MaxLinear, Inc. is prohibited. MaxLinear, the MaxLinear logo, and any MaxLinear trademarks; MxL, Full-Spectrum Capture, FSC, G.now, AirPHY, Puma, and AnyWAN are all trademarks of MaxLinear, Inc. or one of MaxLinear's subsidiaries in the U.S.A. and other countries. Other company trademarks and product names appearing herein are the property of their respective owners.

© 2020 MaxLinear, Inc. All rights reserved.