



MxL76503
18V 720kHz 3A Fast-PWM
Synchronous Step-Down
Converter
EVK User Manual

Revision History

Document No.	Release Date	Change Description
037-76503UMR01	August 8, 2025	Updated: <ul style="list-style-type: none">■ "MxL76503 EVK Simplified Block Diagram" figure.■ "Recommended Values of Components" table.■ "EVK Schematic"figure.■ "EVK PCB Layers" section.■ "EVK Bill of Materials" table.
037-76503UMR00	April 11, 2025	Initial release.

Table of Contents

Introduction	1
Quick EVK Set-Up and Start-Up	1
Factory Settings	1
Quick Start-Up.....	1
Ordering Information	2
Evaluation Kit Overview	2
System Set-Up	3
EN Options	3
V _{OUT} Selection	3
Test Set-Up and Result	4
Input and Output Connections.....	4
Start-Up Procedure	4
Start-Up	5
Shutdown	5
EVK Schematic	6
EVK PCB Layers	7
EVK Bill of Materials	10

List of Figures

Figure 1: Top View of the MxL76503 EVK	2
Figure 2: MxL76503 EVK Simplified Block Diagram	2
Figure 3: V_{IN} and V_{OUT} Connections of the MxL76503 EVK.....	4
Figure 4: MxL76503 Start-Up with a 3A Load	5
Figure 5: MxL76503 Shutdown with a 3A Load.....	5
Figure 6: EVK Schematic	6
Figure 7: EVK PCB Silkscreen Top	7
Figure 8: EVK PCB Silkscreen Bottom.....	7
Figure 9: EVK PCB Top Layer.....	8
Figure 10: EVK PCB Bottom Layer	8
Figure 11: EVK PCB Layer 2.....	9
Figure 12: EVK PCB Layer 3.....	9

List of Tables

Table 1: EVK Ordering Part Numbers	2
Table 2: Jumper JP1 Options for the EN Pin.....	3
Table 3: EN Threshold Specification	3
Table 4: Recommended Values of Components	3
Table 5: EVK Bill of Materials	10

Introduction

The MxL76503 evaluation kit (EVK) provides a platform to evaluate the features and performance of the MxL76503 synchronous step-down constant on-time (COT) buck converter. The MxL76503 provides a maximum load current rating of 3A with an input voltage range of 4.5V to 18V. It is packaged in a 6-pin SOT23-6L.

This document provides the EVK schematic (see [“EVK Schematic”](#) on page 6), PCB layout (see [“EVK PCB Layers”](#) on page 7), and bill of materials (see [“EVK Bill of Materials”](#) on page 10). They can help you with your design.

For more information, refer to the *MxL76503 Data Sheet* (285-76503DS). It includes a complete list of the device features, pinout, pin descriptions, typical performance characteristics, and external component calculations. This user manual is intended to be used in conjunction with the data sheet.

Quick EVK Set-Up and Start-Up

Factory Settings

The EVK has been set up with the following factory default configurations for quick set-up and operation:

- V_{IN} = 4.5V to 18V, optimized for a 12V input rail.
- V_{OUT} = 3.3V. For a different V_{OUT} selection, see [“ \$V_{OUT}\$ Selection”](#) on page 3.
- Maximum continuous I_{OUT} of 3A.
- Switching frequency of 720kHz.
- Forced continuous conduction mode (FCCM) or pulse-frequency modulation (PFM) mode. See [“Ordering Information”](#) on page 2.
- Built-in internal soft-start time of 1.2ms (typical).

Note: Do not exceed the device maximum load current rating.

Quick Start-Up

To quickly see the regulator in operation:

1. Use the factory settings and default configuration. If you wish to change any settings or components, do so before proceeding with the following steps. For more information, see [“System Set-Up”](#) on page 3.
2. Connect a turned-off power supply that is within the V_{IN} specification (from 4.5V to 18V, 12V typically) to the VIN pillar and to the GND pillar with short/thick leads. See the locations in [“Test Set-Up and Result”](#) on page 4.
3. Initially set to 0A, connect an electronic load not exceeding the maximum I_{OUT} (3A) to the VOUT pillar and to the GND pillar with short/thick leads. See the locations in [“Test Set-Up and Result”](#) on page 4.
4. Turn on the power supply and check V_{OUT} . The EVK should power up and regulate the output at 3.3V (factory setting).
5. Set or vary the load (do not exceed the maximum I_{OUT}) and check V_{OUT} and other desired performance levels, such as regulation and efficiency. For the result, see [“Test Set-Up and Result”](#) on page 4.

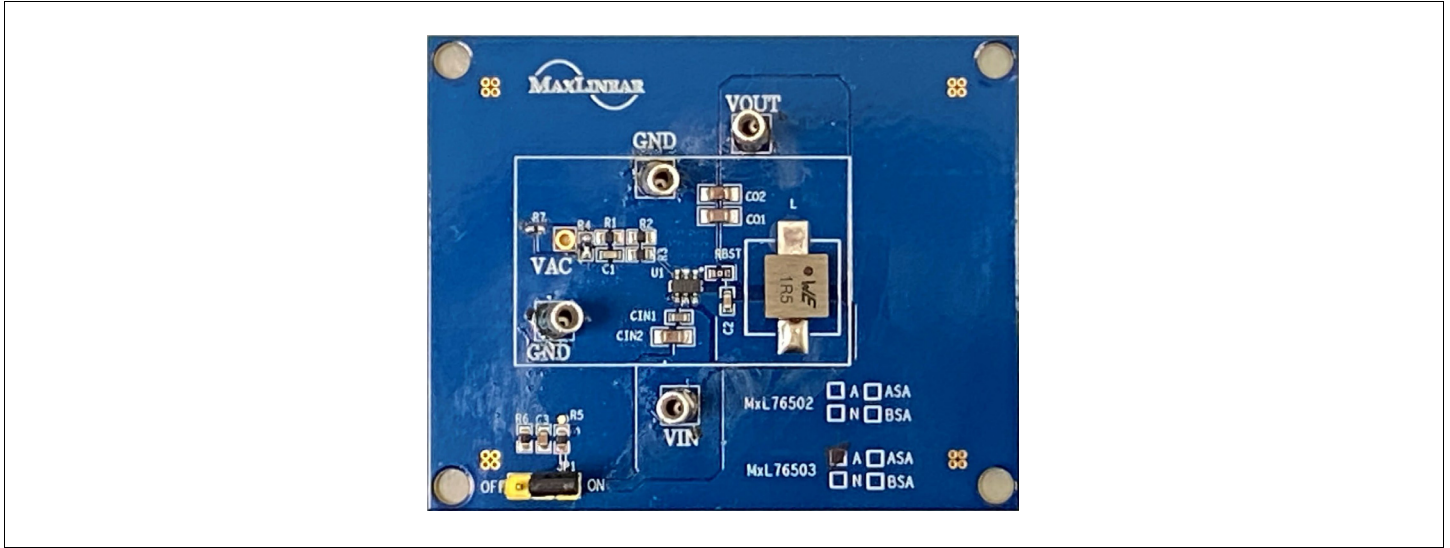

Figure 1: Top View of the MxL76503 EVK

Ordering Information

The following table lists the ordering part numbers for the evaluation kit.

Table 1: EVK Ordering Part Numbers

EVK Part Number	Maximum I_{OUT}	Default Output Voltage	Description
MXL76503A-EVK-1	3A	3.3V	EVK 3A step-down converter in FCCM mode
MXL76503N-EVK-1	3A	3.3V	EVK 3A step-down converter in PFM mode

Note: For the most up-to-date ordering information and additional information on environmental rating, go to www.maxlinear.com/MxL76503.

Evaluation Kit Overview

The following figure shows the EVK options for adjusting or testing.

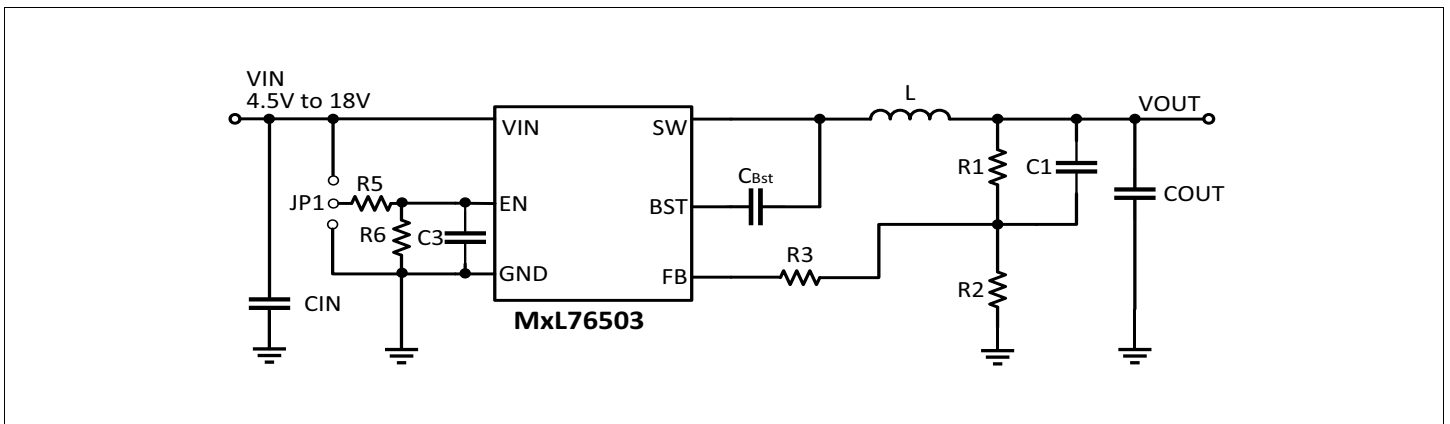

Figure 2: MxL76503 EVK Simplified Block Diagram

System Set-Up

EN Options

The following table lists the three options that the EN pin has reserved via JP1.

Table 2: Jumper JP1 Options for the EN Pin

Jumper Options	Description
Jumper 1-2	The enable (EN) pin is tied to GND, permanently disabling the channel.
Jumper 2-3 (default)	The EN pin is tied to V_{IN} and the channel is enabled at power-up
No jumper	The jumper is open, allowing EN to be controlled outside the EVK.

If you set the EN jumper JP1 as a *no jumper*, an external control signal is connected. Make sure that the EN threshold specification can be met for the external control signal.

Table 3: EN Threshold Specification

EN Pin Threshold		Condition	Minimum	Typical	Maximum
V_{EN_VIH}	Turn-on threshold	Rising	-	1.21V	-
V_{EN_VIL}	Turn-off threshold	Falling	-	1.11V	-

V_{OUT} Selection

The factory installed configuration of V_{OUT} is 3.3V. You can modify V_{OUT} by changing the low-side resistor (R2) of the feedback resistor divider according to:

$$R2 = \left(\frac{R1 \times 0.6}{V_{OUT} - 0.6} \right)$$

Where R1 is the high-side resistor of the feedback resistor divider, which has a nominal value of 100k Ω .

Changing the output voltage also affects loop stability. For proper loop compensation, MaxLinear recommends also modifying the inductance (L) and feed-forward capacitance (C1) values as listed in the following table, and using 1% resistors to maintain output voltage accuracy.

Table 4: Recommended Values of Components

V_{OUT}	L	R1	R2	R3	C1
5.0V	4.7 μ H	100k Ω	13.7k Ω	499 Ω –510 Ω	100pF–150pF
3.3V	3.3 μ H	100k Ω	22.1k Ω	499 Ω –510 Ω	100pF–180pF
1.8V	2.2 μ H	100k Ω	50.0k Ω	499 Ω –510 Ω	100pF–220pF
1.2V	1.5 μ H	100k Ω	100.0k Ω	499 Ω –510 Ω	100pF–220pF
1.0V	1.5 μ H	100k Ω	150.0k Ω	499 Ω –510 Ω	100pF–220pF
0.9V	1.5 μ H	100k Ω	200.0k Ω	499 Ω –510 Ω	150pF–220pF

Test Set-Up and Result

Input and Output Connections

MaxLinear recommends using a power supply of 3A and connect it to the VIN and GND pillars of the MxL76503 EVK via a pair of 21-AWG wires. Connect the output port at the VOUT and GND pillars to an electronic load or another load via a pair of 21-AWG wires, as shown in [Figure 3](#). The connecting wire should be as short as possible to reduce losses.

Note: Do not exceed the maximum output current capability of 3A.

For the V_{IN} and V_{OUT} test points, MaxLinear recommends measuring both input and output capacitance.

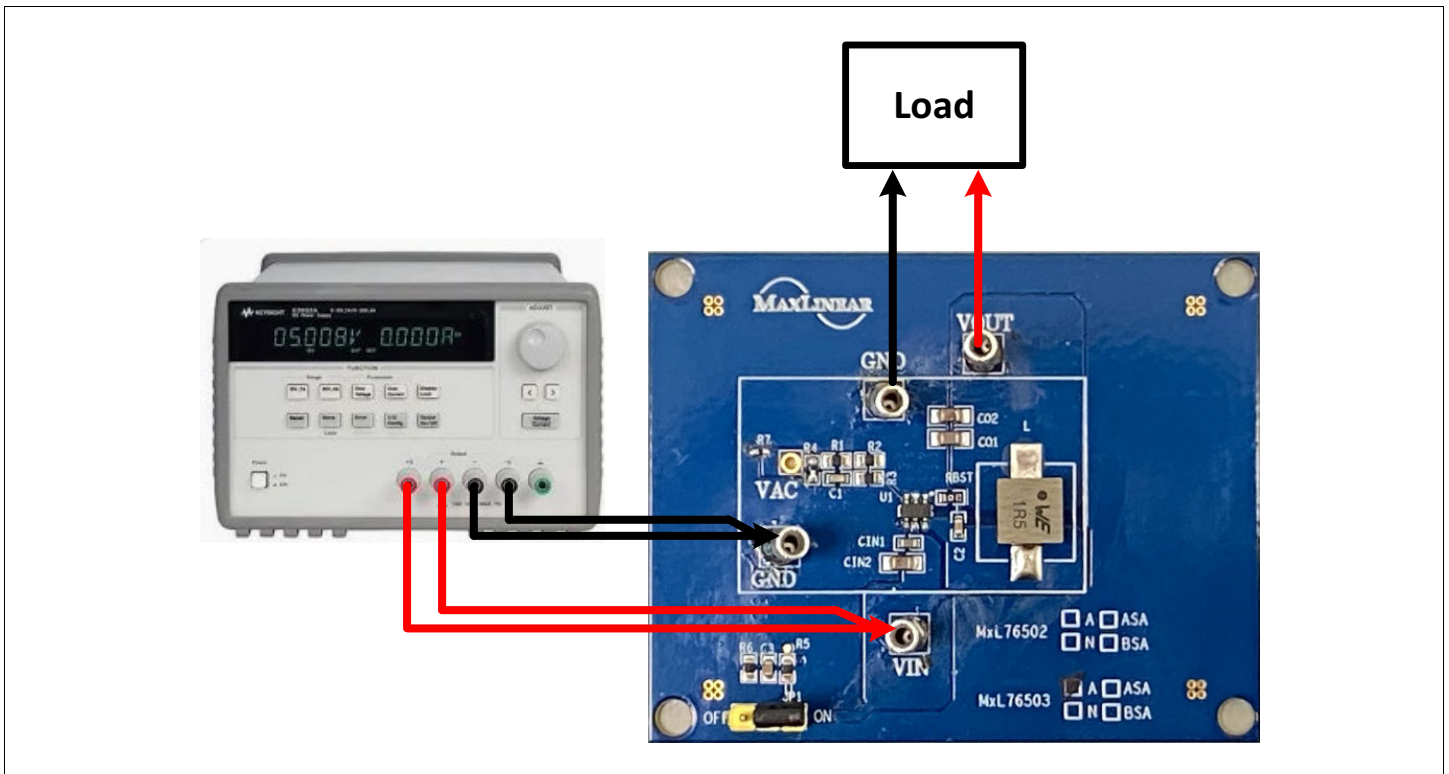

Figure 3: V_{IN} and V_{OUT} Connections of the MxL76503 EVK

Start-Up Procedure

1. Make sure that the pins 2 and 3 of the jumper JP1 are covered by the jumper.
2. Apply the appropriate V_{IN} (typically 12V) to the EVK's VIN and GND pillars.
3. Verify that V_{OUT} is within the output regulation.

Start-Up

The start-up waveform of the MxL76503 is initiated by V_{IN} , as shown in the following figure.

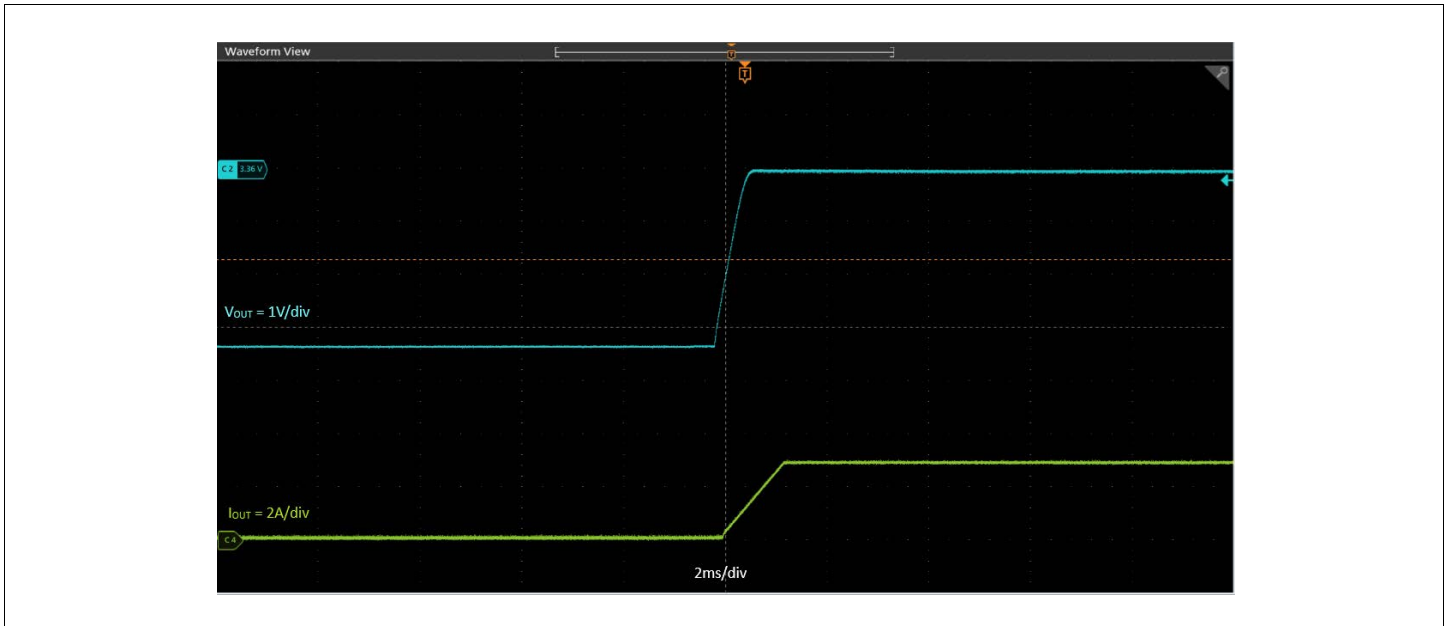

Figure 4: MxL76503 Start-Up with a 3A Load

Shutdown

The shutdown waveform of the MxL76503 is initiated by V_{IN} , as shown in the following figure.

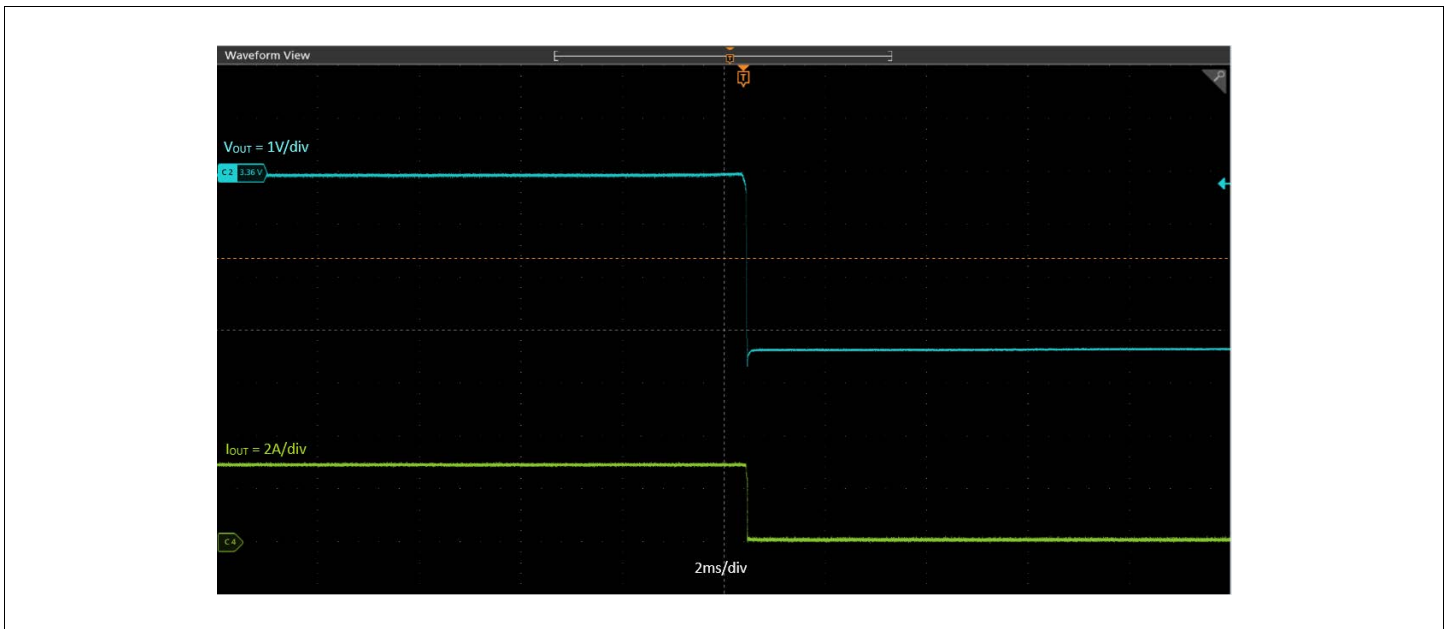

Figure 5: MxL76503 Shutdown with a 3A Load

EVK Schematic

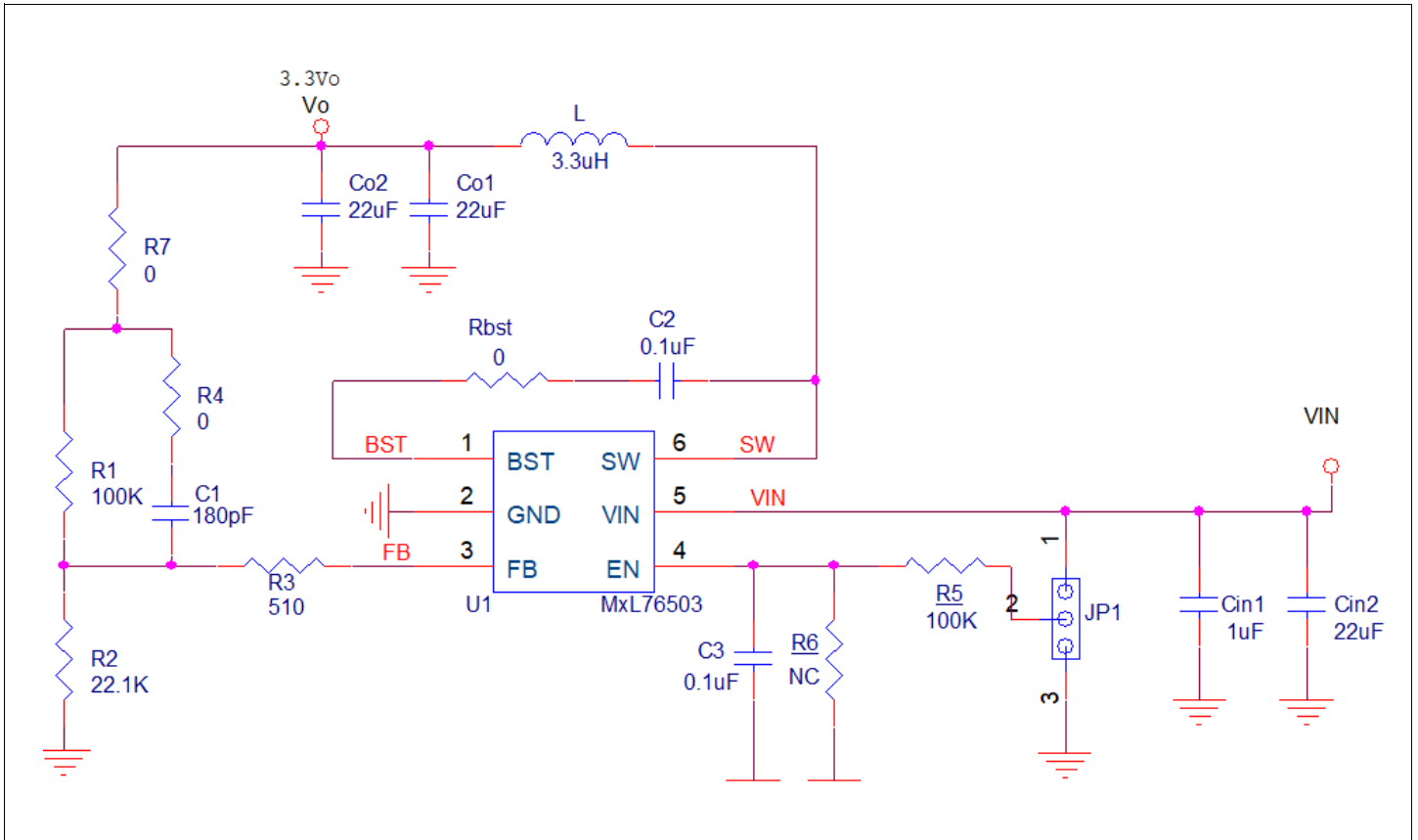

Figure 6: EVK Schematic

EVK PCB Layers

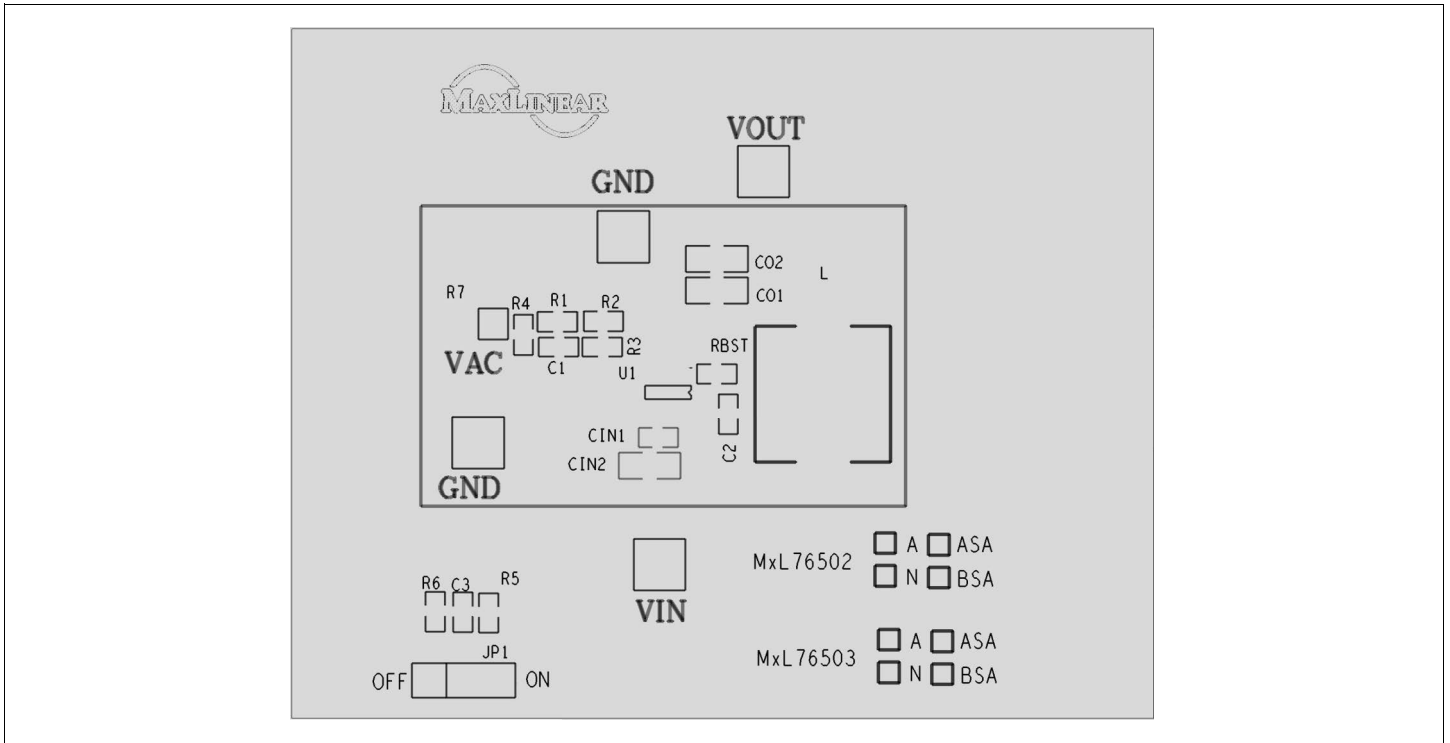

Figure 7: EVK PCB Silkscreen Top

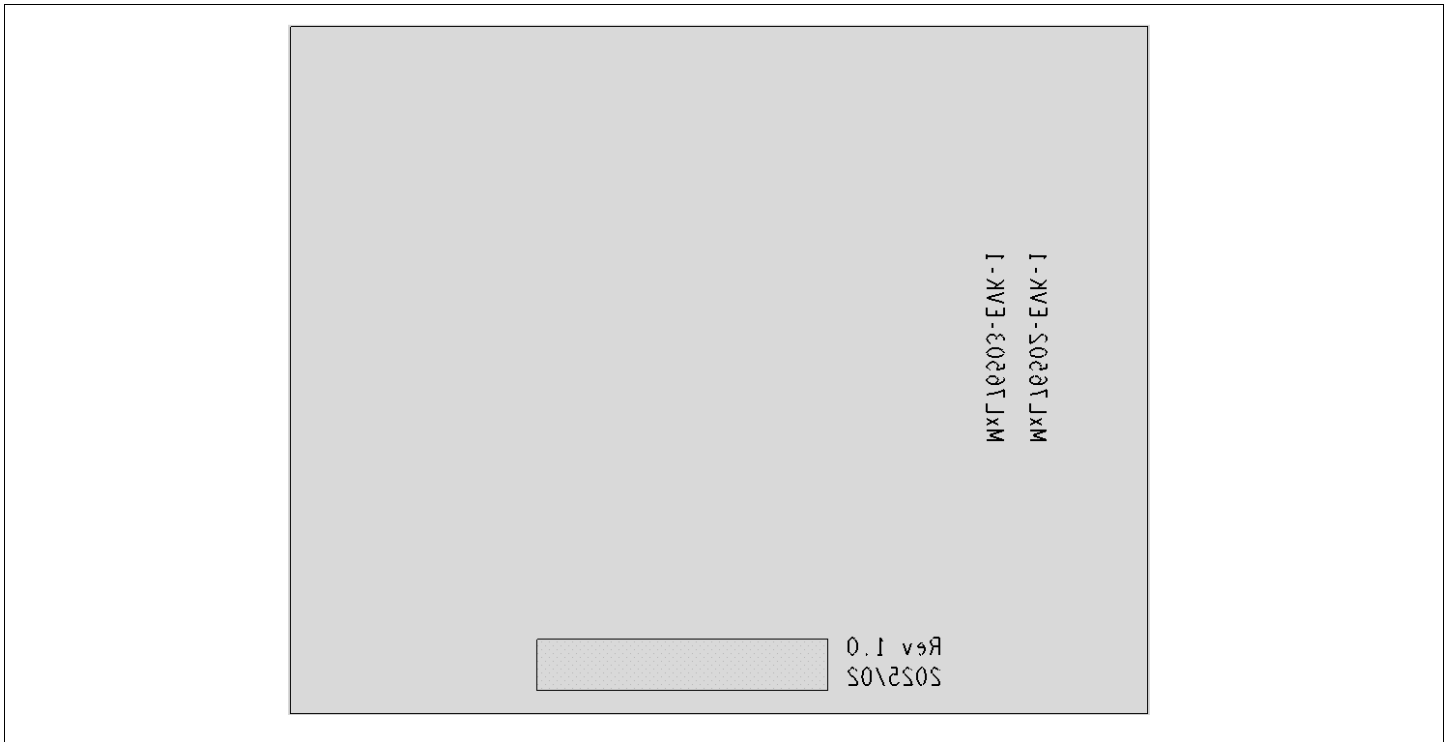

Figure 8: EVK PCB Silkscreen Bottom

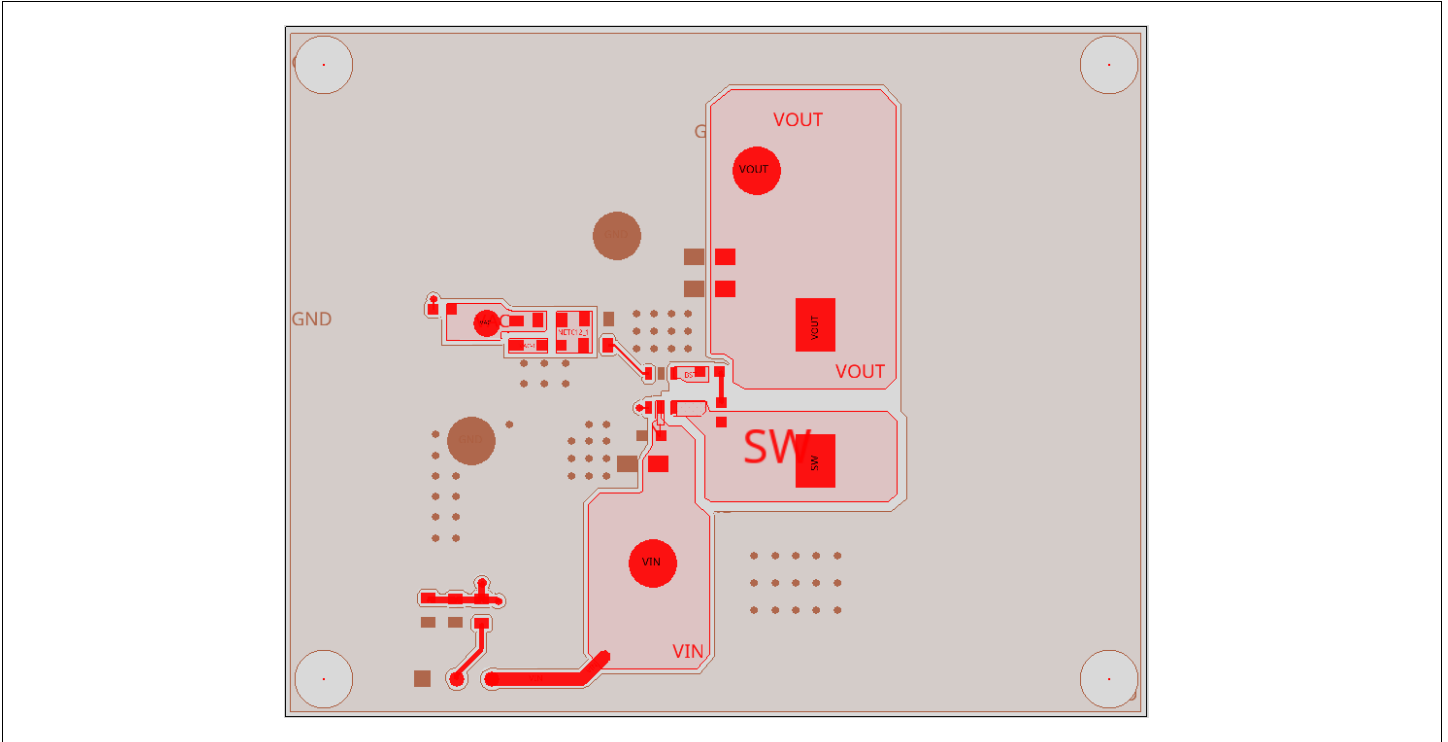

Figure 9: EVK PCB Top Layer

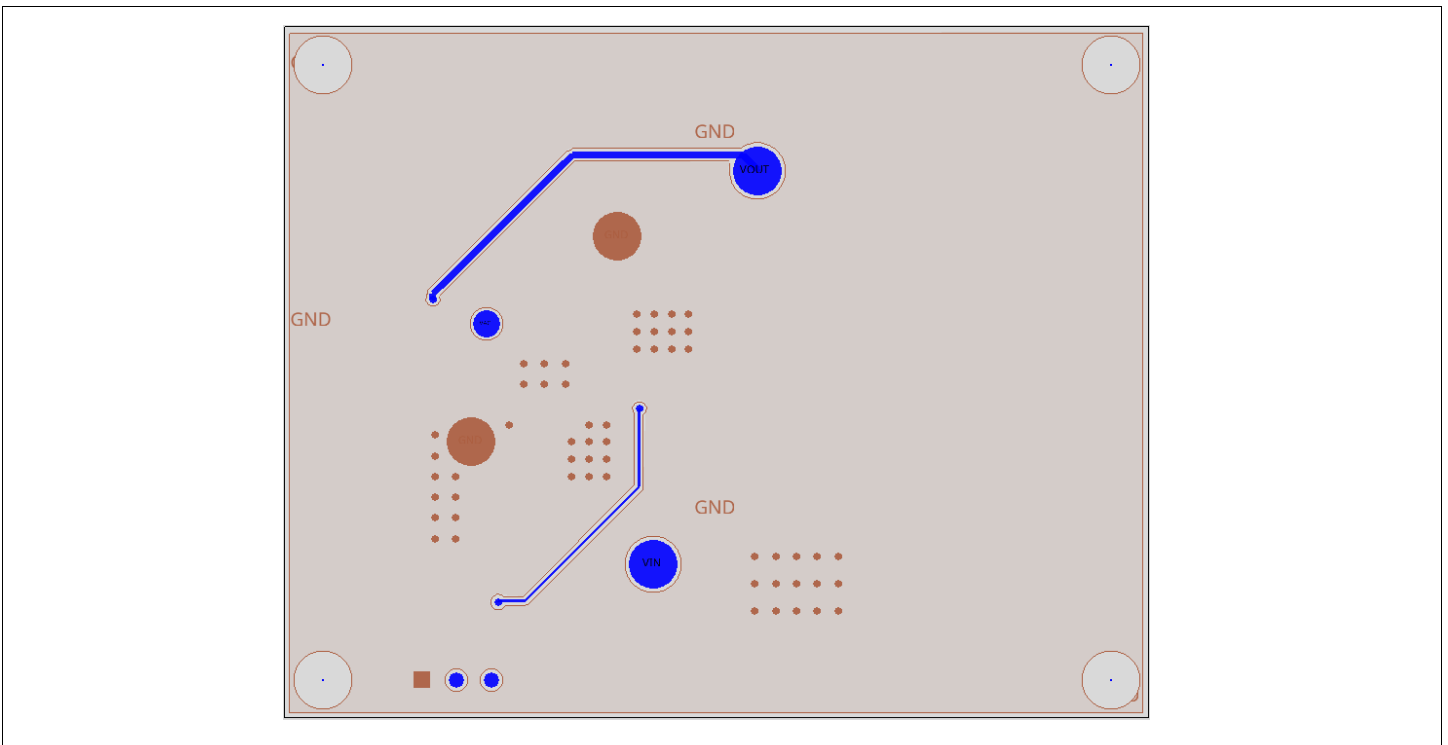

Figure 10: EVK PCB Bottom Layer

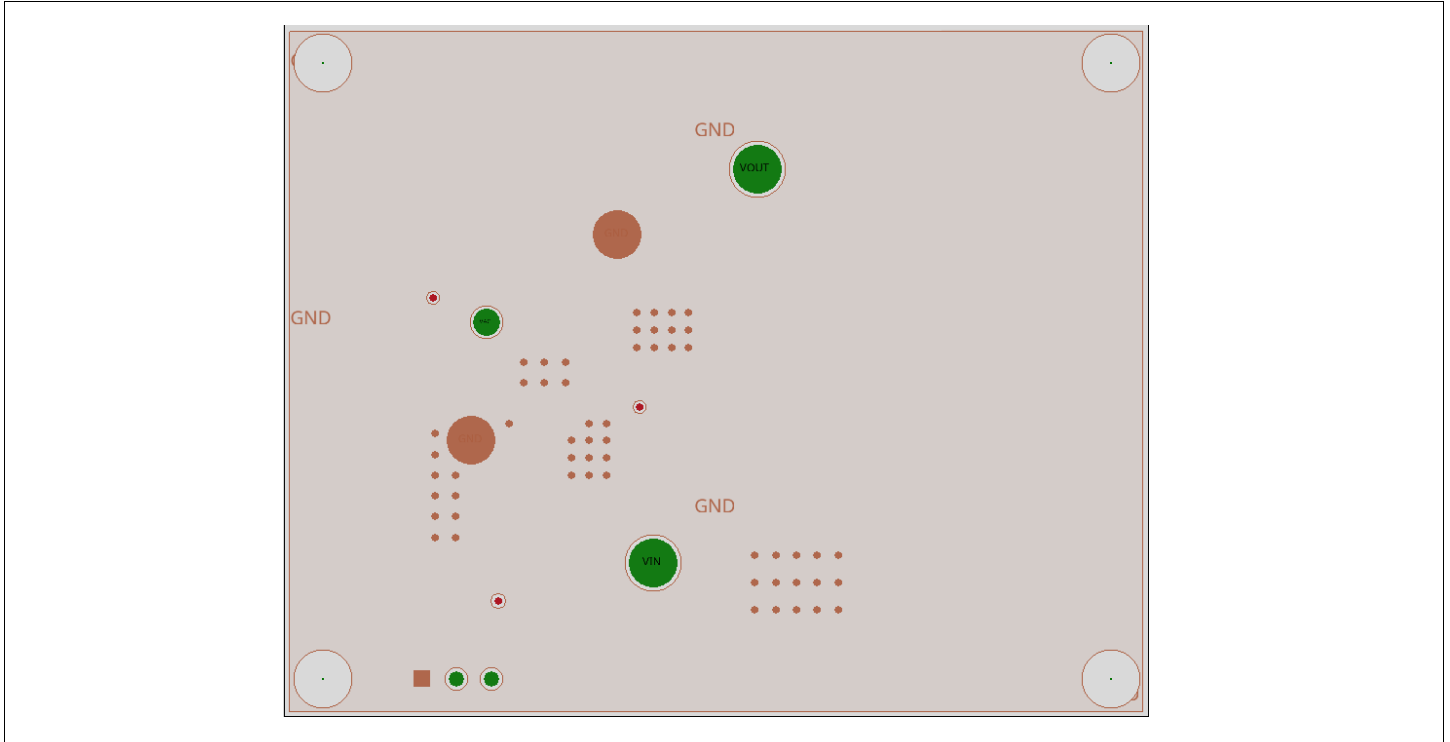

Figure 11: EVK PCB Layer 2

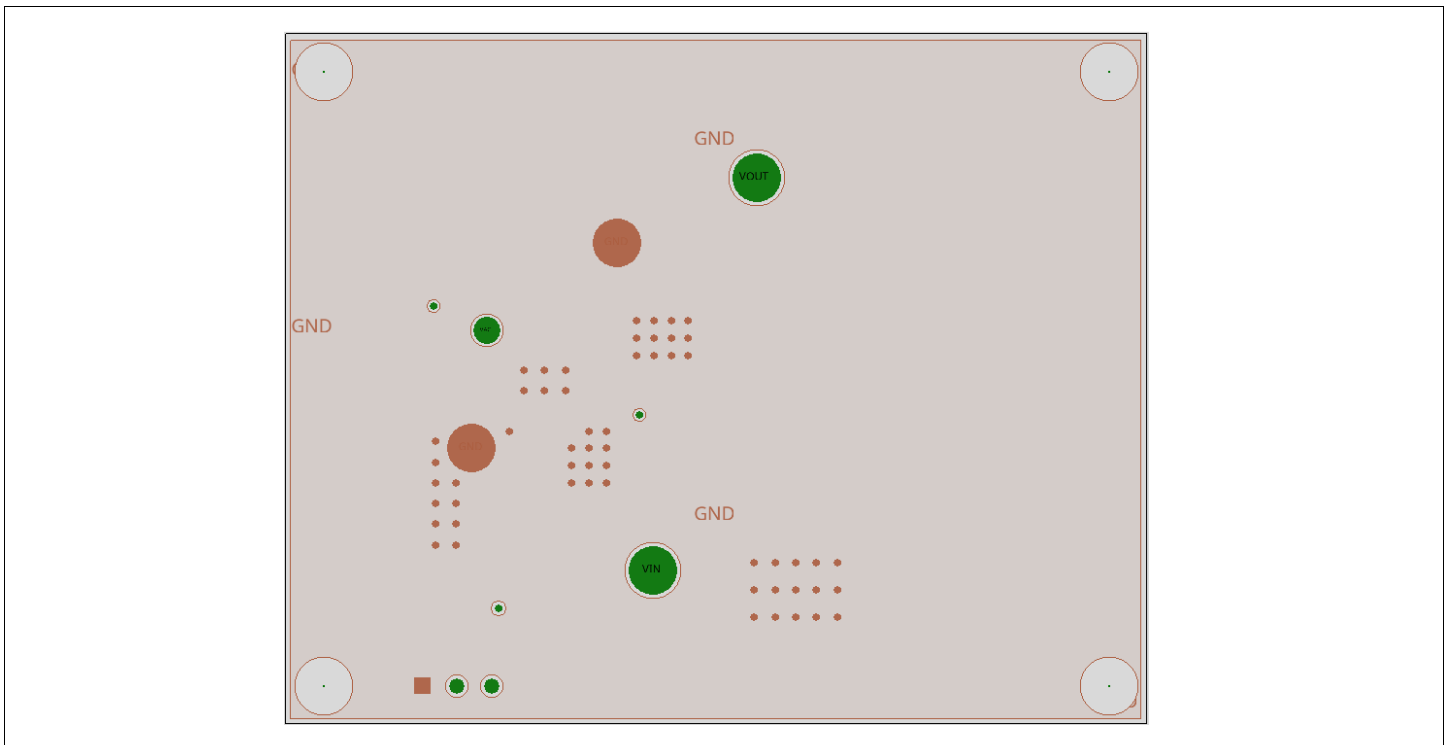

Figure 12: EVK PCB Layer 3

EVK Bill of Materials

Table 5: EVK Bill of Materials

Item	Qty	Reference Designator	Value	Description	Package
1	1	CIN1	1 μ F	Ceramic capacitor, 25V, X5R	0603
2	1	C3	0.1 μ F	Ceramic capacitor, 25V, X5R	0603
3	3	CIN2, CO1, CO2	22 μ F	Ceramic capacitor, 25V, X5R	0805
4	1	C2	100nF	Ceramic capacitor, 10V, X5R	0603
5	1	L	3.3 μ H	Würth 7443845030033	6.65*6.45
6	1	R1	100k Ω	Resistor, \pm 1%	0603
7	1	R2	22.1k Ω	Resistor, \pm 1%	0603
8	1	C1	180pF	Ceramic capacitor, 25V, X5R	0603
9	1	R3	510 Ω	Resistor, \pm 1%	0603
10	1	R5	100k Ω	Resistor, \pm 1%	0603
11	4	VIN, GND, VOUT	-	Pin header	-
12	1	JP1	2.54mm*3	Connector	2.54mm*3
13	1	R6	NC	-	0603
14	1	RBST	0 Ω	Resistor	0603
15	1	Power IC	MXL76503N-ASA-R	Step-down DC/DC converter	SOT23-6L



MaxLinear, Inc.
 5966 La Place Court, Suite 100
 Carlsbad, CA 92008
 Tel.: +1 (760) 692-0711
 Fax: +1 (760) 444-8598
www.maxlinear.com

The content of this document is furnished for informational use only, is subject to change without notice, and should not be construed as a commitment by MaxLinear, Inc. MaxLinear, Inc. assumes no responsibility or liability for any errors or inaccuracies that may appear in the informational content contained in this document. Complying with all applicable copyright laws is the responsibility of the user. Without limiting the rights under copyright, no part of this document may be reproduced into, stored in, or introduced into a retrieval system, or transmitted in any form or by any means (electronic, mechanical, photocopying, recording, or otherwise), or for any purpose, without the express written permission of MaxLinear, Inc.

EXCEPT AS OTHERWISE PROVIDED EXPRESSLY IN WRITING BY MAXLINEAR, AND TO THE MAXIMUM EXTENT PERMITTED BY LAW: (A) THE MAXLINEAR PRODUCTS ARE PROVIDED ON AN "AS IS" BASIS WITHOUT REPRESENTATIONS OR WARRANTIES OF ANY KIND, INCLUDING WITHOUT LIMITATION ANY IMPLIED OR STATUTORY WARRANTIES AND ANY WARRANTIES OF MERCHANTABILITY, FITNESS FOR A PARTICULAR PURPOSE, NON-INFRINGEMENT, OR TITLE; AND (B) MAXLINEAR DOES NOT GUARANTEE THAT THE PRODUCTS WILL BE FREE OF ERRORS OR DEFECTS. MAXLINEAR PRODUCTS SHOULD NOT BE USED IN ANY EMERGENCY, SECURITY, MILITARY, LIFE-SAVING, OR OTHER CRITICAL USE CASE WHERE A FAILURE OR MALFUNCTION COULD CAUSE PERSONAL INJURY OR DEATH, OR DAMAGE TO OR LOSS OF PROPERTY. USERS ASSUME ALL RISK FOR USING THE MAXLINEAR PRODUCTS IN SUCH USE CASE. CUSTOMERS AND USERS ARE SOLELY RESPONSIBLE FOR USING THEIR OWN SKILL AND JUDGMENT TO DETERMINE WHETHER MAXLINEAR PRODUCTS ARE SUITABLE FOR THE INTENDED USE CASE.

MaxLinear, Inc. may have patents, patent applications, trademarks, copyrights, or other intellectual property rights covering subject matter in this document. Except as expressly provided in any written license agreement from MaxLinear, Inc., the furnishing of this document does not give you any license to these patents, trademarks, copyrights, or other intellectual property.

MaxLinear, the MaxLinear logo, and any other MaxLinear trademarks (including but not limited to MxL, Full-Spectrum Capture, FSC, AirPHY, Puma, AnyWAN, VectorBoost, MXL WARE, and Panther) are all property of MaxLinear, Inc. or one of MaxLinear's subsidiaries in the U.S.A. and other countries. All rights reserved.

All third-party marks and logos are trademarks™ or registered® trademarks of their respective holders/owners. Use of such marks does not imply any affiliation with, sponsorship or endorsement by the owners/holders of such trademarks. All references by MaxLinear to third party trademarks are intended to constitute nominative fair use under applicable trademark laws.

The URLs provided are for informational purposes only; they do not constitute an endorsement or an approval by MaxLinear of any of the products or services of the corporation or organization or individual. MaxLinear bears no responsibility for the accuracy, legality or content of the external site or for that of subsequent links. Contact the external site for answers to questions regarding its content.