



MxL82200 and MxL82210

8-bit I²C/SMBUS GPIO Expander Preliminary Data Sheet

General Description

The MxL82200 and MxL82210 are 8-bit GPIO expanders with an I²C/SMBus interface. After power-up, the MxL82200 has internal 100K ohm pull-up resistors on each I/O pin that can be individually enabled. The MxL82210 has internal pull-up resistors enabled upon power-up in case it is necessary for the inputs to be in a known state.

In addition, the GPIOs on the MxL82200 and MxL82210 can individually be controlled and configured. As outputs, the GPIOs can be outputs that are high, low, or in three-state mode. The three-state mode feature is useful for applications where the power is removed from the remote devices, but they may still be connected to the GPIO expander.

As inputs, the internal pull-up resistors can be enabled or disabled and the input polarity can be inverted. The interrupt behavior is configurable. It can be set to trigger on a rising edge, falling edge, or both edges. The interrupt condition is cleared either when the input returns to its original state or when the current input state is read.

The MxL82200 and MxL82210 are enhanced versions of other 8-bit GPIO expanders with an I²C/SMBus interface. The MxL82200 is pin and software compatible with the CAT9534 and PCA9534. The MxL82210 is pin and software compatible with the CAT9554 and PCA9554. The MxL82200 and MxL82210 are also pin compatible with the PCA9554A and TCA9554A.

The MxL82200 and MxL82210 are available in 16-pin TSSOP and 16-pin QFN packages.

Applications

- Personal digital assistants (PDA)
- Cellular phones/data devices
- Battery-operated devices
- Global Positioning System (GPS)
- Bluetooth

Features

- 1.62V to 5.5V operating voltage
- 8 General Purpose I/Os (GPIOs)
- Maximum stand-by current of 1uA at +1.8V
- I²C/SMBus bus interface
- I²C clock frequency up to 1MHz
- Noise filter on SDA and SCL inputs
- Up to 32 I²C Slave Addresses
- Individually programmable inputs
- Internal pull-up resistors
- Polarity inversion
- Individual interrupt enable
- Rising edge and/or falling edge interrupt
- Input filter
- Individually programmable outputs
- Output level control
- Output three-state control
- Open-drain active low interrupt output
- Pin and software compatible with CAT9534, CAT9554, PCA9534, and PCA9554
- 3kV HBM ESD protection per *JESD22-A114F*
- 200mA latch-up performance per *JESD78B*

Revision History

Document No.	Release Date	Change Description
302DSR00	May 19, 2026	Initial preliminary release.

Table of Contents

General Description	i
Applications	i
Features	i
Specifications	1
Absolute Maximum Ratings	1
Electrical Characteristics	2
DC Electrical Characteristics	2
AC Electrical Characteristics	3
Pin Configuration	5
Pin Description	5
Block Diagram	6
Functional Description	7
I2C-Bus Interface	7
I2C-Bus Addressing	8
I2C Read and Write	9
I2C Command Byte	9
Interrupts	10
Register Description	11
GPIO State Register (GSR)—Read-Only	11
Output Control Register (OCR)—Read/Write	11
Input Polarity Inversion Register (PIR)—Read/Write	11
GPIO Configuration Register (GCR)—Read/Write	11
Input Internal Pull-up Enable/Disable Register (PUR)—Read/Write	11
Input Interrupt Enable Register (IER)—Read/Write	11
Output Three-State Control Register (TSCR)—Read/Write	11
Input Interrupt Status Register (ISR)—Read-Only	12
Input Rising Edge Interrupt Enable Register (REIR)—Read/Write	12
Input Falling Edge Interrupt Enable Register (FEIR)—Read/Write	12
Input Filter Enable Register (IFR)—Read/Write	12
Mechanical Dimensions	13
16-Pin QFN	13
16-Pin TSSOP	14
Ordering Information	15

List of Figures

Figure 1: I2C-Bus Timing Diagram	3
Figure 2: Write To Output	4
Figure 3: GPIO Pin Interrupt	4
Figure 2: Pin Configuration (Top View)	5
Figure 3: Functional Block Diagram	6
Figure 4: I ² C Start and Stop Conditions	7
Figure 5: Master Writes To Slave	7
Figure 6: Master Reads From Slave	7
Figure 7: QFN-16 Mechanical Dimensions	13
Figure 8: TSSOP-16 Mechanical Dimensions	14

List of Tables

Table 1: Absolute Maximum Ratings.....	1
Table 2: DC Electrical Characteristics.....	2
Table 3: AC Electrical Characteristics.....	3
Table 4: Pin Description.....	5
Table 5: I2C Address Map.....	8
Table 6: I2C Command Byte (Register Address).....	9
Table 7: Interrupt Generation and Clearing.....	10
Table 8: Ordering Information.....	15

Specifications

Absolute Maximum Ratings

Important: The stresses above what is listed under the following table may cause permanent damage to the device. This is a stress rating only—functional operation of the device above what is listed under the following table or any other conditions beyond what MaxLinear recommends is not implied. Exposure to conditions above the recommended extended periods of time may affect device reliability. Solder reflow profile is specified in the *IPC/JEDEC J-STD-020C* standard.

Table 1: Absolute Maximum Ratings

Parameter	Minimum	Maximum	Unit
Power Supply Voltage	-	6	V
Supply Current	-	160	mA
Ground Current	-	200	mA
External Current limit of each GPIO	-	25	mA
Total Current limit for GPIO[7:0]	-	100	mA
Total Supply Current sourced by all GPIOs	-	160	mA
Operating Temperature	-40	+85	°C
Storage Temperature	-65	+150	°C
Power Dissipation	-	200	mW

Electrical Characteristics

DC Electrical Characteristics

Unless otherwise noted, $T_A = -40^\circ$ to $+85^\circ\text{C}$, V_{CC} is from 1.62V to 5.5V.

Table 2: DC Electrical Characteristics

Symbol	Parameter	Limits $1.8V \pm 10\%$		Limits $2.5V \pm 10\%$		Limits $3.3V \pm 10\%$		Limits $5V \pm 10\%$		Units	Conditions
		Min	Max	Min	Max	Min	Max	Min	Max		
V_{IL}	Input Low Voltage	-0.3	0.3VCC	-0.3	0.3VCC	-0.3	0.3VCC	-0.3	0.3×VCC	V	Note 1
V_{IL}	Input Low Voltage	-0.3	0.2	-0.3	0.5	-0.3	0.8	-0.3	1.1	V	Note 2
V_{IH}	Input High Voltage	1.3	VCC	1.8	VCC	2.3	VCC	0.7×VCC	VCC	V	Note 1
V_{IH}	Input High Voltage	1.4	5.5	1.8	5.5	2.0	5.5	2.3	5.5	V	Note 2
V_{OL}	Output Low Voltage	0	0.4	0	0.4	0	0.4	0	0.4	V	$I_{OL} = 3\text{mA}$ Note 3
V_{OL}	Output Low Voltage	0	0.5	0	0.5	0	0.5	0	0.5	V	$I_{OL} = 8\text{mA}$ Note 4
V_{OL}	Output Low Voltage	0	0.4	0	0.4	0	0.4	0	0.4	V	$I_{OL} = 1.5\text{mA}$ $I_{OL} = 4\text{mA}$ $I_{OL} = 6\text{mA}$ Note 5
V_{OH}	Output High Voltage	1.2	-	1.8	-	2.6	-	4.1	-	V	$I_{OH} = -8\text{mA}$ Note 4
I_{IL}	Input Low Leakage Current	-	±10	-	±10	-	±10	-	±10	μA	-
I_{IH}	Input High Leakage Current	-	±10	-	±10	-	±10	-	±10	μA	-
I_{CC}	Power Supply Current	-	50	-	100	-	200	-	400	μA	Note 6
I_{CC}	Power Supply Current	-	150	-	250	-	500	-	1000	μA	Note 7
I_{CCS}	Standby Current	-	1	-	2	-	5	-	7	μA	Note 8
C_{IN}	Input Pin Capacitance	-	5	-	5	-	5	-	5	pF	-
R_{GPIO}	GPIO pull-up Resistance	60	140	60	140	60	140	60	140	kΩ	100kΩ ±40%
$R_{RESET\#}$	Pull-up Resistance	35	85	35	85	35	85	35	85	KΩ	60kΩ ±40%

1. For I²C input signals (SDA, SCL).

2. For GPIOs, A0, A1, and A2 signals.

3. For I²C output signal SDA.

4. For GPIOs.

5. For IRQ# signal

6. Test 1: SCL frequency is 1MHz with internal pull-ups disabled. All GPIOs are configured as inputs. All inputs are steady at VCC or GND. Outputs are floating or in the tri-state mode.

7. Test 2: SCL frequency is 1MHz with internal pull-ups enabled. All GPIOs are configured as inputs. All inputs are steady at VCC or GND. Outputs are floating or in the tri-state mode.

8. Test 3: All inputs are steady at VCC or GND to minimize standby current. If internal pull-up is enabled, input voltage level should be the same as VCC. All GPIOs are configured as inputs. SCL and SDA are at VCC. Outputs are left floating or in tri-state mode.

AC Electrical Characteristics

Unless otherwise noted, $T_A = -40^\circ$ to $+85^\circ\text{C}$, V_{CC} is from 1.62V to 5.5V.

Table 3: AC Electrical Characteristics

Symbol	Parameter	Standard Mode I ² C-Bus		Fast Mode I ² C-Bus		Fast Mode Plus I ² C-Bus		Unit
		Min	Max	Min	Max	Min	Max	
f_{SCL}	Operating Frequency	0	100	0	400	0	1000	kHz
T_{BUF}	Bus Free Time between STOP and START	4.7	-	1.3	-	0.5	-	μs
$T_{HD;STA}$	START Condition Hold Time	4.7	-	0.6	-	0.26	-	μs
$T_{SU;STA}$	START Condition Setup Time	4.7	-	0.6	-	0.26	-	μs
$T_{HD;DAT}$	Data Hold Time	0	-	0	-	0	-	ns
$T_{VD;ACK}$	Data Valid Acknowledge	-	3.45	-	0.9	-	0.45	μs
$T_{VD;DAT}$	SCL LOW to Data Out Valid	-	3.45	-	0.9	-	0.45	μs
$T_{SU;DAT}$	Data Setup time	250	-	150	-	50	-	ns
T_{LOW}	Clock LOW Period	4.7	-	1.3	-	0.5	-	μs
T_{HIGH}	Clock HIGH Period	4.0	-	0.6	-	0.26	-	μs
T_F	Clock/Data Fall Time	-	300	-	300	-	120	ns
T_R	Clock/Data Rise Time	-	1000	-	300	-	120	ns
T_{SP}	Pulse width of Spikes Tolerance	-	50	-	50	-	50	ns
T_{D1}	I ² C-bus GPIO Output Valid	-	0.2	-	0.2	-	0.2	μs
T_{D4}	I ² C Input Pin Interrupt Valid	-	4	-	4	-	4	μs
T_{D5}	I ² C Input Pin Interrupt Clear	-	4	-	4	-	4	μs
T_{D15}	SCL Delay after Reset	3	-	3	-	3	-	μs

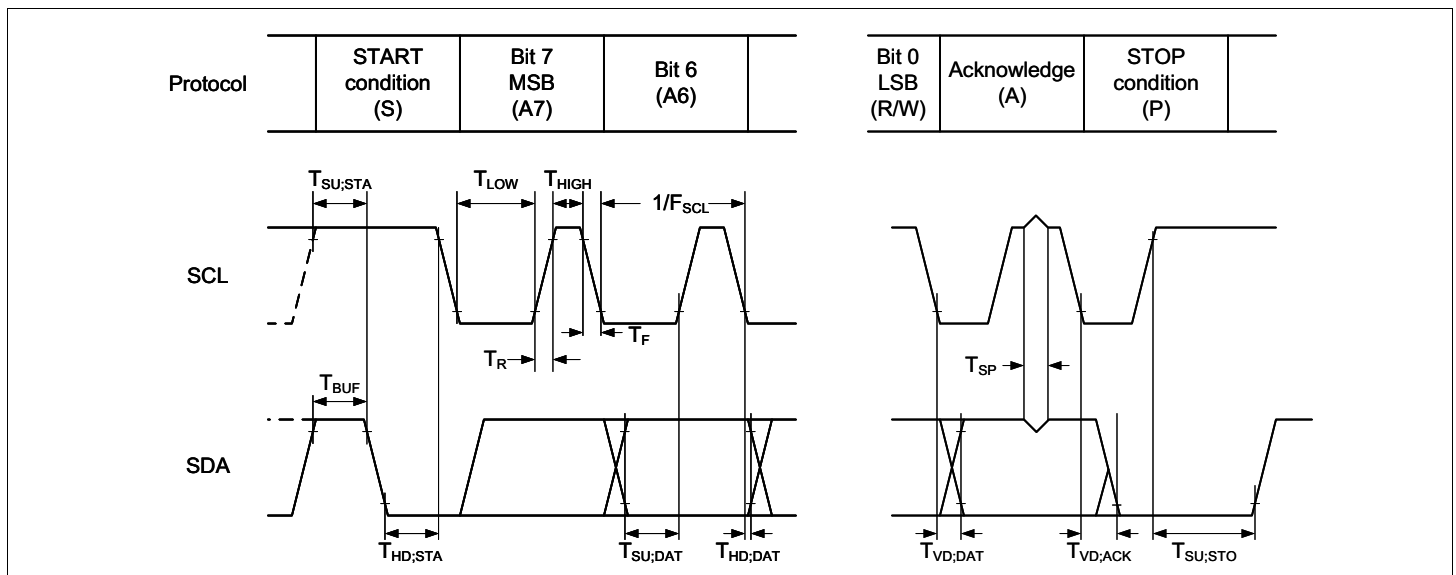

Figure 1: I²C-Bus Timing Diagram

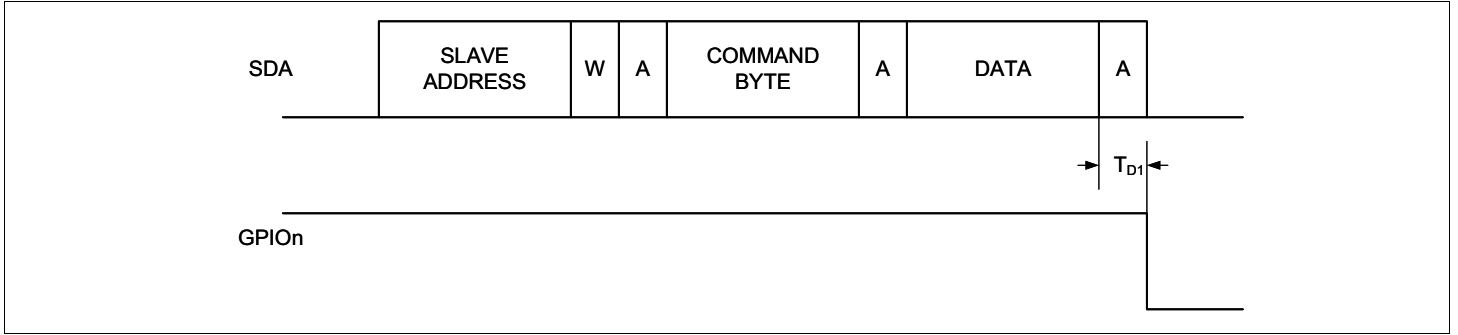

Figure 2: Write To Output

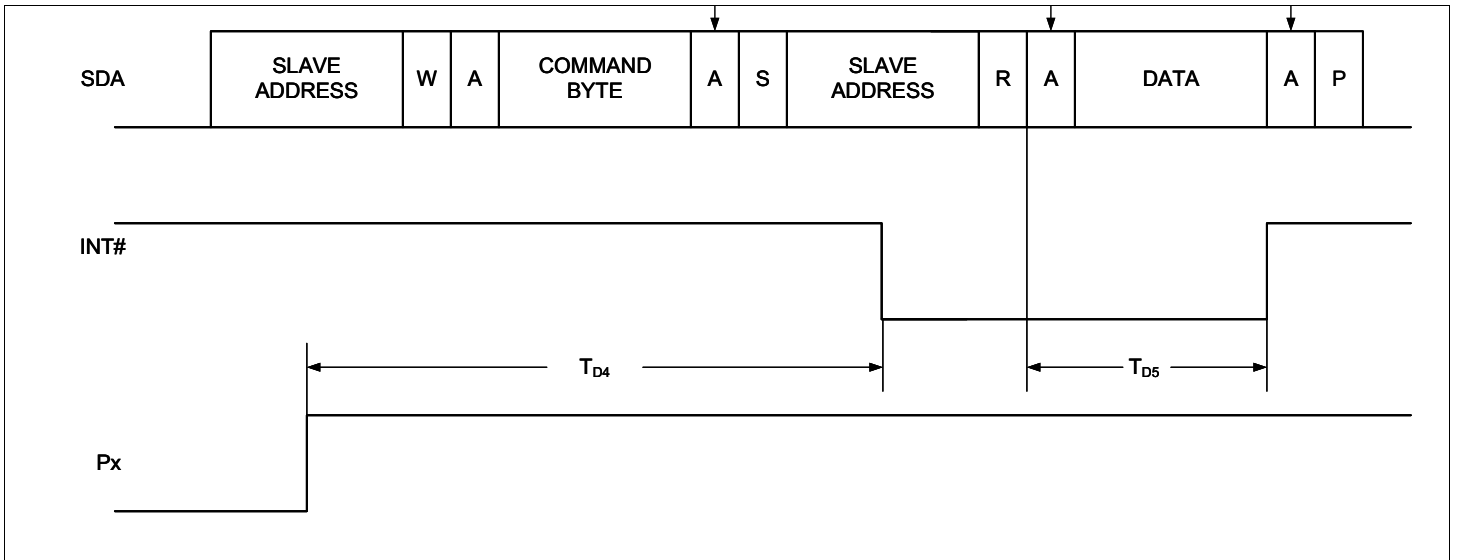

Figure 3: GPIO Pin Interrupt

Pin Configuration

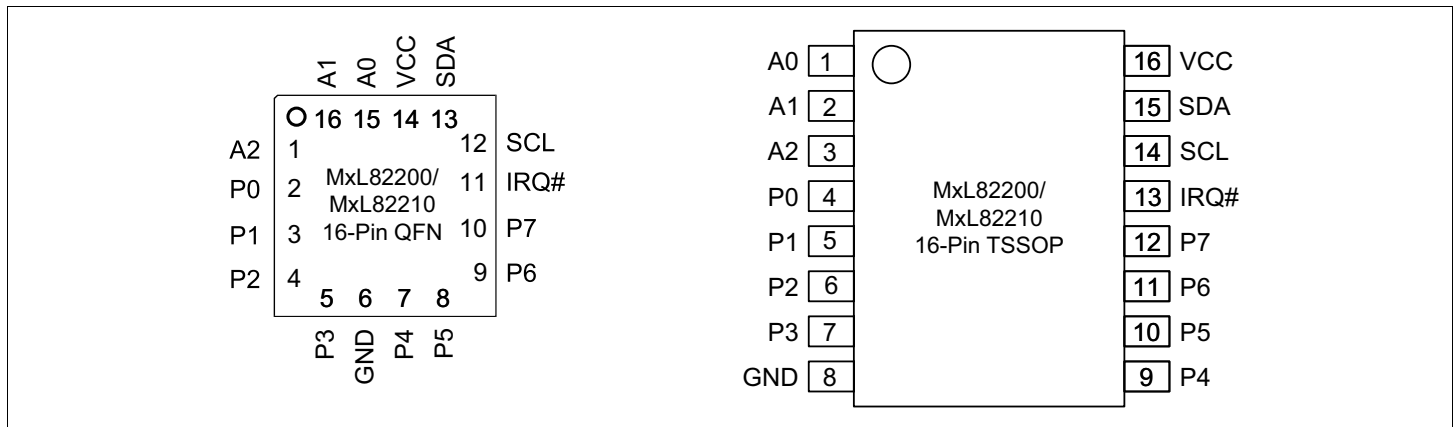

Figure 2: Pin Configuration (Top View)

Pin Description

Table 4: Pin Description

Name	QFN-16 Pin#	TSSOP-16 Pin#	Type	Description
I²C Interface				
SDA	13	15	I/O	I ² C-bus data input/output (open-drain).
SCL	12	14	I	I ² C-bus serial input clock.
IRQ#	11	13	OD	Interrupt output (open-drain, active LOW).
A0	15	1	I	These pins select the I ² C slave address. See Table 5 on page 8.
A1	16	2	I	
A2	1	3	I	
GPIOs				
P0	2	4	I/O	General purpose I/Os P0-P7. All GPIOs are configured as inputs upon power-up or after a reset. After power-up or reset, the internal pull-up resistors are enabled.
P1	3	5	I/O	
P2	4	6	I/O	
P3	5	7	I/O	
P4	7	9	I/O	
P5	8	10	I/O	
P6	9	11	I/O	
P7	10	12	I/O	
Ancillary Signals				
VCC	14	16	Pwr	1.62V to 5.5V VCC supply voltage.
GND	6	8	Pwr	Power supply common, ground.
GND	Center Pad	-	Pwr	The exposed pad at the bottom surface of the package is designed for thermal performance. Use of a center pad on the PCB is strongly recommended for thermal conductivity as well as to provide mechanical stability of the package on the PCB. The center pad is recommended to be solder masked defined with opening size less than or equal to the exposed thermal pad on the package bottom to prevent solder bridging to the outer leads of the device. Thermal vias must be connected to GND plane as the thermal pad of package is at GND potential.

Note: Pin type: I = Input, O = Output, I/O = Input/Output, OD = Output Open Drain.

Block Diagram

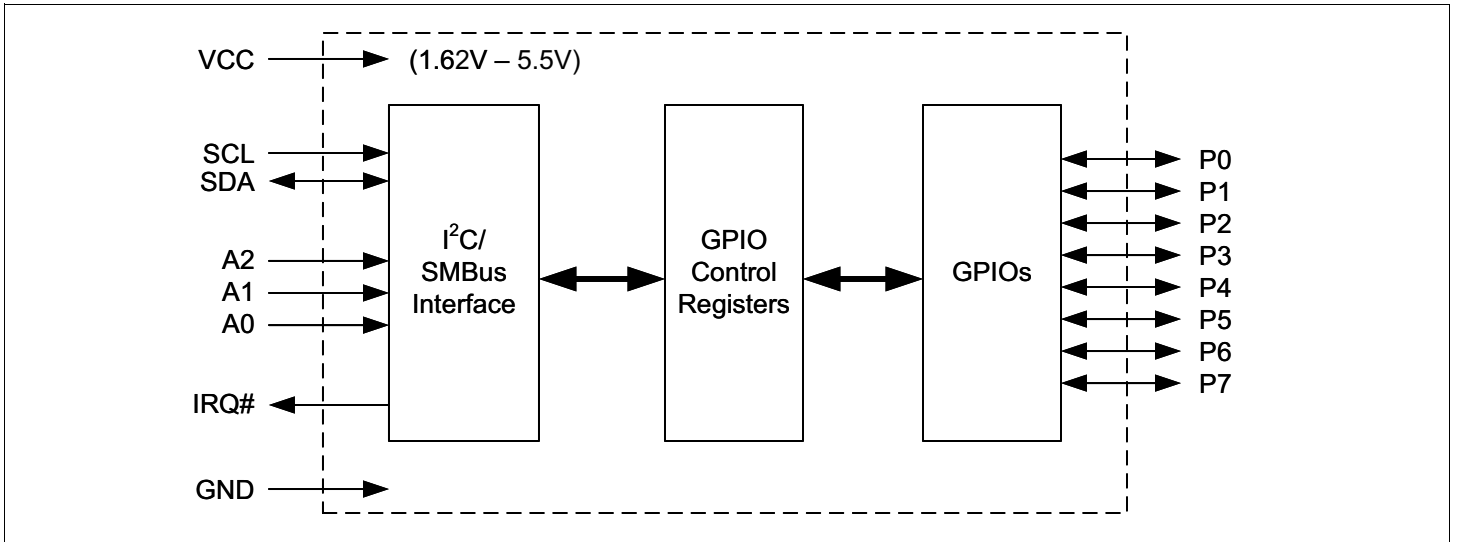

Figure 3: Functional Block Diagram

Functional Description

I²C-Bus Interface

The I²C-bus interface is compliant with the standard-mode and fast-mode I²C-bus specifications. The I²C-bus interface consists of two lines: serial data (SDA) and serial clock (SCL). In the standard-mode, the serial clock and serial data can go up to 100kbps, in the fast-mode, the serial clock and serial data can go up to 400kbps, and the fast-mode plus can go up to 1MHz bps.

The first byte sent by an I²C-bus master contains a start bit (SDA transition from HIGH to LOW when SCL is HIGH), 7-bit slave address and whether it is a read or write transaction. The next byte is the sub-address that contains the address of the register to access. The MxL82200 and MxL82210 respond to each write with an acknowledge (SDA driven LOW by the MxL82200 and MxL82210 devices for one clock cycle when SCL is HIGH). The last byte sent by an I²C-bus master contains a stop bit (SDA transition from LOW to HIGH when SCL is HIGH). See Figure 4, Figure 5, and Figure 6. For complete details, see the I²C-bus specifications.

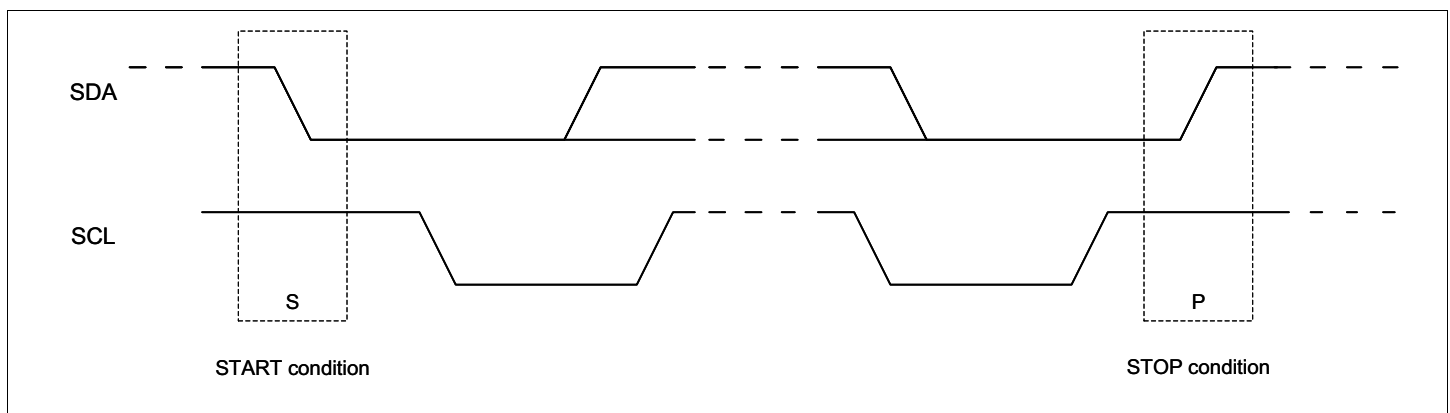

Figure 4: I²C Start and Stop Conditions

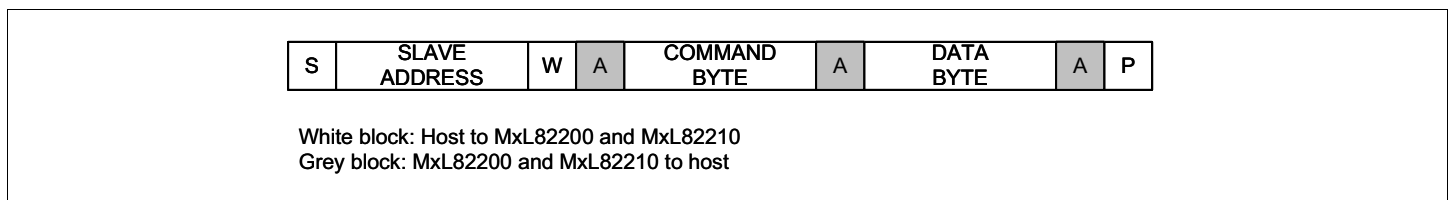

Figure 5: Master Writes To Slave

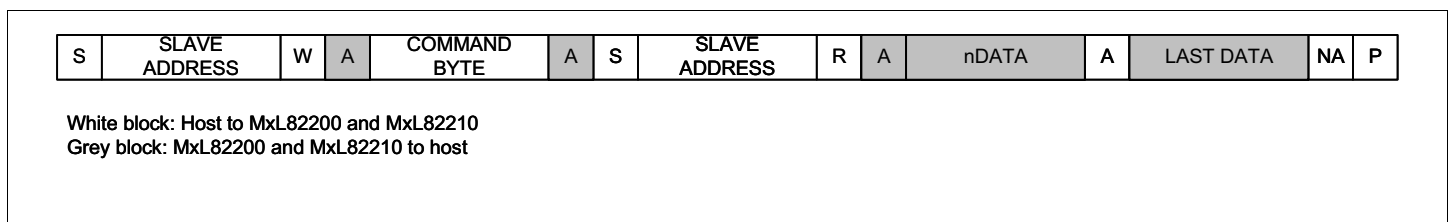

Figure 6: Master Reads From Slave

I²C-Bus Addressing

There can be many devices on the I²C-bus. To distinguish itself from the other devices on the I²C-bus, the MxL82200 and MxL82210 have up to 32 I²C slave addresses using the A2-A0 address lines. The following table lists the different addresses that can be selected.

Table 5: I²C Address Map

A2	A1	A0	I ² C Address
GND	SCL	GND	0x20 (0010 000X)
GND	SCL	VCC	0x22 (0010 001X)
GND	SDA	GND	0x24 (0010 010X)
GND	SDA	VCC	0x26 (0010 011X)
VCC	SCL	GND	0x28 (0010 100X)
VCC	SCL	VCC	0x2A (0010 101X)
VCC	SDA	GND	0x2C (0010 110X)
VCC	SDA	VCC	0x2E (0010 111X)
GND	SCL	SCL	0x30 (0011 000X)
GND	SCL	SDA	0x32 (0011 001X)
GND	SDA	SCL	0x34 (0011 010X)
GND	SDA	SDA	0x36 (0011 011X)
VCC	SCL	SCL	0x38 (0011 100X)
VCC	SCL	SDA	0x3A (0011 101X)
VCC	SDA	SCL	0x3C (0011 110X)
VCC	SDA	SDA	0x3E (0011 111X)
GND	GND	GND	0x40 (0100 000X)
GND	GND	VCC	0x42 (0100 001X)
GND	VCC	GND	0x44 (0100 010X)
GND	VCC	VCC	0x46 (0100 011X)
VCC	GND	GND	0x48 (0100 100X)
VCC	GND	VCC	0x4A (0100 101X)
VCC	VCC	GND	0x4C (0100 110X)
VCC	VCC	VCC	0x4E (0100 111X)
GND	GND	SCL	0x50 (0101 000X)
GND	GND	SDA	0x52 (0101 001X)
GND	VCC	SCL	0x54 (0101 010X)
GND	VCC	SDA	0x56 (0101 011X)
VCC	GND	SCL	0x58 (0101 100X)
VCC	GND	SDA	0x5A (0101 101X)
VCC	VCC	SCL	0x5C (0101 110X)
VCC	VCC	SDA	0x5E (0101 111X)

I²C Read and Write

A read or write transaction is determined by bit-0 of the slave address. If bit-0 is '0', then it is a write transaction. If bit-0 is '1', then it is a read transaction.

I²C Command Byte

An I²C command byte is sent by the I²C master following the slave address. The command byte indicates the address offset of the register that is accessed. The following table lists the command bytes for each register.

Table 6: I²C Command Byte (Register Address)

Command Byte	Register Name Description	Read/Write	Default Values
0x00	GSR–GPIO State	Read-Only	0xXX
0x01	OCR–Output Control	Read/Write	0xFF
0x02	PIR–Input Polarity Inversion	Read/Write	0x00
0x03	GCR–GPIO Configuration	Read/Write	0xFF
0x04	PUR–Input Internal Pull-up Resistor Enable/Disable	Read/Write	0x00 (MxL8200) 0xFF (MxL82210)
0x05	IER–Input Interrupt Enable	Read/Write	0x00
0x06	TSCR–Output Three-State Control	Read/Write	0x00
0x07	ISR–Input Interrupt Status	Read	0x00
0x08	REIR–Input Rising Edge Interrupt Enable	Read/Write	0x00
0x09	FEIR–Input Falling Edge Interrupt Enable	Read/Write	0x00
0x0A	IFR–Input Filter Enable/Disable	Read/Write	0xFF

Interrupts

The following table lists the interrupt behavior of the different register settings for the MxL82200 and MxL82210 devices.

Table 7: Interrupt Generation and Clearing

GCR Bit	IER Bit	REIR Bit	FEIR Bit	IFR Bit	Interrupt Generated By:	Interrupt Cleared By:
1	0	X	X	X	No interrupts enabled (default).	N/A
1	1	0	0	0	A rising or falling edge on the input.	Reading the GSR register or if the input changes back to its previous state (state of input during last read to GSR)
				1	A rising or falling edge on the input and remains in the new state for more than 1075ns.	
1	1	1	0	0	A rising edge on the input.	Reading the GSR register
				1	A rising edge on the input and remains high for more than 1075ns.	
1	1	0	1	0	A falling edge on the input.	Reading the GSR register
				1	A falling edge on the input and remains low for more than 1075ns.	
1	1	1	1	0	A rising or falling edge on the input.	Reading the GSR register
				1	A rising or falling edge on the input and remains in the new state for more than 1075ns.	
0	x	x	x	x	No interrupts in output mode.	N/A

Register Description

GPIO State Register (GSR)—Read-Only

The status of P7 - P0 can be read via this register. A read shows the current state of these pins (or the inverted state of these pins if enabled via the PIR Register). Reading this register clears an input interrupt (for complete details, see [Table 7](#) on page 10). Reading this register also returns the last value written to the OCR register for any pins that are configured as outputs (that is, this is not the same as the state of the actual output pin since the output pin can be in three-state mode). A write to this register has no effect. The MSB of this register corresponds with P7 and the LSB of this register corresponds with P0.

Output Control Register (OCR)—Read/Write

When P7 - P0 are defined as outputs, they can be controlled by writing to this register. Reading this register returns the last value written to it, however, this value may not be the actual state of the output pin since these pins can be in three-state mode. The MSB of this register corresponds with P7 and the LSB of this register corresponds with P0.

Input Polarity Inversion Register (PIR)—Read/Write

When P7 - P0 are defined as inputs, this register inverts the polarity of the input value read from the Input Port Register. If the corresponding bit in this register is set to '1', the value of this bit in the GSR Register is the inverted value of the input pin. If the corresponding bit in this register is set to '0', the value of this bit in the GSR Register is the actual value of the input pin. The MSB of this register corresponds with P7 and the LSB of this register corresponds with P0.

GPIO Configuration Register (GCR)—Read/Write

This register configures the GPIOs as inputs or outputs. After power-up or after reset, the GPIOs are inputs. Setting these bits to '0' enables the GPIOs as outputs. Setting these bits to '1' enable the GPIOs as inputs. The MSB of this register corresponds with P7 and the LSB of this register corresponds with P0.

Input Internal Pull-up Enable/Disable Register (PUR)—Read/Write

This register enables/disables the internal pull-up resistors for an input. After power-up, the internal pull-up resistors are disabled for the MxL82200. Writing a '1' to these bits enableS the internal pull-up resistors. After power-up, the internal pull-up resistors are enabled for the MxL82210. Writing a '0' to these bits disables the Internal pull-up resistors. The MSB of this register corresponds with P7 and the LSB of this register corresponds with P0

Input Interrupt Enable Register (IER)—Read/Write

This register enables/disables the interrupts for an input. After power-up or after reset, the interrupts are disabled. Writing a '1' to these bits enable the interrupt for the corresponding input pins. For complete details of the interrupt behavior for various register settings, see [Table 7](#) on page 10. No interrupts are generated for outputs when GCR bit is 0. The MSB of this register corresponds with P7 and the LSB of this register corresponds with P0.

Output Three-State Control Register (TSCR)—Read/Write

This register can enable/disable the three-state mode of an output. Writing a '1' to these bits enable the three-state mode for the corresponding output pins. The MSB of this register corresponds with P7 and the LSB of this register corresponds with P0.

Input Interrupt Status Register (ISR)—Read-Only

This register reports the input pins that have generated an interrupt. For complete details of the interrupt behavior for various register settings, see [Table 7](#) on page 10. The MSB of this register corresponds with P7 and the LSB of this register corresponds with P0.

Input Rising Edge Interrupt Enable Register (REIR)—Read/Write

Writing a '1' to these bits enable the corresponding input to generate an interrupt on the rising edge. For complete details of the interrupt behavior for various register settings, see [Table 7](#) on page 10. The MSB of this register corresponds with P7 and the LSB of this register corresponds with P0.

Input Falling Edge Interrupt Enable Register (FEIR)—Read/Write

Writing a '1' to these bits enable the corresponding input to generate an interrupt on the falling edge. Writing a '1' to these bits make that input generate an interrupt on the rising edge only. For complete details of the interrupt behavior for various register settings, see [Table 7](#) on page 10. The MSB of this register corresponds with P7 and the LSB of this register corresponds with P0.

Input Filter Enable Register (IFR)—Read/Write

By default, the input filters are enabled (IFR = 0xFF). When the input filters are enabled, any pulse that is greater than 1075ns generates an interrupt (if enabled). Pulses that are less than 225ns are filtered and do not generate an interrupt. Pulses in between this range may or may not generate an interrupt. Writing a '0' to these bits disable the input filter for the corresponding inputs. With the input filters disabled, any change on the inputs generates an interrupt (if enabled). For complete details of the interrupt behavior for various register settings, see [Table 7](#) on page 10. The MSB of this register corresponds with P7 and the LSB of this register corresponds with P0.

Mechanical Dimensions

16-Pin QFN

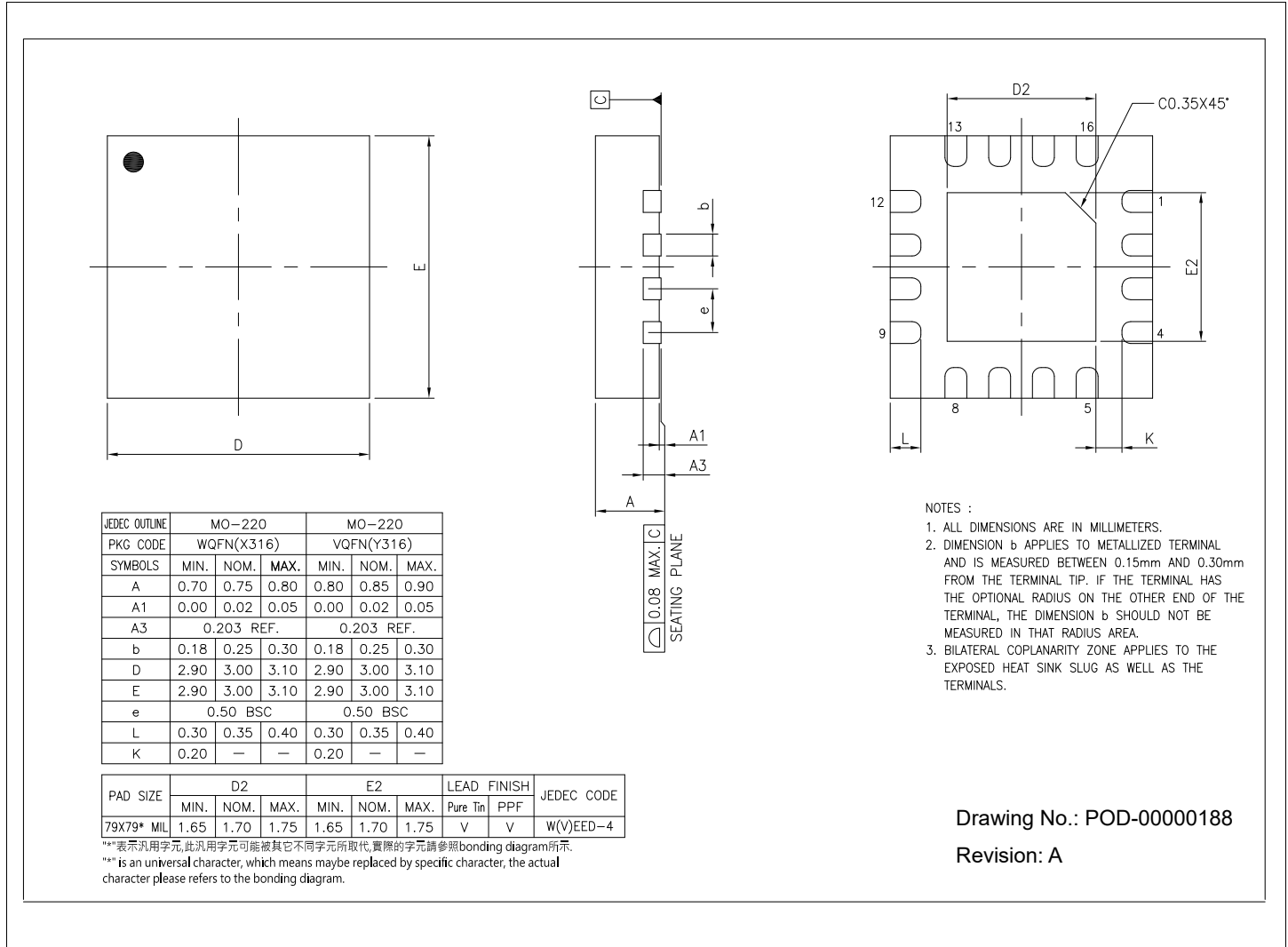
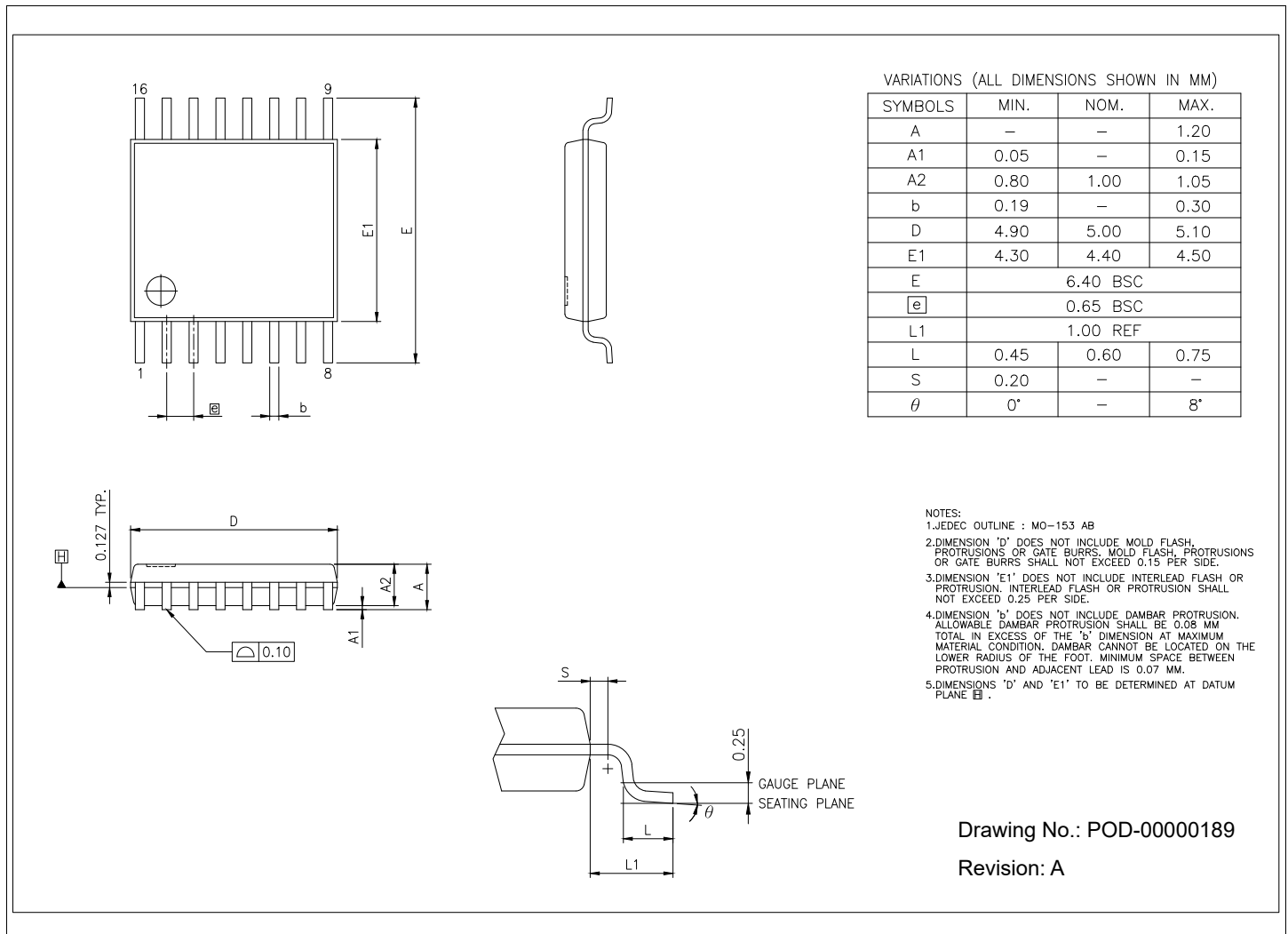

Figure 7: QFN-16 Mechanical Dimensions

16-Pin TSSOP



VARIATIONS (ALL DIMENSIONS SHOWN IN MM)

SYMBOLS	MIN.	NOM.	MAX.
A	—	—	1.20
A1	0.05	—	0.15
A2	0.80	1.00	1.05
b	0.19	—	0.30
D	4.90	5.00	5.10
E1	4.30	4.40	4.50
E	6.40 BSC		
e	0.65 BSC		
L1	1.00 REF		
L	0.45	0.60	0.75
S	0.20	—	—
θ	0°	—	8°

- NOTES:
1. JEDEC OUTLINE : MO-153 AB
 2. DIMENSION 'D' DOES NOT INCLUDE MOLD FLASH, PROTRUSIONS OR GATE BURRS. MOLD FLASH, PROTRUSIONS OR GATE BURRS SHALL NOT EXCEED 0.15 PER SIDE.
 3. DIMENSION 'E1' DOES NOT INCLUDE INTERLEAD FLASH OR PROTRUSION. INTERLEAD FLASH OR PROTRUSION SHALL NOT EXCEED 0.25 PER SIDE.
 4. DIMENSION 'b' DOES NOT INCLUDE DAMBAR PROTRUSION. ALLOWABLE DAMBAR PROTRUSION SHALL BE 0.08 MM TOTAL IN EXCESS OF THE 'b' DIMENSION AT MAXIMUM MATERIAL CONDITION. DAMBAR CANNOT BE LOCATED ON THE LOWER RADIUS OF THE FOOT. MINIMUM SPACE BETWEEN PROTRUSION AND ADJACENT LEAD IS 0.07 MM.
 5. DIMENSIONS 'D' AND 'E1' TO BE DETERMINED AT DATUM PLANE \square .

Drawing No.: POD-00000189

Revision: A

Figure 8: TSSOP-16 Mechanical Dimensions

Ordering Information

Table 8: Ordering Information

Ordering Part Number	Package	Number of GPIOs	Operating Temperature Range	Packing Method	Lead-Free
MXL82200I-AGA-R	TSSOP-16	8	-40°C to 85°C	Tape and Reel	Yes
MXL82200I-AQB-R	QFN-16	8	-40°C to 85°C	Tape and Reel	Yes
MxL82210I-AGA-R	TSSOP-16	8	-40°C to 85°C	Tape and Reel	Yes
MxL82210I-AQB-R	QFN-16	8	-40°C to 85°C	Tape and Reel	Yes



Corporate Headquarters:
 5966 La Place Court, Suite 100
 Carlsbad, CA 92008
 Tel.: +1 (760) 692-0711
 Fax: +1 (760) 444-8598
www.maxlinear.com

The content of this document is furnished for informational use only, is subject to change without notice, and should not be construed as a commitment, representation, or warranty by MaxLinear, Inc. or any of its affiliates (collectively, "MaxLinear"). MaxLinear assumes no responsibility or liability for any errors, omissions, or inaccuracies that may appear in the informational content contained in this document. Complying with all applicable copyright laws is the responsibility of the user. Without limiting the rights under copyright, no part of this document may be reproduced, stored in, or introduced into a retrieval system, or transmitted in any form or by any means (electronic, mechanical, photocopying, recording, or otherwise), or for any purpose, without the express prior written permission of MaxLinear.

EXCEPT AS OTHERWISE PROVIDED EXPRESSLY IN WRITING BY MAXLINEAR, AND TO THE MAXIMUM EXTENT PERMITTED BY APPLICABLE LAW: (A) THE MAXLINEAR PRODUCTS ARE PROVIDED ON AN "AS IS" BASIS WITHOUT REPRESENTATIONS OR WARRANTIES OF ANY KIND, INCLUDING WITHOUT LIMITATION ANY IMPLIED OR STATUTORY WARRANTIES AND ANY WARRANTIES OF MERCHANTABILITY, FITNESS FOR A PARTICULAR PURPOSE, NON-INFRINGEMENT, OR TITLE; AND (B) MAXLINEAR DOES NOT WARRANT OR GUARANTEE THAT THE PRODUCTS WILL BE FREE OF ERRORS OR DEFECTS. MAXLINEAR PRODUCTS ARE NOT DESIGNED, INTENDED, AUTHORIZED, OR WARRANTED FOR USE IN ANY EMERGENCY, SECURITY, MILITARY, LIFE-SAVING, LIFE-SUSTAINING, OR OTHER CRITICAL USE CASE WHERE A FAILURE OR MALFUNCTION COULD REASONABLY BE EXPECTED TO CAUSE PERSONAL INJURY OR DEATH, OR DAMAGE TO OR LOSS OF PROPERTY. USERS ASSUME ALL RISK FOR USING THE MAXLINEAR PRODUCTS IN SUCH USE CASE. CUSTOMERS AND USERS ARE SOLELY RESPONSIBLE FOR USING THEIR OWN SKILL AND JUDGMENT TO DETERMINE WHETHER MAXLINEAR PRODUCTS ARE SUITABLE FOR THEIR INTENDED USE CASE, AND FOR CONDUCTING APPROPRIATE TESTING AND EVALUATION OF THE PRODUCTS FOR SUCH USE.

MaxLinear may have patents, patent applications, trademarks, copyrights, trade secrets, or other intellectual property rights covering subject matter in this document. Except as expressly provided in any written license agreement from MaxLinear, the furnishing of this document does not give you any license to these patents, patent applications, trademarks, copyrights, trade secrets, or other intellectual property.

MaxLinear, the MaxLinear logo, and any other MaxLinear trademarks (including but not limited to MxL, Full-Spectrum Capture, FSC, AirPHY, Puma, AnyWAN, VectorBoost, MXL WARE, and Panther) are all property of MaxLinear and/or its subsidiaries in the U.S.A. and other countries. All rights reserved.

All third-party marks and logos are trademarks™ or registered® trademarks of their respective holders/owners. Use of such marks by MaxLinear does not imply any affiliation with, sponsorship, or endorsement by or of the owners/holders of such trademarks. All references by MaxLinear to third-party trademarks are intended to constitute nominative fair use under applicable trademark laws and are used solely for purposes of identification and description.

Any URLs or third-party references provided are for informational purposes only; they do not constitute an endorsement or an approval by MaxLinear of any of the products, services, or content of any third-party corporation, organization, or individual. MaxLinear bears no responsibility or liability for the accuracy, legality, availability, or content of any external site or for that of subsequent links. Contact the external site for answers to questions regarding its content.