



A New Direction in Mixed-Signal

CLC1007, CLC2007, CLC4007

Single, Dual, and Quad Low Cost, High Speed RRO Amplifiers

General Description

The CLC1007 (single), CLC2007 (dual) and CLC4007(quad) are low cost, voltage feedback amplifiers. These amplifiers are designed to operate on +3V to +5V, or $\pm 5V$ supplies. The input voltage range extends 300mV below the negative rail and 0.9V below the positive rail.

The CLC1007, CLC2007, and CLC4007 offer superior dynamic performance with a 260MHz small signal bandwidth and 220V/ μ s slew rate. The combination of low power, high output current drive, and rail-to-rail performance make these amplifiers well suited for battery-powered communication/computing systems.

The combination of low cost and high performance make the CLC1007, CLC2007, and CLC4007 suitable for high volume applications in both consumer and industrial applications such as wireless phones, scanners, color copiers, and video transmission.

FEATURES

- 260MHz bandwidth
- Fully specified at +3V, +5V and $\pm 5V$ supplies
- Output voltage range:
 - 0.03V to 4.95V; $V_S = +5$; $R_L = 2k\Omega$
- Input voltage range:
 - -0.3V to +4.1V; $V_S = +5$
- 220V/ μ s slew rate
- 2.6mA supply current per amplifier
- ± 100 mA linear output current
- ± 125 mA short circuit current
- CLC2007 directly replaces LMH6643, AD8042, AD8052, and AD8092
- CLC1007 directly replaces LMH6642, AD8041, AD8051, and AD8091

APPLICATIONS

- A/D driver
- Active filters
- CCD imaging systems
- CD/DVD ROM
- Coaxial cable drivers
- High capacitive load driver
- Portable/battery-powered applications
- Twisted pair driver
- Telecom and optical terminals
- Video driver

Ordering Information - [page 26](#)

Large Signal Frequency Response

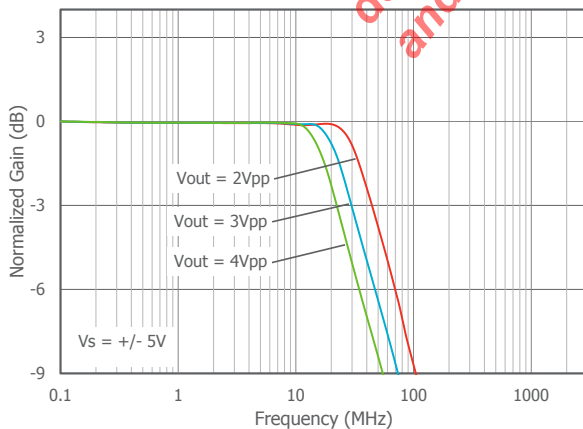

Output Voltage Swing vs Competition

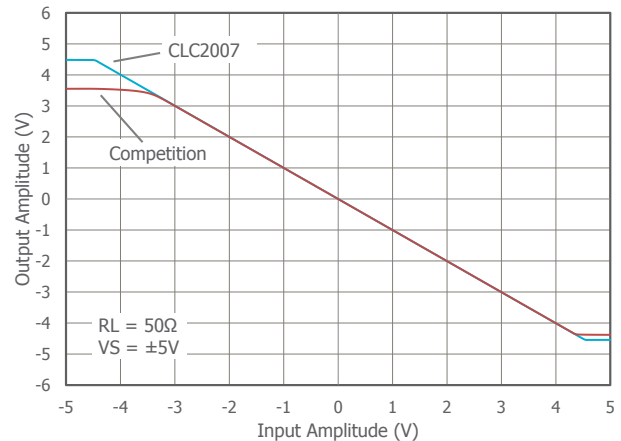

Absolute Maximum Ratings

Stresses beyond the limits listed below may cause permanent damage to the device. Exposure to any Absolute Maximum Rating condition for extended periods may affect device reliability and lifetime.

V_S 0V to +14V
 V_{IN} $-V_S - 0.5V$ to $+V_S + 0.5V$

Operating Conditions

Supply Voltage Range 2.7 to 12.6V
 Operating Temperature Range -40°C to 125°C
 Junction Temperature 150°C
 Storage Temperature Range -65°C to 150°C
 Lead Temperature (Soldering, 10s) 260°C

Package Thermal Resistance

θ_{JA} (TSOT23-5) 215°C/W
 θ_{JA} (SOIC-8) 150°C/W
 θ_{JA} (MSOP-8) 200°C/W
 θ_{JA} (SOIC-14) 90°C/W
 θ_{JA} (TSSOP-14) 100°C/W
 Package thermal resistance (θ_{JA}), JEDEC standard, multi-layer test boards, still air.

ESD Protection

TSOT-5 (HBM) 1kV
 SOIC-8 (HBM) 1kV
 TSOT-5 (CDM) 2kV
 SOIC-8 (CDM) 2kV
 ESD Rating for HBM (Human Body Model) and CDM (Charged Device Model).

The product (or products) mentioned in this data sheet are no longer being manufactured and may not be ordered (Q15)

Electrical Characteristics at +3V

$T_A = 25^\circ\text{C}$, $V_S = +3\text{V}$, $R_f = 1.5\text{k}\Omega$, $R_L = 2\text{k}\Omega$ to $V_S/2$; $G = 2$; unless otherwise noted.

Symbol	Parameter	Conditions	Min	Typ	Max	Units
Frequency Domain Response						
GBWP	-3dB Gain Bandwidth Product	$G = +11$, $V_{OUT} = 0.2V_{pp}$		90		MHz
UGBW	Unity Gain Bandwidth	$V_{OUT} = 0.2V_{pp}$, $R_F = 0$		245		MHz
BW _{SS}	-3dB Bandwidth	$V_{OUT} = 0.2V_{pp}$		85		MHz
$f_{0.1dB}$	0.1dB Gain Flatness	$V_{OUT} = 0.2V_{pp}$, $R_L = 150\Omega$		16		MHz
BW _{LS}	Large Signal Bandwidth	$V_{OUT} = 2V_{pp}$		55		MHz
DG	Differential Gain	DC-coupled Output		0.03		%
		AC-coupled Output		0.04		%
DP	Differential Phase	DC-coupled Output		0.03		°
		AC-coupled Output		0.06		°
Time Domain						
t_R , t_F	Rise and Fall Time	$V_{OUT} = 0.2\text{V}$ step; (10% to 90%)		5		ns
t_S	Settling Time to 0.1%	$V_{OUT} = 1\text{V}$ step		25		ns
OS	Overshoot	$V_{OUT} = 0.2\text{V}$ step		8		%
SR	Slew Rate	$G = -1$, 2V step		175		V/ μs
Distortion/Noise Response						
THD	Total Harmonic Distortion	1MHz, $V_{OUT} = 1V_{pp}$		75		dBc
e_n	Input Voltage Noise	>50kHz		16		nV/ $\sqrt{\text{Hz}}$
X _{TALK}	Crosstalk	$f = 5\text{MHz}$		58		dB
DC Performance						
V_{IO}	Input Offset Voltage			0.5		mV
d_{VIO}	Average Drift			5		$\mu\text{V}/^\circ\text{C}$
I_B	Input Bias Current			1.4		μA
dI_B	Average Drift			2		nA/ $^\circ\text{C}$
I_{OS}	Input Offset Current			0.05		μA
PSRR	Power Supply Rejection Ratio	DC		102		dB
A_{OL}	Open Loop Gain	$R_L = 2\text{k}\Omega$		92		dB
I_S	Supply Current	per channel		2.6		mA
Input Characteristics						
C_{IN}	Input Capacitance			0.5		pF
CMIR	Common Mode Input Range			-0.3 to 2.1		V
CMRR	Common Mode Rejection Ratio	DC, $V_{CM} = 0$ to 1.5V		100		dB
Output Characteristics						
V_{OUT}	Output Swing	$R_L = 150\Omega$		0.3 to 2.75		V
		$R_L = 2\text{k}\Omega$		0.02 to 2.96		V
I_{OUT}	Output Current			± 100		mA
I_{SC}	Short Circuit Current	$V_{OUT} = V_S / 2$		± 125		V
V_S	Power Supply Operating Range			2.7 to 12.6		V

Electrical Characteristics at +5V

$T_A = 25^\circ\text{C}$, $V_S = +5\text{V}$, $R_f = 1.5\text{k}\Omega$, $R_L = 2\text{k}\Omega$ to $V_S/2$; $G = 2$; unless otherwise noted.

Symbol	Parameter	Conditions	Min	Typ	Max	Units
Frequency Domain Response						
GBWP	-3dB Gain Bandwidth Product	$G = +11$, $V_{OUT} = 0.2V_{pp}$		95		MHz
UGBW	Unity Gain Bandwidth	$V_{OUT} = 0.2V_{pp}$, $R_F = 0$		250		MHz
BW _{SS}	-3dB Bandwidth	$V_{OUT} = 0.2V_{pp}$		85		MHz
$f_{0.1dB}$	0.1dB Gain Flatness	$V_{OUT} = 0.2V_{pp}$, $R_L = 150\Omega$		35		MHz
BW _{LS}	Large Signal Bandwidth	$V_{OUT} = 2V_{pp}$		65		MHz
DG	Differential Gain	DC-coupled Output		0.03		%
		AC-coupled Output		0.04		%
DP	Differential Phase	DC-coupled Output		0.03		°
		AC-coupled Output		0.06		°
Time Domain						
t_R , t_F	Rise and Fall Time	$V_{OUT} = 0.2\text{V}$ step		5		ns
t_S	Settling Time to 0.1%	$V_{OUT} = 2\text{V}$ step		25		ns
OS	Overshoot	$V_{OUT} = 0.2\text{V}$ step		5		%
SR	Slew Rate	$G = -1$, 4V step		220		V/ μs
Distortion/Noise Response						
THD	Total Harmonic Distortion	1MHz, $V_{OUT} = 2V_{pp}$		-75		dBc
e_n	Input Voltage Noise	>50kHz		16		nV/ $\sqrt{\text{Hz}}$
X _{TALK}	Crosstalk	$f = 5\text{MHz}$		58		dB
DC Performance						
V_{IO}	Input Offset Voltage		-7	0.5	7	mV
d_{VIO}	Average Drift			5		$\mu\text{V}/^\circ\text{C}$
I_B	Input Bias Current		-2	1.4	2	μA
dI_B	Average Drift			2		nA/ $^\circ\text{C}$
I_{OS}	Input Offset Current		-0.75	0.05	0.75	μA
PSRR	Power Supply Rejection Ratio	DC	80	102		dB
A_{OL}	Open Loop Gain	$R_L = 2\text{k}\Omega$	80	92		dB
I_S	Supply Current	per channel		2.6	4	mA
Input Characteristics						
C_{IN}	Input Capacitance			0.5		pF
CMIR	Common Mode Input Range			-0.3 to 4.1		V
CMRR	Common Mode Rejection Ratio	DC, $V_{CM} = 0$ to 3.5V	75	100		dB
Output Characteristics						
V_{OUT}	Output Swing	$R_L = 150\Omega$	0.35	0.1 to 4.9	4.65	V
		$R_L = 2\text{k}\Omega$		0.03 to 4.95		V
I_{OUT}	Output Current			± 100		mA
I_{SC}	Short Circuit Current	$V_{OUT} = V_S / 2$		± 125		V
V_S	Power Supply Operating Range			2.7 to 12.6		V

Electrical Characteristics at $\pm 5V$

$T_A = 25^\circ\text{C}$, $V_S = \pm 5V$, $R_f = 1.5k\Omega$, $R_L = 2k\Omega$ to GND; $G = 2$; unless otherwise noted.

Symbol	Parameter	Conditions	Min	Typ	Max	Units
Frequency Domain Response						
GBWP	-3dB Gain Bandwidth Product	$G = +11$, $V_{OUT} = 0.2V_{pp}$		90		MHz
UGBW	Unity Gain Bandwidth	$V_{OUT} = 0.2V_{pp}$, $R_F = 0$		260		MHz
BW _{SS}	-3dB Bandwidth	$V_{OUT} = 0.2V_{pp}$		85		MHz
$f_{0.1dB}$	0.1dB Gain Flatness	$V_{OUT} = 0.2V_{pp}$, $R_L = 150\Omega$		22		MHz
BW _{LS}	Large Signal Bandwidth	$V_{OUT} = 2V_{pp}$		65		MHz
DG	Differential Gain	DC-coupled Output		0.03		%
		AC-coupled Output		0.04		%
DP	Differential Phase	DC-coupled Output		0.03		°
		AC-coupled Output		0.06		°
Time Domain						
t_R , t_F	Rise and Fall Time	$V_{OUT} = 0.2V$ step		5		ns
t_S	Settling Time to 0.1%	$V_{OUT} = 2V$ step, $R_L = 100\Omega$		25		ns
OS	Overshoot	$V_{OUT} = 0.2V$ step		5		%
SR	Slew Rate	$G = -1$, $5V$ step		225		V/ μ s
Distortion/Noise Response						
THD	Total Harmonic Distortion	1MHz, $V_{OUT} = 2V_{pp}$		76		dBc
e_n	Input Voltage Noise	>50kHz		16		nV/ $\sqrt{\text{Hz}}$
X _{TALK}	Crosstalk	$f = 5\text{MHz}$		58		dB
DC Performance						
V_{IO}	Input Offset Voltage			0.5		mV
d_{VIO}	Average Drift			5		$\mu\text{V}/^\circ\text{C}$
I_B	Input Bias Current			1.3		μA
dI_B	Average Drift			2		nA/ $^\circ\text{C}$
I_{OS}	Input Offset Current			0.04		μA
PSRR	Power Supply Rejection Ratio	DC		102		dB
A_{OL}	Open Loop Gain	$R_L = 2k\Omega$		92		dB
I_S	Supply Current	per channel		2.6		mA
Input Characteristics						
C_{IN}	Input Capacitance			0.5		pF
CMIR	Common Mode Input Range			-5.3 to 4.1		V
CMRR	Common Mode Rejection Ratio	DC, $V_{CM} = -5$ to $3.5V$		100		dB
Output Characteristics						
V_{OUT}	Output Swing	$R_L = 150\Omega$		-4.8 to 4.8		V
		$R_L = 2k\Omega$		-4.95 to 4.93		V
I_{OUT}	Output Current			± 100		mA
I_{SC}	Short Circuit Current	$V_{OUT} = V_S / 2$		± 125		V
V_S	Power Supply Operating Range			2.7 to 12.6		V

CLC1007 Pin Configurations

TSOT-5

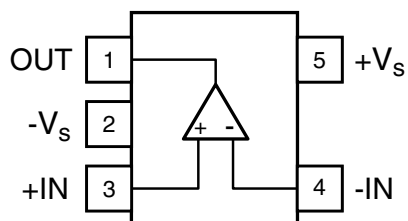

CLC1007 Pin Assignments

TSOT-5

Pin No.	Pin Name	Description
1	OUT	Output
2	-V _S	Negative supply
3	+IN	Positive input
4	-IN	Negative input
5	+V _S	Positive supply

SOIC-8

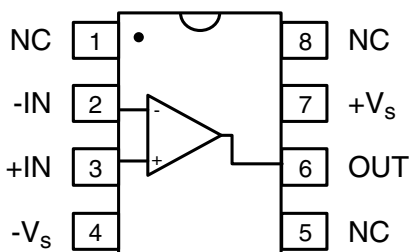

SOIC-8

Pin No.	Pin Name	Description
1	NC	No Connect
2	-IN	Negative input
3	+IN	Positive input
4	-V _S	Negative supply
5	NC	No Connect
6	OUT	Output
7	+V _S	Positive supply
8	NC	No Connect

CLC2007 Pin Configuration

SOIC-8 / MSOP-8

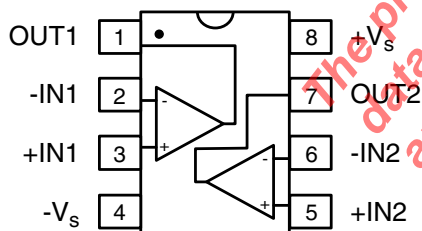

CLC2007 Pin Assignments

SOIC-8 / MSOP-8

Pin No.	Pin Name	Description
1	OUT1	Output, channel 1
2	-IN1	Negative input, channel 1
3	+IN1	Positive input, channel 1
4	-V _S	Negative supply
5	+IN2	Positive input, channel 2
6	-IN2	Negative input, channel 2
7	OUT2	Output, channel 2
8	+V _S	Positive supply

CLC4007 Pin Configuration

SOIC-14 / TSSOP-14

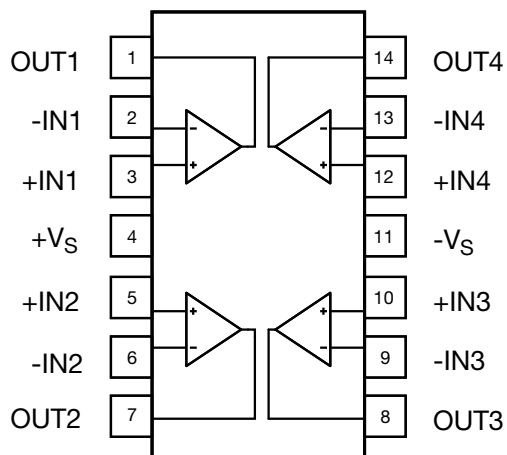

CLC4007 Pin Assignments

SOIC-14 / TSSOP-14

Pin No.	Pin Name	Description
1	OUT1	Output, channel 1
2	-IN1	Negative input, channel 1
3	+IN1	Positive input, channel 1
4	+Vs	Positive supply
5	+IN2	Positive input, channel 2
6	-IN2	Negative input, channel 2
7	OUT2	Output, channel 2
8	OUT3	Output, channel 3
9	-IN3	Negative input, channel 3
10	+IN3	Positive input, channel 3
11	-Vs	Negative supply
12	+IN4	Positive input, channel 4
13	-IN4	Negative input, channel 4
14	OUT4	Output, channel 4

The product (or products) mentioned in this data sheet are no longer being manufactured and may not be ordered (OBS)

Typical Performance Characteristics at +3V

$T_A = 25^\circ\text{C}$, $V_S = +3\text{V}$, $R_L = 2\text{k}\Omega$ to $V_S/2$, $G = +2$, $R_F = 1.5\text{k}\Omega$; unless otherwise noted.

Non-Inverting Frequency Response

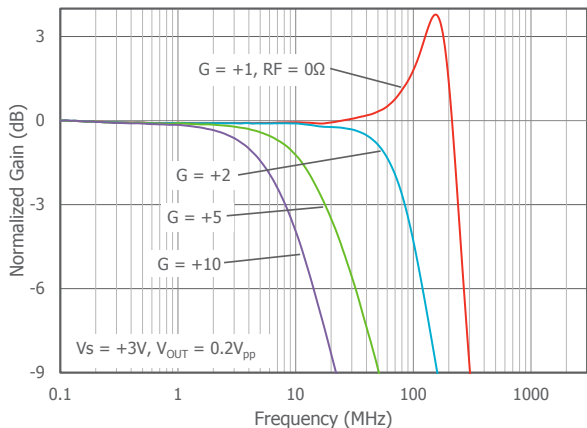

Inverting Frequency Response

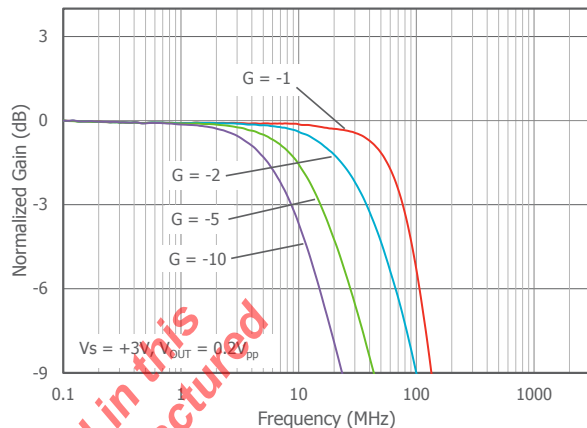

Frequency Response vs C_L

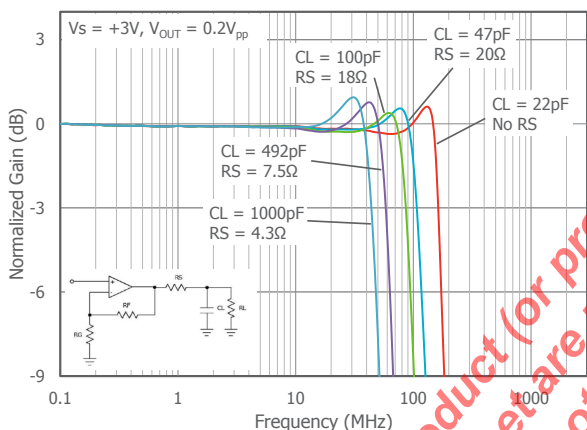

Frequency Response vs R_L

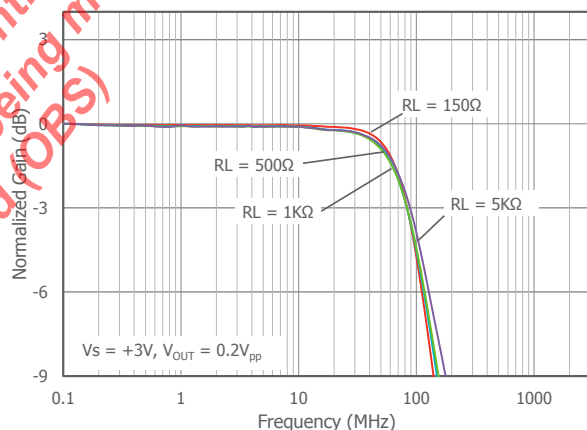

Large Signal Frequency Response

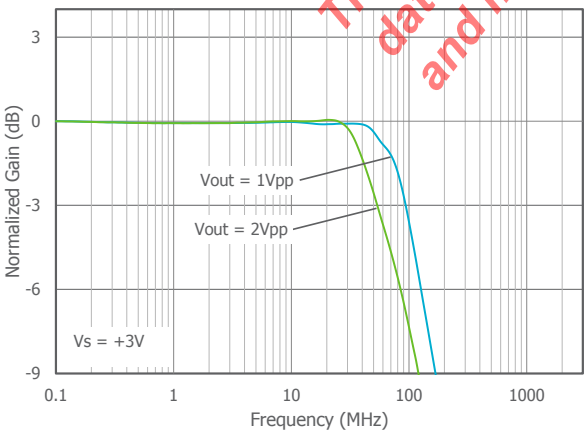

-3dB BW vs Output Voltage

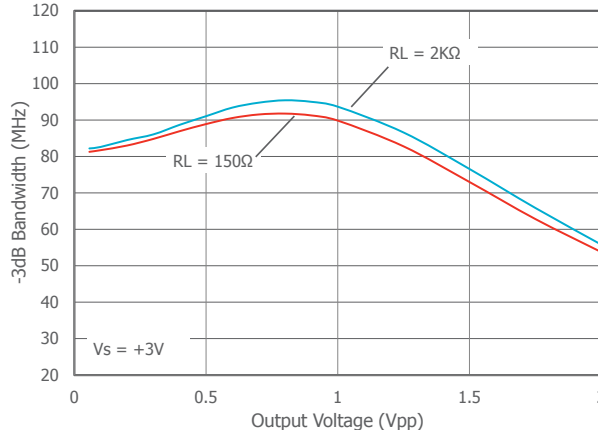

The product (or products) mentioned in this data sheet are no longer being manufactured and may not be ordered (OBS)

Typical Performance Characteristics at +3V

$T_A = 25^\circ\text{C}$, $V_S = +3\text{V}$, $R_L = 2\text{k}\Omega$ to $V_S/2$, $G = +2$, $R_F = 1.5\text{k}\Omega$; unless otherwise noted.

Input Voltage Noise vs Frequency

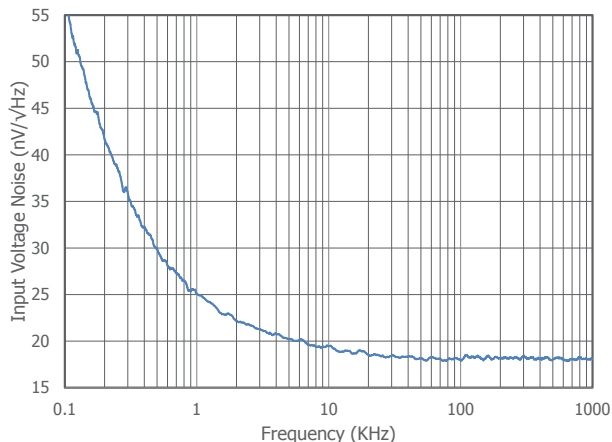

2nd Harmonic Distortion vs R_L over Frequency

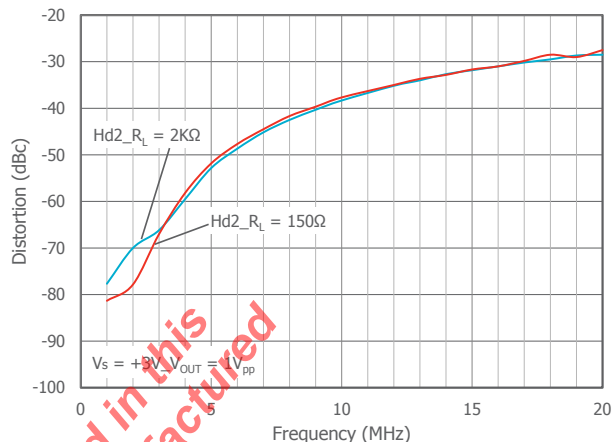

3rd Harmonic Distortion vs R_L over Frequency

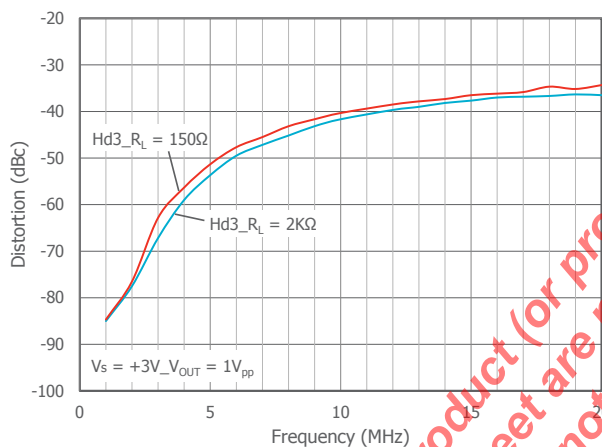

2nd Harmonic Distortion vs V_O over Frequency

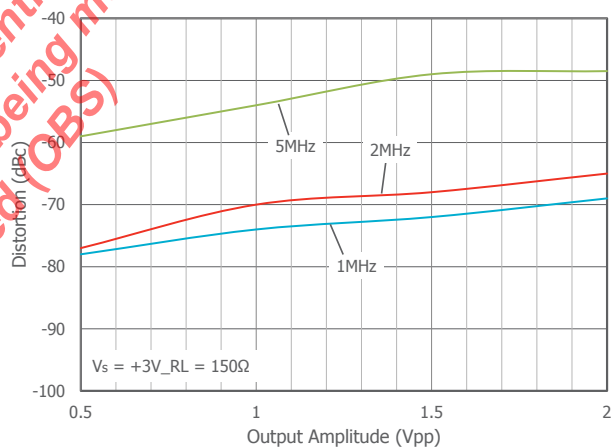

3rd Harmonic Distortion vs V_O over Frequency

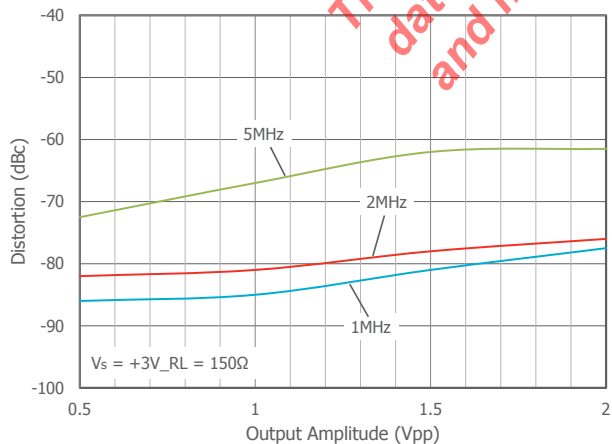

Non-Inverting Small Signal Pulse Response

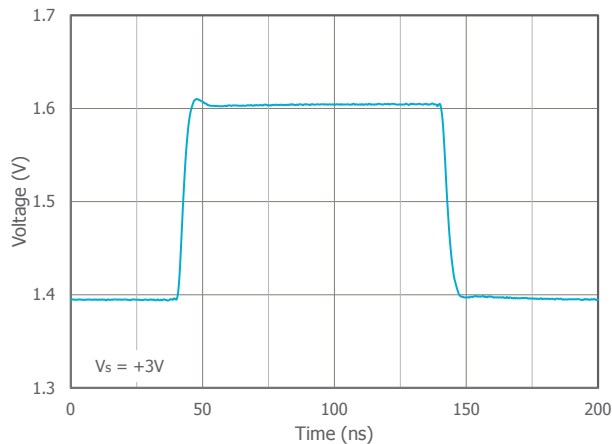

The product (or products) mentioned in this data sheet are no longer being manufactured and may not be ordered (OBS)

Typical Performance Characteristics at +3V

$T_A = 25^\circ\text{C}$, $V_S = +3\text{V}$, $R_L = 2\text{k}\Omega$ to $V_S/2$, $G = +2$, $R_F = 1.5\text{k}\Omega$; unless otherwise noted.

Non-Inverting Large Signal Pulse Response

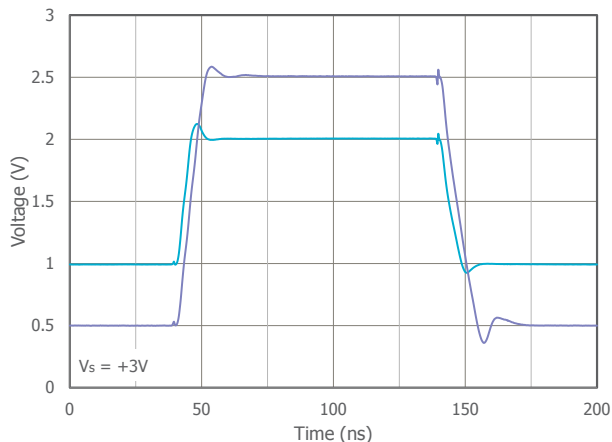

Crosstalk vs Frequency (CLC2007)

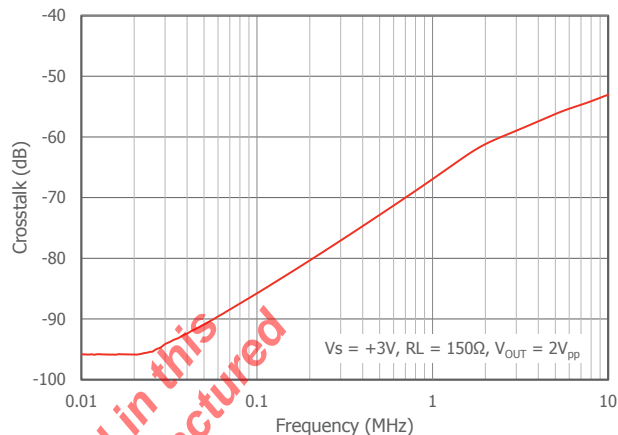

Differential Gain & Phase_DC Coupled

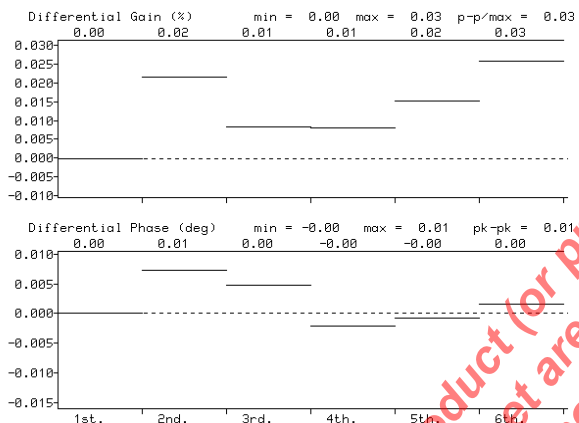

Differential Gain & Phase_AC Coupled

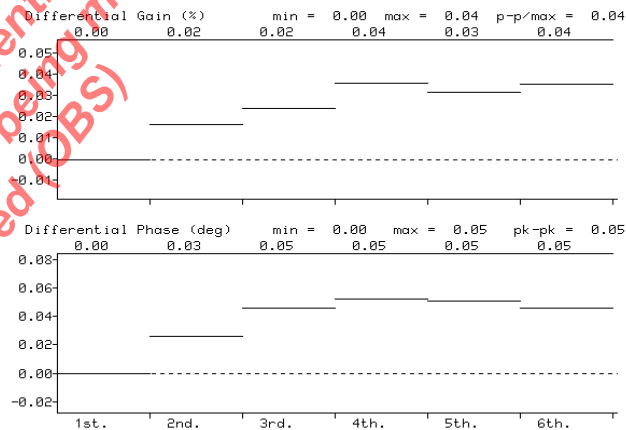

The product (or products) mentioned in this data sheet are no longer being manufactured and may not be ordered (DSS)

Typical Performance Characteristics at +5V

$T_A = 25^\circ\text{C}$, $V_S = +5\text{V}$, $R_L = 2\text{k}\Omega$ to $V_S/2$, $G = +2$, $R_F = 1.5\text{k}\Omega$; unless otherwise noted.

Non-Inverting Frequency Response

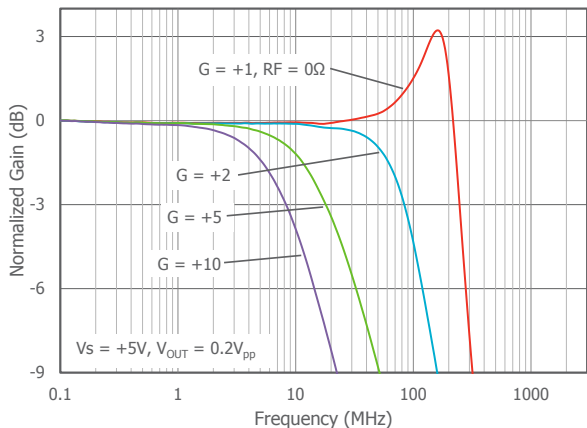

Inverting Frequency Response

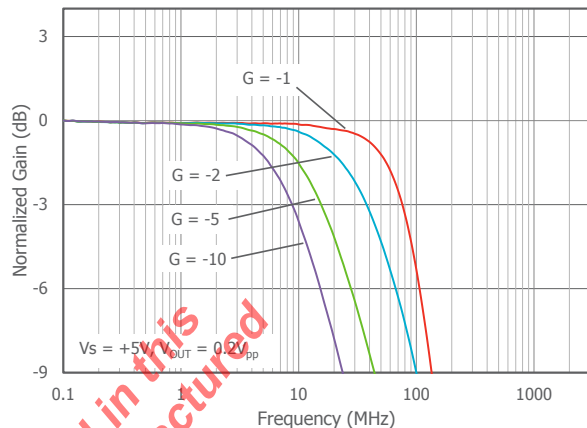

Frequency Response vs C_L

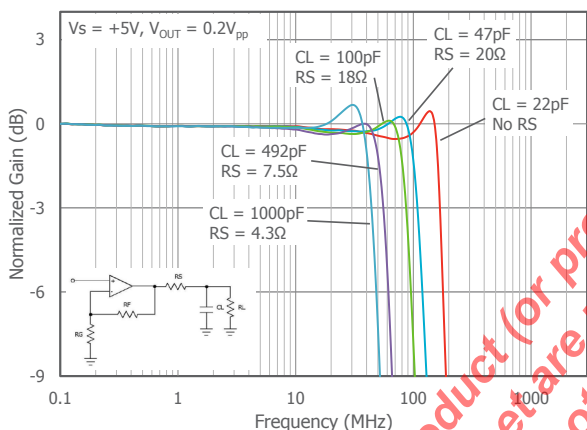

Frequency Response vs R_L

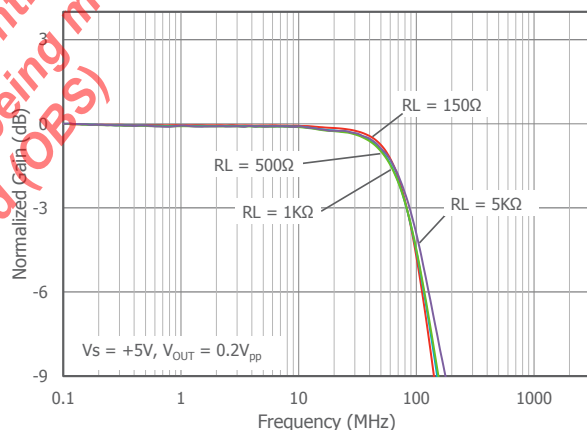

Large Signal Frequency Response

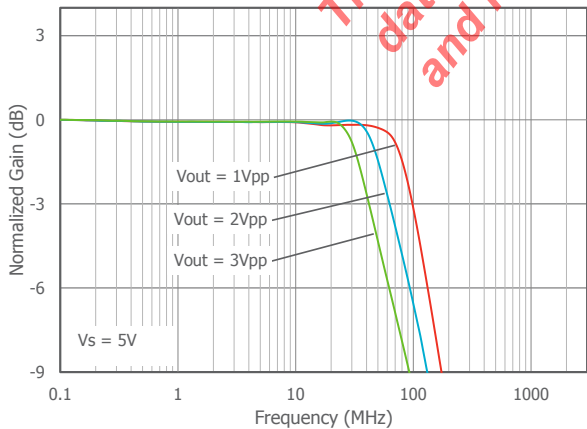

-3dB BW vs Output Voltage

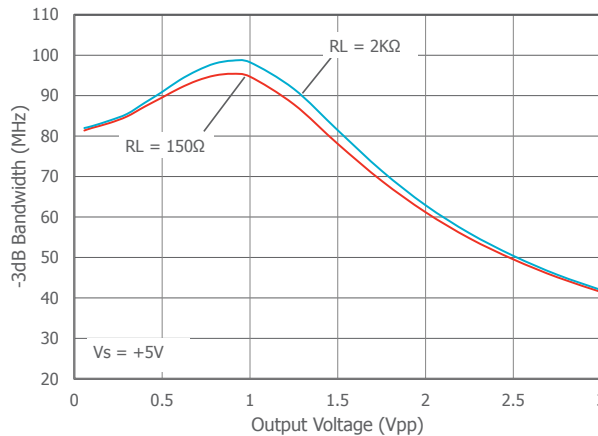

The product (or products) mentioned in this data sheet are no longer being manufactured and may not be ordered (OBS)

Typical Performance Characteristics at +5V

$T_A = 25^\circ\text{C}$, $V_S = +5\text{V}$, $R_L = 2\text{k}\Omega$ to $V_S/2$, $G = +2$, $R_F = 1.5\text{k}\Omega$; unless otherwise noted.

Input Voltage Noise vs Frequency

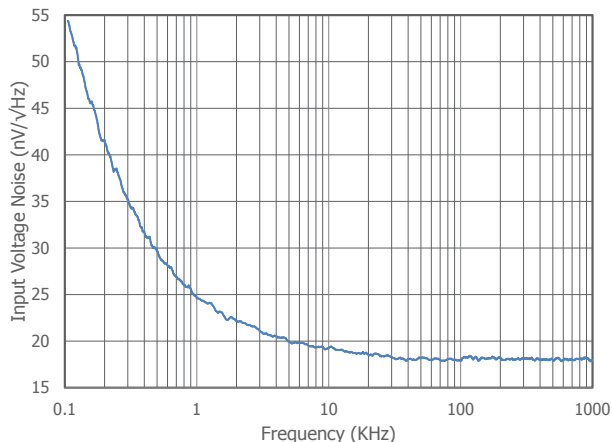

2nd Harmonic Distortion vs R_L over Frequency

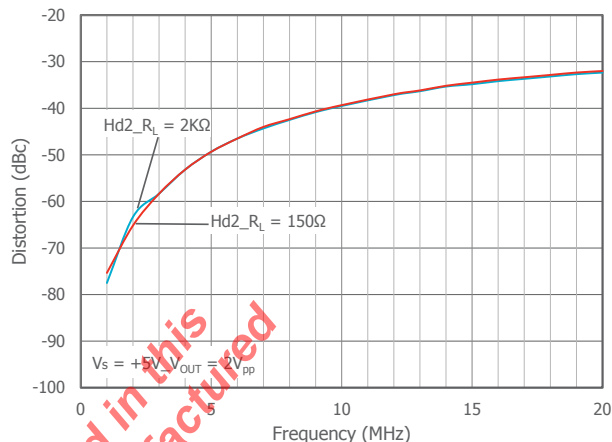

3rd Harmonic Distortion vs R_L over Frequency

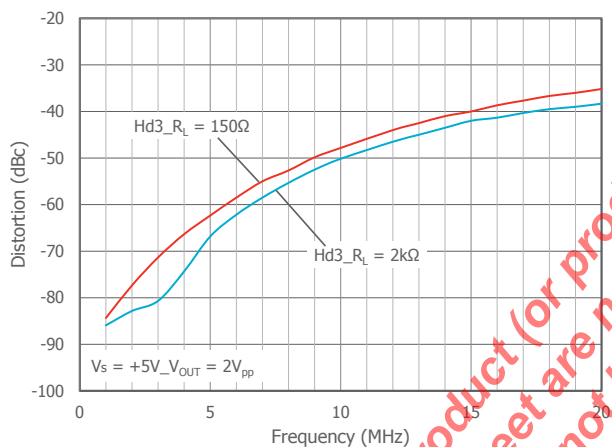

2nd Harmonic Distortion vs V_O over Frequency

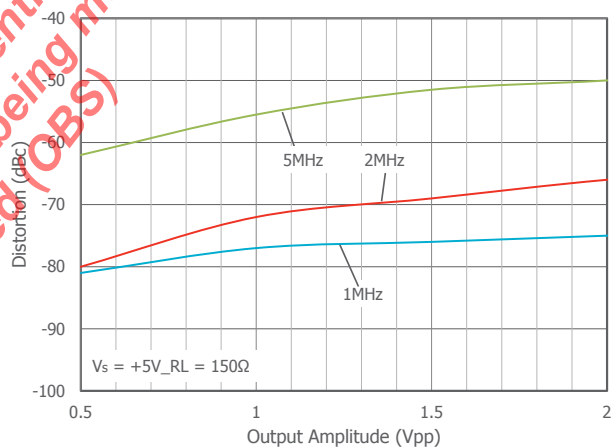

3rd Harmonic Distortion vs V_O over Frequency

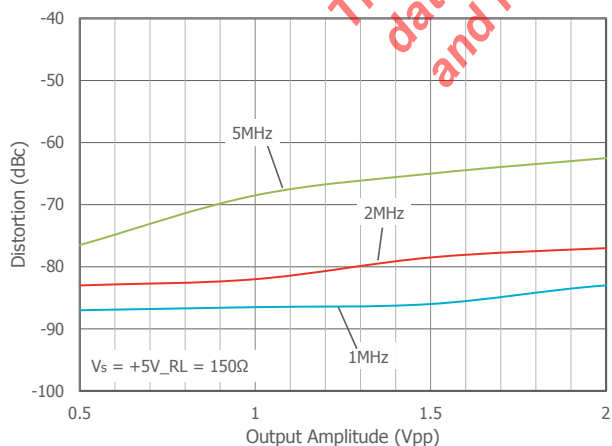

Non-Inverting Small Signal Pulse Response

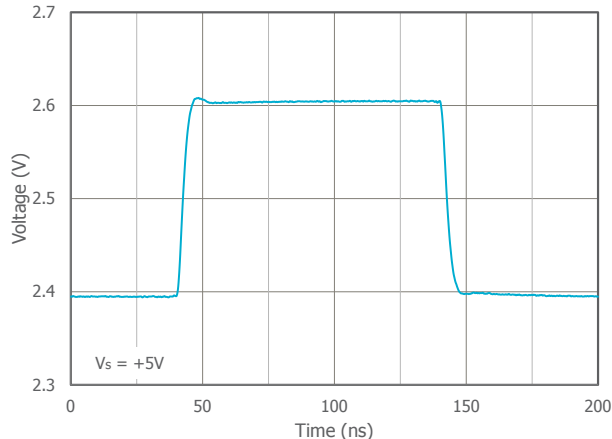

The product (or products) mentioned in this data sheet are no longer being manufactured and may not be ordered (OBS)

Typical Performance Characteristics at +5V

$T_A = 25^\circ\text{C}$, $V_S = +5\text{V}$, $R_L = 2\text{k}\Omega$ to $V_S/2$, $G = +2$, $R_F = 1.5\text{k}\Omega$; unless otherwise noted.

Non-Inverting Large Signal Pulse Response

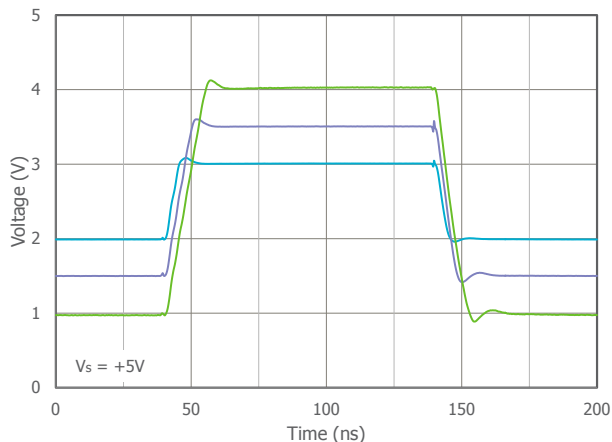

Crosstalk vs Frequency (CLC2007)

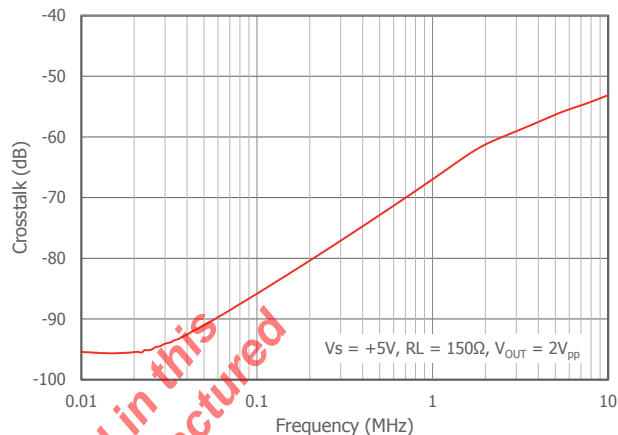

Differential Gain & Phase_DC Coupled

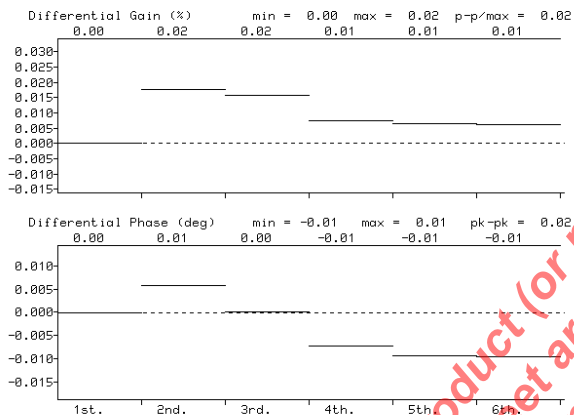

Differential Gain & Phase_AC Coupled

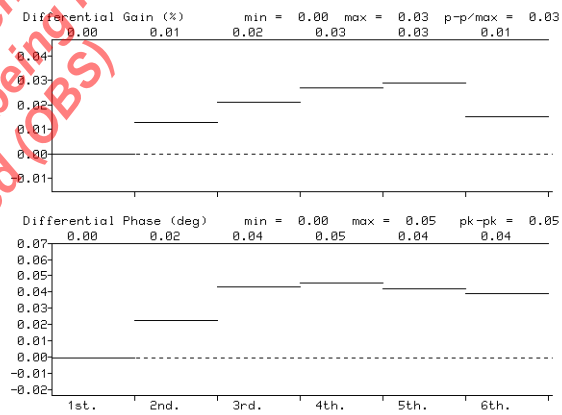

The product (or products) mentioned in this data sheet are no longer being manufactured and may not be ordered (OBS)

Typical Performance Characteristics at ±5V

$T_A = 25^\circ\text{C}$, $V_S = \pm 5\text{V}$, $R_L = 2\text{k}\Omega$ to GND, $G = +2$, $R_F = 1.5\text{k}\Omega$; unless otherwise noted.

Non-Inverting Frequency Response

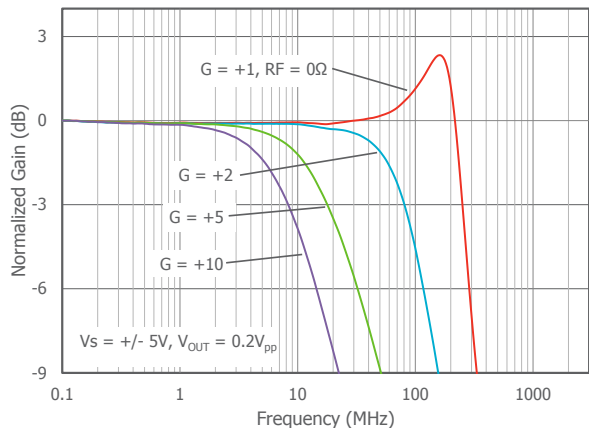

Inverting Frequency Response

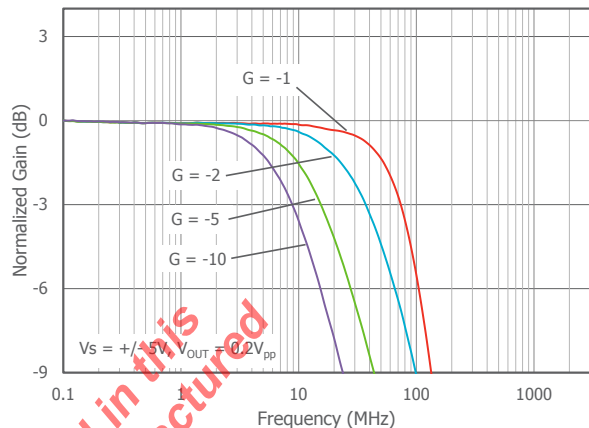

Frequency Response vs C_L

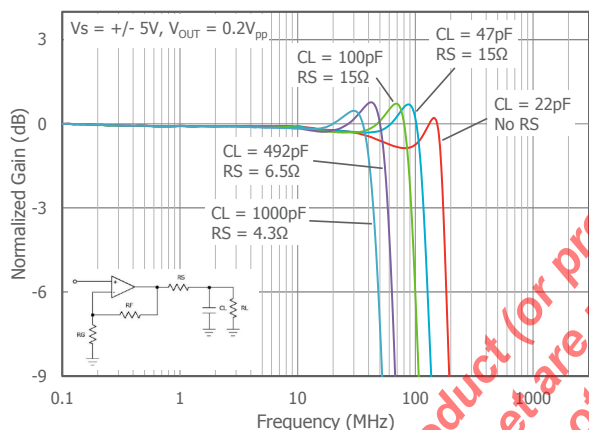

Frequency Response vs R_L

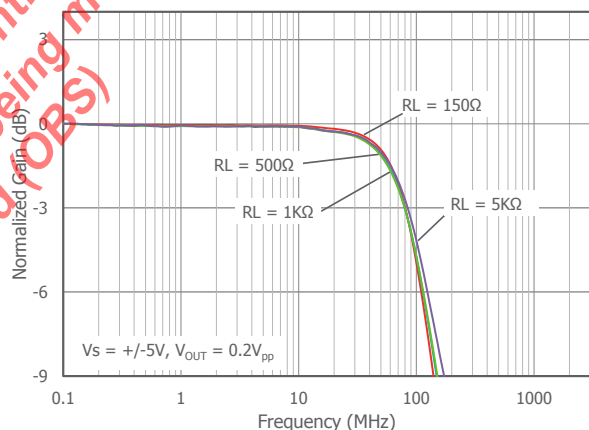

Large Signal Frequency Response

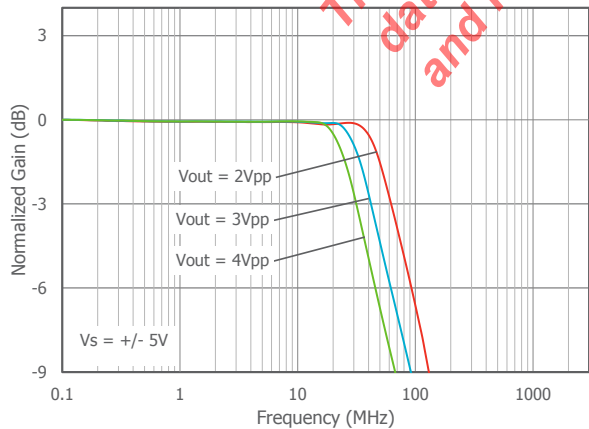

-3dB BW vs Output Voltage

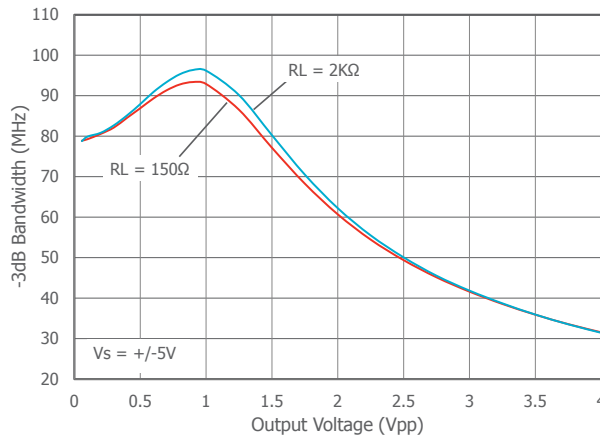

The product (or products) mentioned in this data sheet are no longer being manufactured and may not be ordered (OBS)

Typical Performance Characteristics at $\pm 5V$

$T_A = 25^\circ C$, $V_S = \pm 5V$, $R_L = 2k\Omega$ to GND, $G = +2$, $R_F = 1.5k\Omega$; unless otherwise noted.

Input Voltage Noise vs Frequency

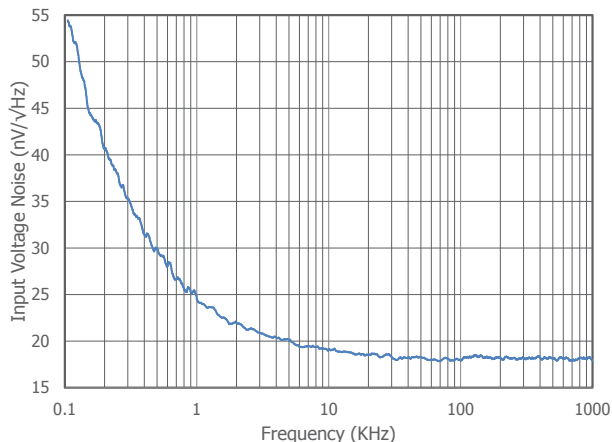

2nd Harmonic Distortion vs R_L over Frequency

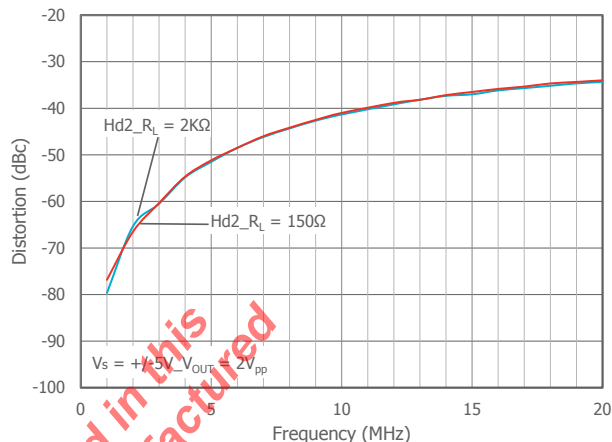

3rd Harmonic Distortion vs R_L over Frequency

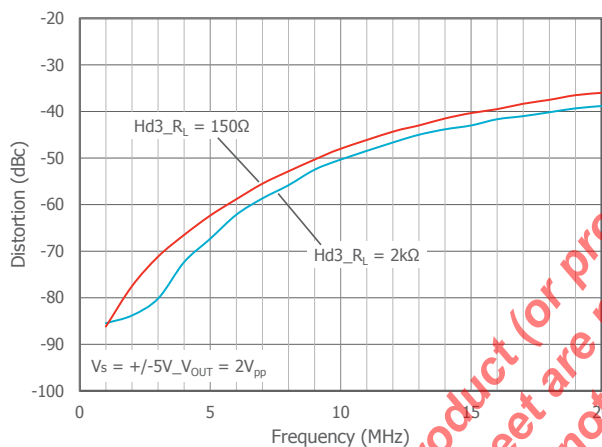

2nd Harmonic Distortion vs V_O over Frequency

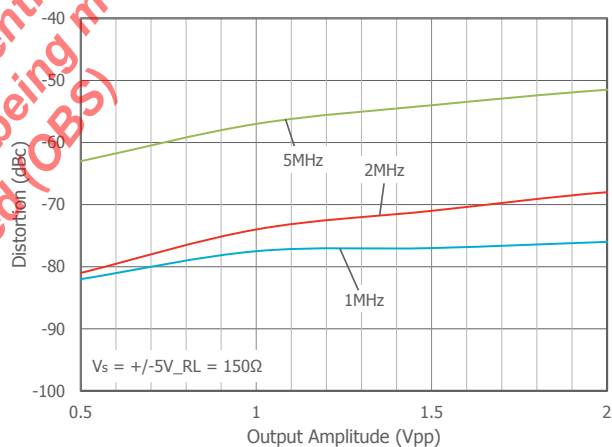

3rd Harmonic Distortion vs V_O over Frequency

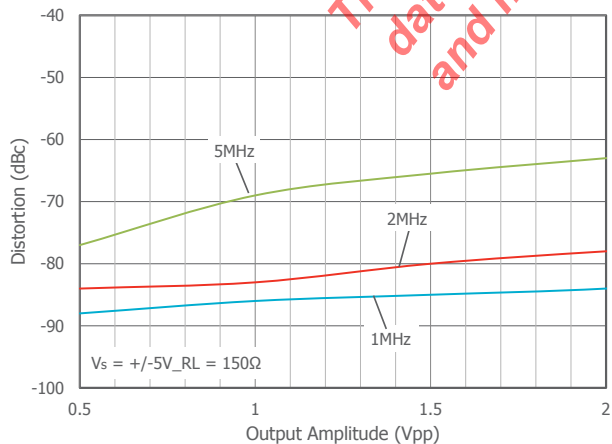

Non-Inverting Small Signal Pulse Response

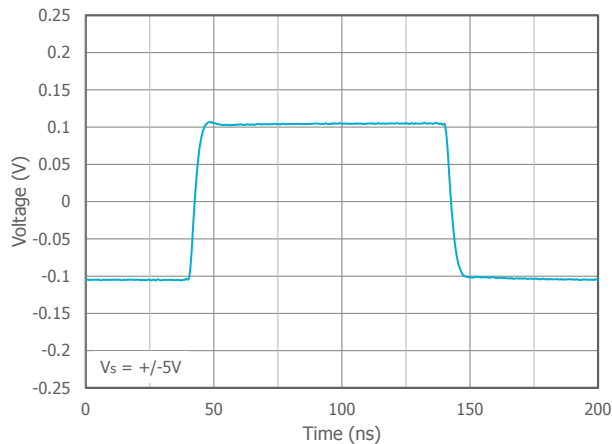

The product (or products) mentioned in this data sheet are no longer being manufactured and may not be ordered (OBS)

Typical Performance Characteristics at ±5V

$T_A = 25^\circ\text{C}$, $V_S = \pm 5\text{V}$, $R_L = 2\text{k}\Omega$ to GND, $G = +2$, $R_F = 1.5\text{k}\Omega$; unless otherwise noted.

Non-Inverting Large Signal Pulse Response

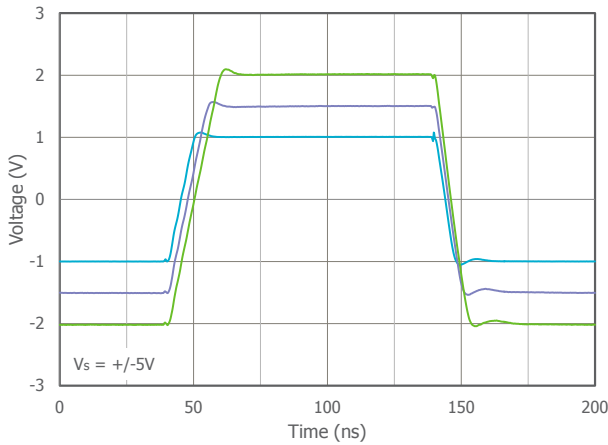

Crosstalk vs Frequency (CLC2007)

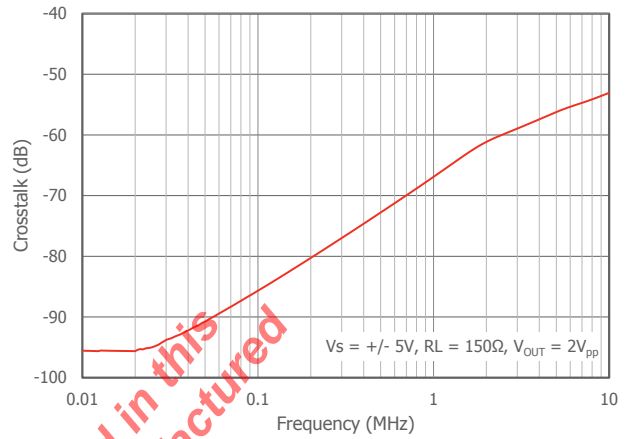

Differential Gain & Phase_DC Coupled

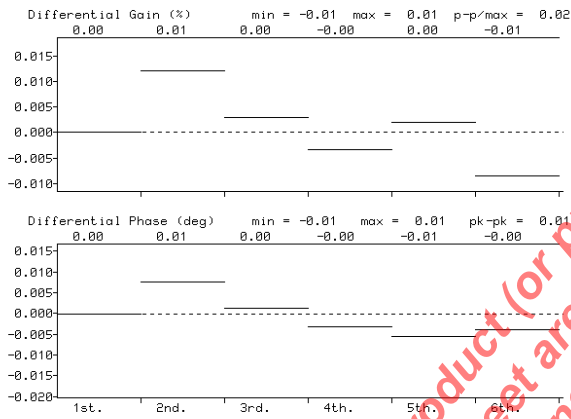

Differential Gain & Phase_AC Coupled

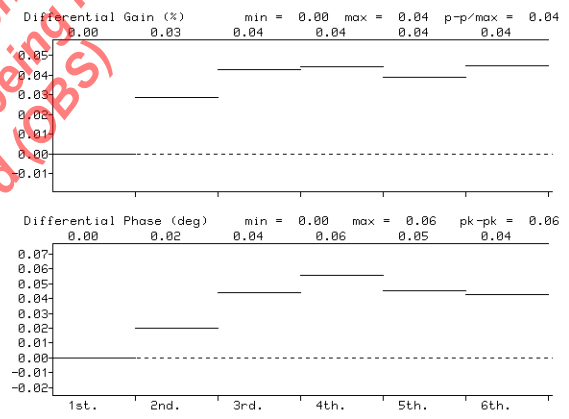

The product (or products) mentioned in this data sheet are no longer being manufactured and may not be ordered (OBS)

Application Information

General Description

The CLC1007, CLC2007, and CLC4007 are single supply, general purpose, voltage-feedback amplifiers fabricated on a complementary bipolar process using a patent pending topography. They feature a rail-to-rail output stage and is unity gain stable. Both gain bandwidth and slew rate are insensitive to temperature.

The common mode input range extends to 300mV below ground and to 0.9V below V_s . Exceeding these values will not cause phase reversal. However, if the input voltage exceeds the rails by more than 0.5V, the input ESD devices will begin to conduct. The output will stay at the rail during this overdrive condition.

The design is short circuit protected and offers “soft” saturation protection that improves recovery time.

Figures 1, 2, and 3 illustrate typical circuit configurations for non-inverting, inverting, and unity gain topologies for dual supply applications. They show the recommended bypass capacitor values and overall closed loop gain equations. Figure 4 shows the typical non-inverting gain circuit for single supply applications.

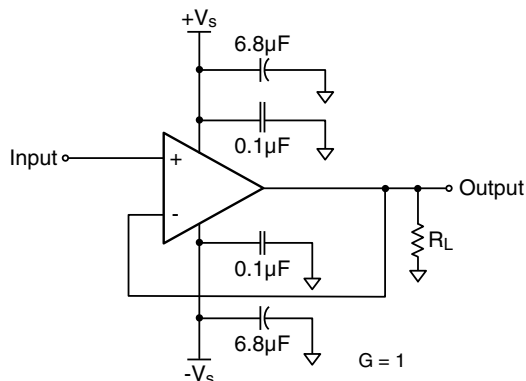

Figure 3: Unity Gain Circuit

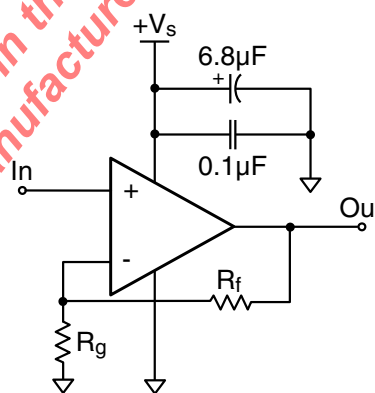

Figure 4: Single Supply Non-Inverting Gain Circuit

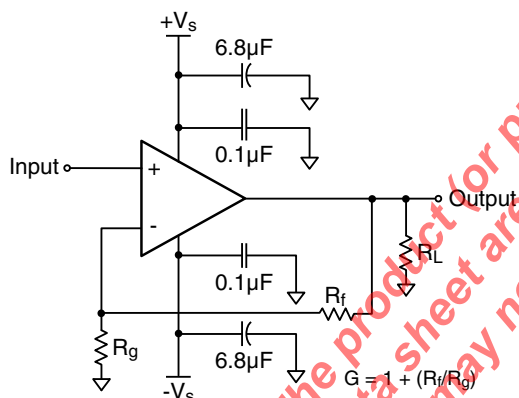

Figure 1: Typical Non-Inverting Gain Circuit

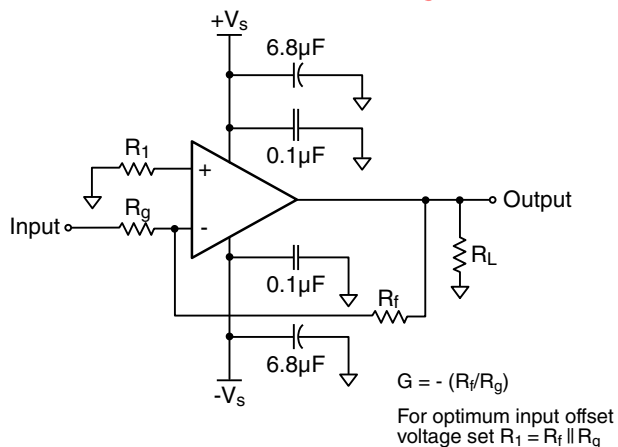

Figure 2: Typical Inverting Gain Circuit

Overdrive Recovery

For an amplifier, an overdrive condition occurs when the output and/or input ranges are exceeded. The recovery time varies based on whether the input or output is overdriven and by how much the ranges are exceeded. The CLC1007, CLC2007, and CLC4007 will typically recover in less than 20ns from an overdrive condition. Figure 5 shows the CLC2007 in an overdriven condition.

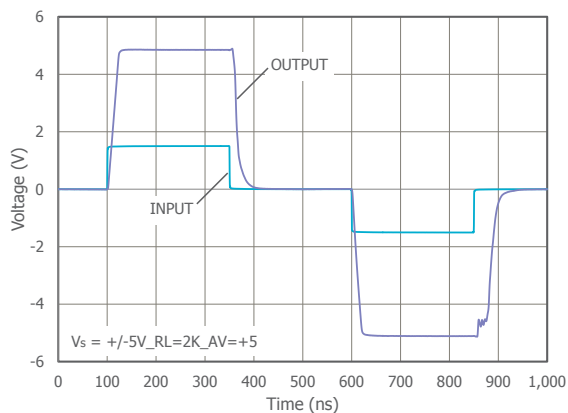

Figure 5: Overdrive Recovery

Power Dissipation

Power dissipation should not be a factor when operating under the stated 2kΩ load condition. However, applications with low impedance, DC coupled loads should be analyzed to ensure that maximum allowed junction temperature is not exceeded. Guidelines listed below can be used to verify that the particular application will not cause the device to operate beyond its intended operating range.

Maximum power levels are set by the absolute maximum junction rating of 170°C. To calculate the junction temperature, the package thermal resistance value θ_{JA} (θ_{JA}) is used along with the total die power dissipation.

$$T_{\text{Junction}} = T_{\text{Ambient}} + (\theta_{JA} \times P_D)$$

Where T_{Ambient} is the temperature of the working environment.

In order to determine P_D , the power dissipated in the load needs to be subtracted from the total power delivered by the supplies.

$$P_D = P_{\text{Supply}} - P_{\text{Load}}$$

Supply power is calculated by the standard power equation.

$$P_{\text{Supply}} = V_{\text{Supply}} \times I_{\text{RMS Supply}}$$

$$V_{\text{Supply}} = V_{S+} - V_{S-}$$

Power delivered to a purely resistive load is:

$$P_{\text{Load}} = ((V_{\text{load}})_{\text{RMS}})^2 / R_{\text{load eff}}$$

The effective load resistor ($R_{\text{load eff}}$) will need to include the effect of the feedback network. For instance,

$R_{\text{load eff}}$ in Figure 3 would be calculated as:

$$R_L \parallel (R_f + R_g)$$

These measurements are basic and are relatively easy to perform with standard lab equipment. For design purposes however, prior knowledge of actual signal levels and load impedance is needed to determine the dissipated power. Here, P_D can be found from

$$P_D = P_{\text{Quiescent}} + P_{\text{Dynamic}} - P_{\text{Load}}$$

Quiescent power can be derived from the specified I_S values along with known supply voltage, V_{Supply} . Load power can be calculated as above with the desired signal amplitudes using:

$$(V_{\text{load}})_{\text{RMS}} = V_{\text{peak}} / \sqrt{2}$$

$$(I_{\text{load}})_{\text{RMS}} = (V_{\text{load}})_{\text{RMS}} / R_{\text{load eff}}$$

The dynamic power is focused primarily within the output stage driving the load. This value can be calculated as:

$$P_{\text{Dynamic}} = (V_{S+} - V_{\text{load}})_{\text{RMS}} \times (I_{\text{load}})_{\text{RMS}}$$

Assuming the load is referenced in the middle of the power rails or $V_{\text{Supply}}/2$.

The CLC1007 is short circuit protected. However, this may not guarantee that the maximum junction temperature (+150°C) is not exceeded under all conditions. Figure 6 shows the maximum safe power dissipation in the package vs. the ambient temperature for the packages available.

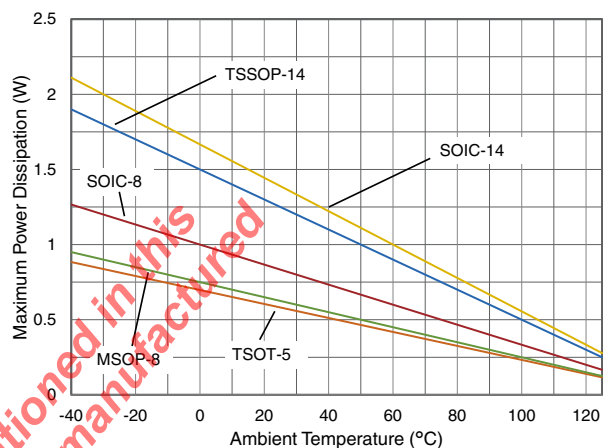

Figure 6. Maximum Power Derating

Driving Capacitive Loads

Increased phase delay at the output due to capacitive loading can cause ringing, peaking in the frequency response, and possible unstable behavior. Use a series resistance, R_S , between the amplifier and the load to help improve stability and settling performance. Refer to Figure 7.

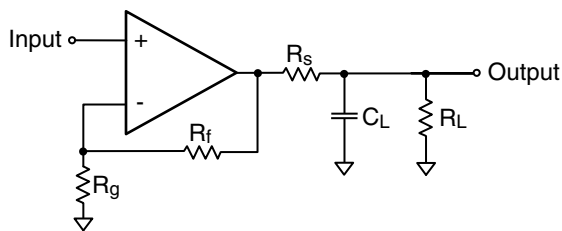

Figure 7. Addition of R_S for Driving Capacitive Loads

Table 1 provides the recommended R_S for various capacitive loads. The recommended R_S values result in approximately <1dB peaking in the frequency response.

C_L (pF)	R_S (Ω)	-3dB BW (MHz)
22pF	0	118
47pF	15	112
100pF	15	91
492pF	6.5	59

Table 1: Recommended R_S vs. C_L

For a given load capacitance, adjust R_S to optimize the tradeoff between settling time and bandwidth. In general, reducing R_S will increase bandwidth at the expense of additional overshoot and ringing.

Layout Considerations

General layout and supply bypassing play major roles in high frequency performance. Exar has evaluation boards to use as a guide for high frequency layout and as an aid in device testing and characterization. Follow the steps below as a basis for high frequency layout:

- Include 6.8 μ F and 0.1 μ F ceramic capacitors for power supply decoupling
- Place the 6.8 μ F capacitor within 0.75 inches of the power pin
- Place the 0.1 μ F capacitor within 0.1 inches of the power pin
- Remove the ground plane under and around the part, especially near the input and output pins to reduce parasitic capacitance
- Minimize all trace lengths to reduce series inductances

Refer to the evaluation board layouts below for more information.

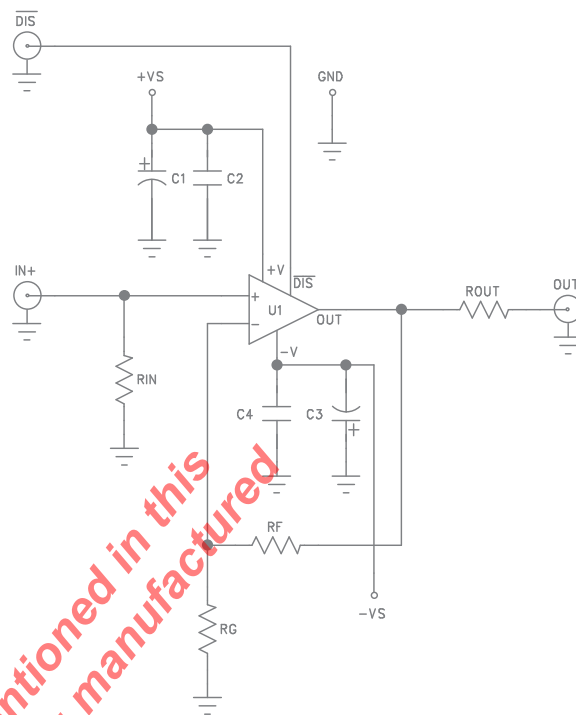

Figure 8. CEB002 & CEB003 Schematic

Evaluation Board Information

The following evaluation boards are available to aid in the testing and layout of these devices:

Evaluation Board #	Products
CEB002	CLC1007 in TSOT
CEB003	CLC1007 in SOIC
CEB006	CLC2007 in SOIC
CEB010	CLC2007 in MSOP
CEB018	CLC4007 in SOIC
CEB019	CLC4007 in TSSOP

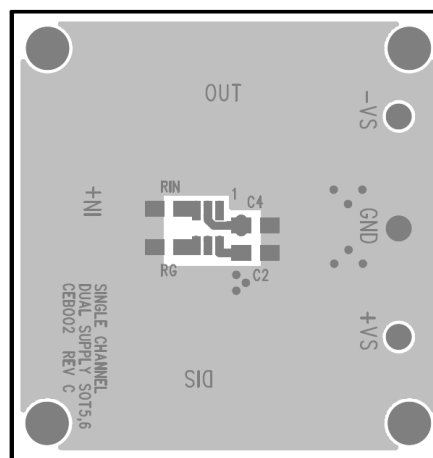

Figure 9. CEB002 Top View

Evaluation Board Schematics

Evaluation board schematics and layouts are shown in Figures 8-20. These evaluation boards are built for dual-supply operation. Follow these steps to use the board in a single-supply application:

1. Short $-V_S$ to ground.
2. Use C3 and C4, if the $-V_S$ pin of the amplifier is not directly connected to the ground plane.

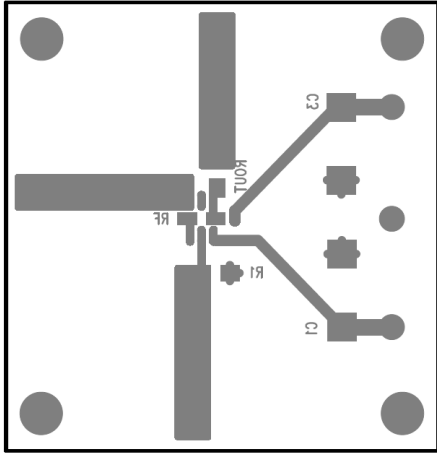

Figure 10. CEB002 Bottom View

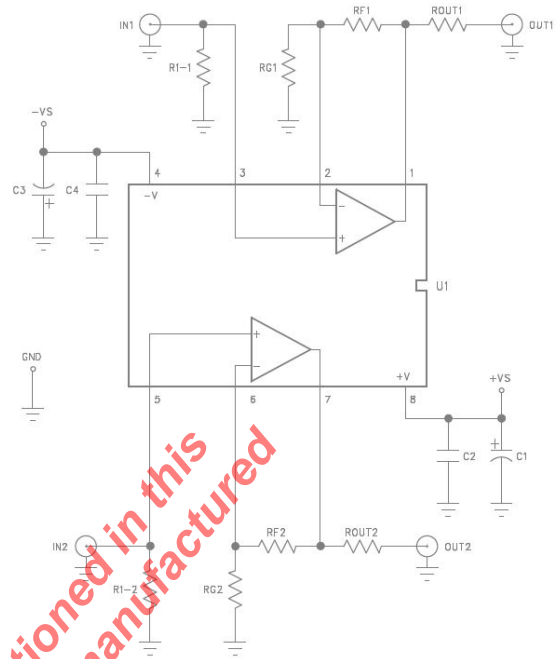

Figure 13. CEB006 & CEB010 Schematic

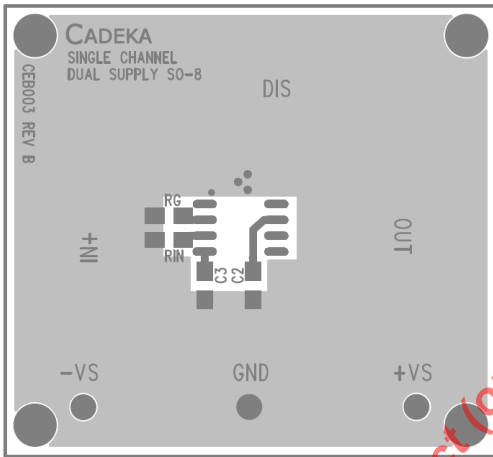

Figure 11. CEB003 Top View

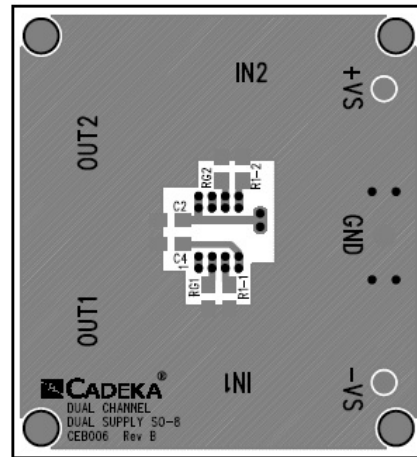

Figure 14. CEB006 Top View

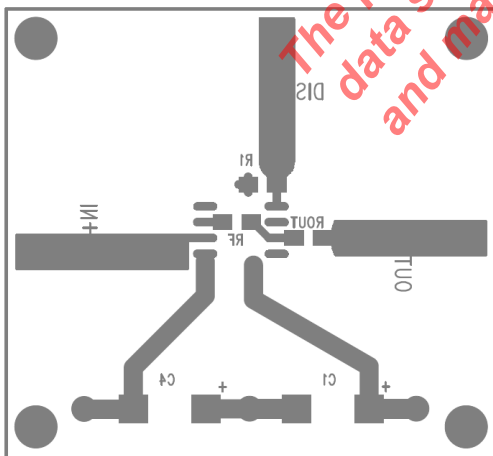

Figure 12. CEB003 Bottom View

The product (or products) mentioned in this data sheet are no longer being manufactured and may not be ordered (OBS)

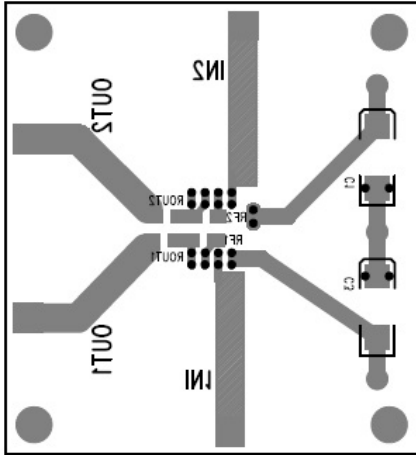

Figure 15. CEB006 Bottom View

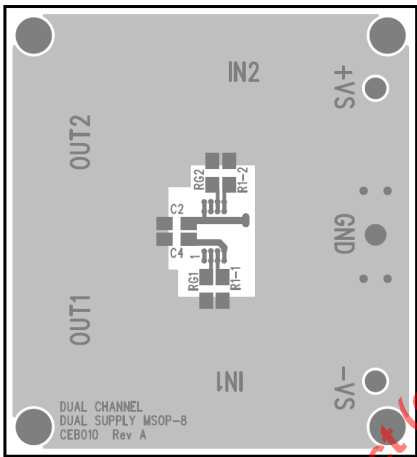

Figure 16. CEB010 Top View

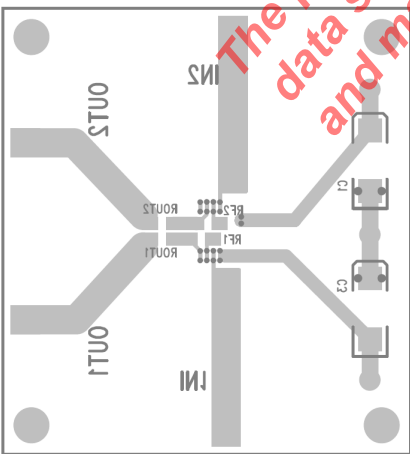

Figure 17. CEB010 Bottom View

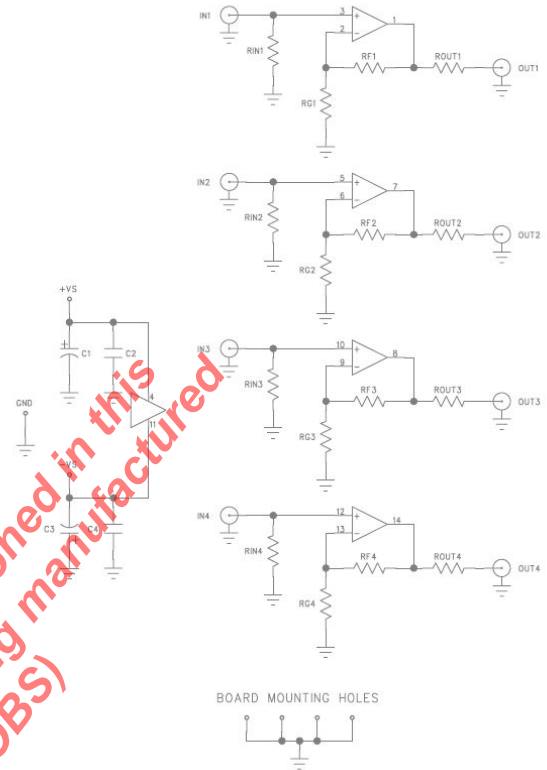

Figure 18. CEB018 Schematic

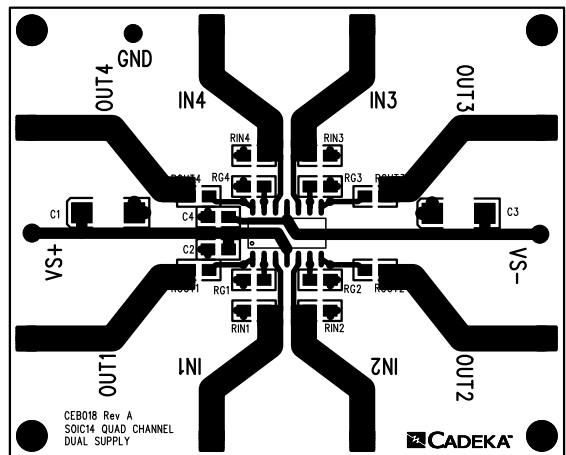

Figure 19. CEB018 Top View

The product (or products) mentioned in this data sheet are no longer being manufactured and may not be ordered (OBS)

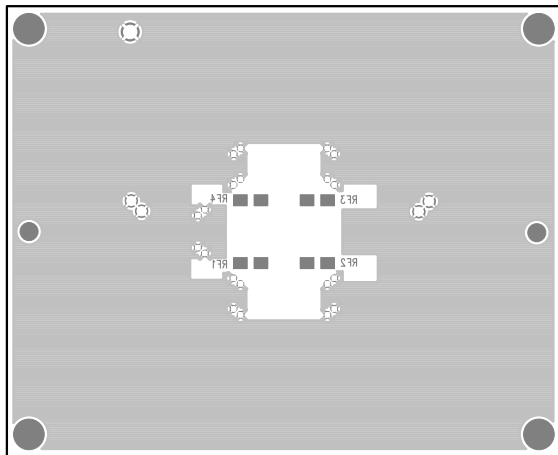
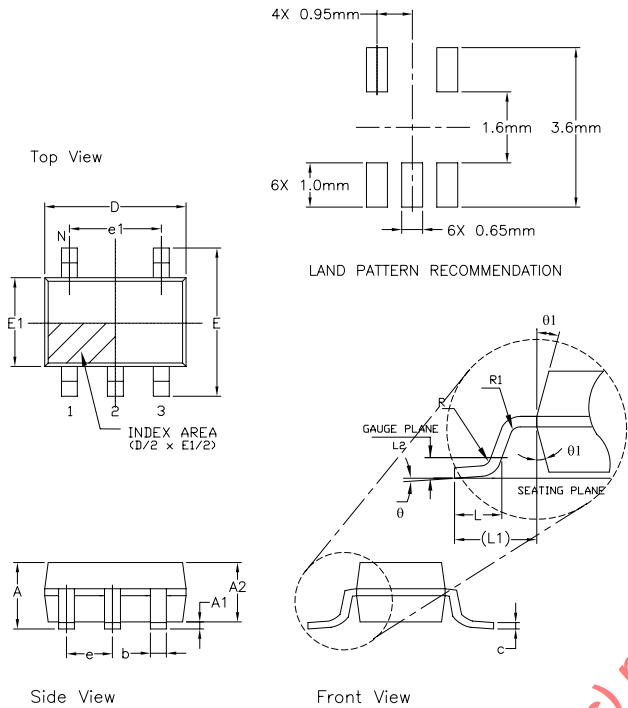

Figure 20. CEB018 Bottom View

The product (or products) mentioned in this data sheet are no longer being manufactured and may not be ordered (OBS)

Mechanical Dimensions

TSOT-5 Package



5 Pin TSOT (OPTION 2)						
SYMBOLS	DIMENSION IN MM (Control Unit)			DIMENSION IN INCH (Reference Unit)		
	MIN	NOM	MAX	MIN	NOM	MAX
A	0.75	—	0.80	0.030	—	0.031
A1	0.00	—	0.05	0.000	—	0.002
A2	0.70	0.75	0.78	0.028	0.030	0.031
b	0.35	—	0.50	0.012	—	0.020
c	0.10	—	0.20	0.003	—	0.008
D	2.90 BSC			0.114 BSC		
E	2.80 BSC			0.110 BSC		
E1	1.60 BSC			0.063 BSC		
e	0.95 BSC			0.038 BSC		
e1	1.90 BSC			0.075 BSC		
L	0.37	0.45	0.60	0.012	0.018	0.024
L1	0.60 REF			0.024 REF		
L2	0.25 BSC			0.010 BSC		
R	0.10	—	—	0.004	—	—
R1	0.10	—	0.25	0.004	—	0.010
θ	0°	4°	8°	0°	4°	8°
θ1	4°	10°	12°	4°	10°	12°
N	5			5		

MSOP-8 Package

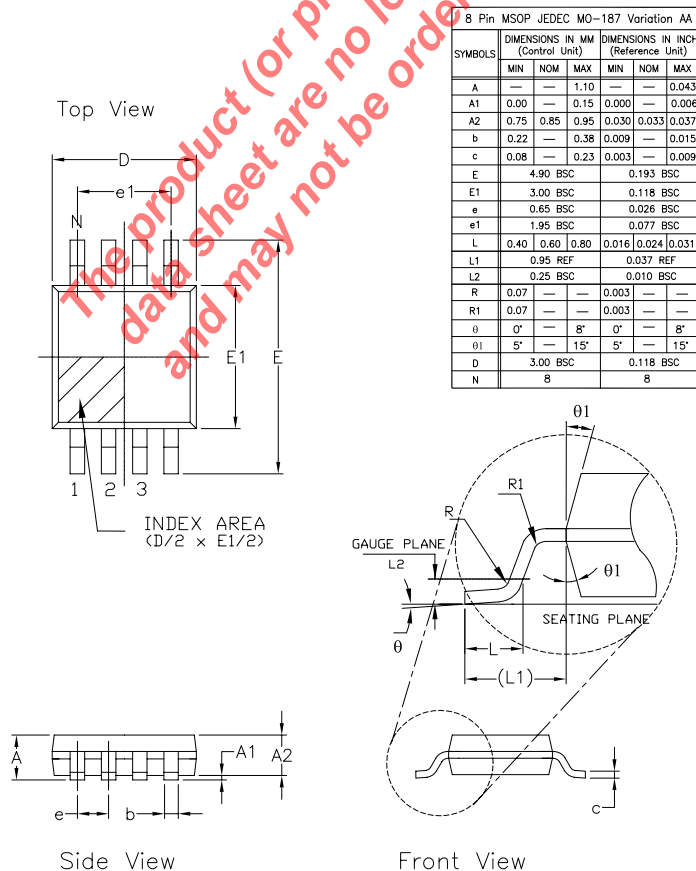

SOIC-8 Package

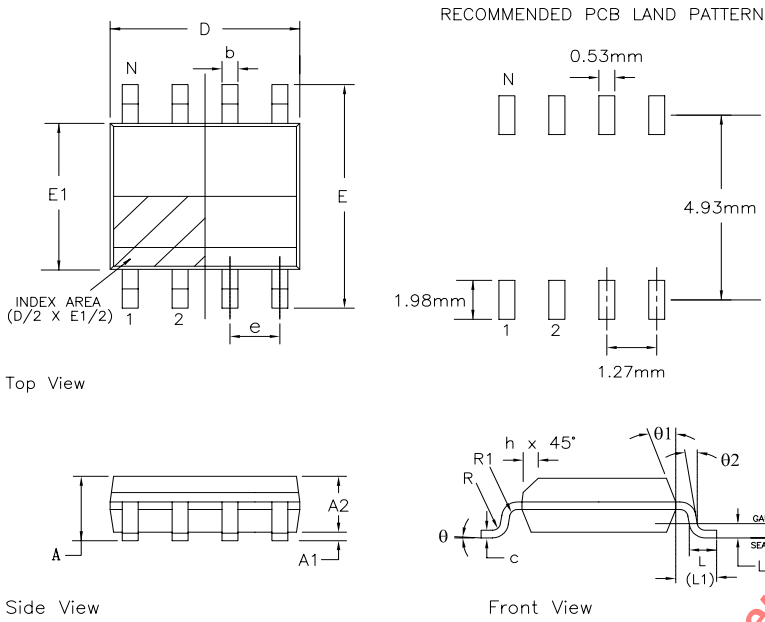

8 Pin SOICN JEDEC MS-012 Variation AA						
SYMBOLS	DIMENSIONS IN MM (Control Unit)			DIMENSIONS IN INCH (Reference Unit)		
	MIN	NOM	MAX	MIN	NOM	MAX
A	1.35	—	1.75	0.053	—	0.069
A1	0.10	—	0.25	0.004	—	0.010
A2	1.25	—	1.65	0.049	—	0.065
b	0.31	—	0.51	0.012	—	0.020
c	0.17	—	0.25	0.007	—	0.010
E	6.00 BSC			0.236 BSC		
E1	3.90 BSC			0.154 BSC		
e	1.27 BSC			0.050 BSC		
h	0.25	—	0.50	0.010	—	0.020
L	0.40	—	1.27	0.016	—	0.050
L1	1.04 REF			0.041 REF		
L2	0.25 BSC			0.010 BSC		
R	0.07	—	—	0.003	—	—
R1	0.07	—	—	0.003	—	—
θ	0°	—	8°	0°	—	8°
01	5°	—	15°	5°	—	15°
02	0°	—	—	0°	—	—
D	4.90 BSC			0.193 BSC		
N	8			8		

SOIC-14 Package

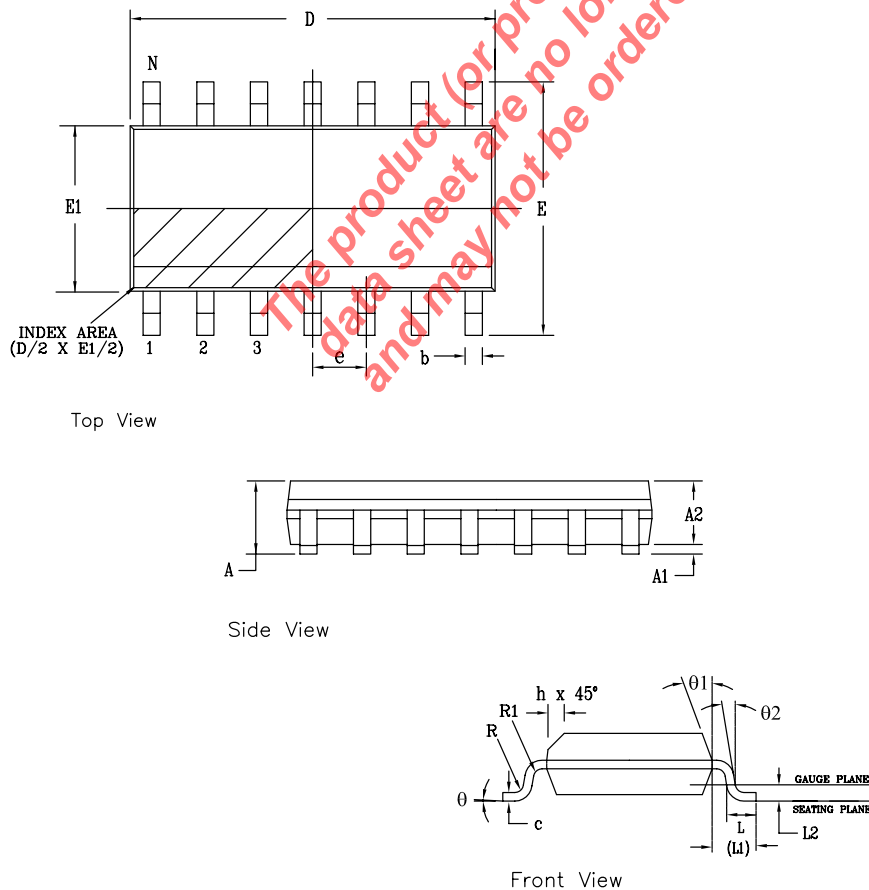

PACKAGE OUTLINE NSOIC .150" BODY JEDEC MS-012						
SYMBOLS	COMMON DIMENSIONS IN MM (Control Unit)			COMMON DIMENSIONS IN INCH (Reference Unit)		
	MIN	NOM	MAX	MIN	NOM	MAX
A	1.35	—	1.75	0.053	—	0.069
A1	0.10	—	0.25	0.004	—	0.010
A2	1.25	—	1.65	0.049	—	0.065
b	0.31	—	0.51	0.012	—	0.020
c	0.17	—	0.25	0.007	—	0.010
E	6.00 BSC			0.236 BSC		
E1	3.90 BSC			0.154 BSC		
e	1.27 BSC			0.050 BSC		
h	0.25	—	0.50	0.010	—	0.020
L	0.40	—	1.27	0.016	—	0.050
L1	1.04 REF			0.041 REF		
L2	0.25 BSC			0.010 BSC		
R	0.07	—	—	0.003	—	—
R1	0.07	—	—	0.003	—	—
θ	0°	—	8°	0°	—	8°
01	5°	—	15°	5°	—	15°
02	0°	—	—	0°	—	—
D	SEE VARIATIONS					
N	SEE VARIATIONS					

VARIATION D						
VARIATION	DIMENSIONS IN MM (Control Unit)			DIMENSIONS IN INCH (Reference Unit)		
	MIN	NOM	MAX	MIN	NOM	MAX
AA	4.90	BSC	—	0.193	BSC	8
AB	8.65	BSC	—	0.341	BSC	14
AC	9.90	BSC	—	0.390	BSC	16

TSSOP-14 Package

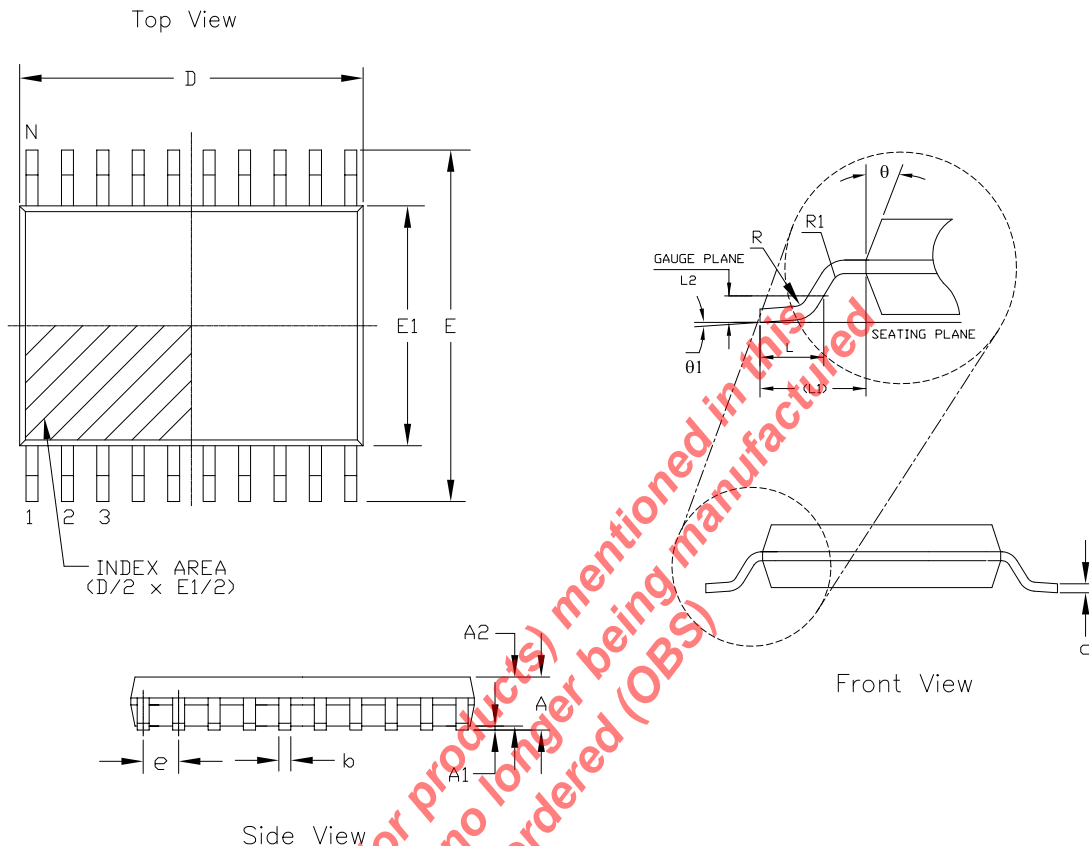

The product (or products) mentioned in this data sheet are no longer being manufactured and may not be ordered (OBS)

14 Pin TSSOP JEDEC MO-153 Variation AB-1						
SYMBOLS	DIMENSIONS IN MM (Control Unit)			DIMENSIONS IN INCH (Reference Unit)		
	MIN	NOM	MAX	MIN	NOM	MAX
A	—	—	1.20	—	—	0.047
A1	0.05	—	0.15	0.002	—	0.006
A2	0.80	1.00	1.05	0.031	0.039	0.041
b	0.19	—	0.30	0.007	—	0.012
c	0.09	—	0.20	0.004	—	0.008
E	6.40 BSC			0.252 BSC		
E1	4.30	4.40	4.50	0.169	0.173	0.177
e	0.65 BSC			0.026 BSC		
L	0.45	0.60	0.75	0.018	0.024	0.030
L1	1.00 REF			0.039 REF		
L2	0.25 BSC			0.010 BSC		
R	0.09	—	—	0.035	—	—
R1	0.09	—	—	0.035	—	—
θ	12° REF			12° REF		
$\theta 1$	0°	—	8°	0°	—	8°
D	4.90	5.00	5.10	0.193	0.197	0.200
N	14			14		

Ordering Information

Part Number	Package	Green	Operating Temperature Range	Packaging
CLC1007 Ordering Information				
CLC1007IST5X	TSOT-5	Yes	-40°C to +125°C	Tape & Reel
CLC1007IST5MTR	TSOT-5	Yes	-40°C to +125°C	Mini Tape & Reel
CLC1007IST5EVB	Evaluation Board	N/A	N/A	N/A
CLC1007ISO8X	SOIC-8	Yes	-40°C to +125°C	Tape & Reel
CLC1007ISO8MTR	SOIC-8	Yes	-40°C to +125°C	Mini Tape & Reel
CLC1007ISO8EVB	Evaluation Board	N/A	N/A	N/A
CLC2007 Ordering Information				
CLC2007ISO8X	SOIC-8	Yes	-40°C to +125°C	Tape & Reel
CLC2007ISO8MTR	SOIC-8	Yes	-40°C to +125°C	Mini Tape & Reel
CLC2007ISO8EVB	Evaluation Board	N/A	N/A	N/A
CLC2007IMP8X	MSOP-8	Yes	-40°C to +125°C	Tape & Reel
CLC2007IMP8MTR	MSOP-8	Yes	-40°C to +125°C	Mini Tape & Reel
CLC2007IMP8EVB	Evaluation Board	N/A	N/A	N/A
CLC4007 Ordering Information				
CLC4007ITP14X	TSSOP-14	Yes	-40°C to +125°C	Tape & Reel
CLC4007ITP14MTR	TSSOP-14	Yes	-40°C to +125°C	Mini Tape & Reel
CLC4007ITP14EVB	Evaluation Board	N/A	N/A	N/A
CLC4007ISO14X	SOIC-14	Yes	-40°C to +125°C	Tape & Reel
CLC4007ISO14MTR	SOIC-14	Yes	-40°C to +125°C	Mini Tape & Reel
CLC4007ISO14EVB	Evaluation Board	N/A	N/A	N/A

Moisture sensitivity level for all parts is MSL-1.

The product (or products) mentioned in this data sheet are no longer being manufactured and may not be ordered (OBSOLETE)

Revision History

Revision	Date	Description
1D (ECN 1451-07)	December 2014	Reformat into Exar data sheet template. Updated ordering information table to include MTR and EVB part numbers. Increased "I" temperature range from +85 to +125°C. Removed "A" temp grade parts, since "I" is now equivalent. Updated thermal resistance numbers and package outline drawings.

The product (or products) mentioned in this data sheet are no longer being manufactured and may not be ordered (OBS)

For Further Assistance:

Email: CustomerSupport@exar.com or HPATechSupport@exar.com

Exar Technical Documentation: <http://www.exar.com/techdoc/>

Exar Corporation Headquarters and Sales Offices

48760 Kato Road
Fremont, CA 94538 - USA

Tel.: +1 (510) 668-7000
Fax: +1 (510) 668-7001



A New Direction in Mixed-Signal

NOTICE

EXAR Corporation reserves the right to make changes to the products contained in this publication in order to improve design, performance or reliability. EXAR Corporation assumes no responsibility for the use of any circuits described herein, conveys no license under any patent or other right, and makes no representation that the circuits are free of patent infringement. Charts and schedules contained here in are only for illustration purposes and may vary depending upon a user's specific application. While the information in this publication has been carefully checked; no responsibility, however, is assumed for inaccuracies.

EXAR Corporation does not recommend the use of any of its products in life support applications where the failure or malfunction of the product can reasonably be expected to cause failure of the life support system or to significantly affect its safety or effectiveness. Products are not authorized for use in such applications unless EXAR Corporation receives, in writing, assurances to its satisfaction that: (a) the risk of injury or damage has been minimized; (b) the user assumes all such risks; (c) potential liability of EXAR Corporation is adequately protected under the circumstances.

Reproduction, in part or whole, without the prior written consent of EXAR Corporation is prohibited.